

INSTRUCTION MANUAL

P2006078 REV B



hydrovar[®] X Smart Pump Range

Integrated pump, motor & variable speed drive solutions
powered by hydrovar X



Table of Contents

1	Introduction and Safety.....	3
1.1	Introduction.....	3
1.2	Safety.....	3
1.2.1	Safety message levels.....	3
1.2.2	User safety.....	4
1.2.3	Wash the skin and eyes.....	5
1.3	Protecting the environment.....	5
2	Transportation and Storage.....	7
2.1	Examine the delivery.....	7
2.1.1	Examine the package.....	7
2.1.2	Examine the unit.....	7
2.2	Unit handling.....	7
2.3	Storage guidelines.....	8
3	Product Description.....	9
3.1	General description.....	9
3.2	Intended applications.....	9
3.2.1	Control modes.....	9
3.3	Data plates.....	10
3.3.1	hydrovar X nameplates.....	10
3.4	hydrovar X design layout.....	11
4	Installation.....	14
4.1	Mechanical installation.....	14
4.1.1	Installation area.....	14
4.1.2	Unit installation.....	14
4.2	Hydraulic installation.....	15
4.3	Electrical installation.....	17
4.3.1	Precautions.....	17
4.3.2	Electrical connection guidelines.....	18
4.3.3	Control panel guidelines.....	18
4.3.4	Fuses and/or circuit breakers.....	18
4.3.5	Residual current devices, RCD (GFCI).....	19
4.4	Drive guidelines.....	20
4.4.1	Drive assembly.....	20
4.4.2	Power supply connection.....	20
4.4.3	Power cable installation.....	21
4.4.4	Auxiliary connections.....	21
5	Operation.....	24
5.1	Precautions.....	24
5.2	Wait times.....	24
6	System Setup and Operation.....	25
6.1	Programming precautions.....	25
6.2	hydrovar X drive display and controls.....	25
6.3	Graphic display.....	26
6.3.1	hydrovar X parameter menu.....	27
6.3.2	Start the unit.....	27

6.3.3 Operating mode change for hydrovar X.....	28
6.3.4 Error reset for hydrovar X.....	28
6.4 Xylem X App.....	28
7 Technical Specification.....	30
7.1 Operating environment.....	30
7.2 Electrical specifications.....	30
7.3 Compliance of radio frequency characteristics.....	30
7.4 Characteristics of inputs and outputs.....	31
7.5 Dimensions and weights.....	32
8 Cybersecurity.....	34
8.1 Xylem product cybersecurity.....	34
8.2 Security recommendations for end-user.....	34
9 Product Warranty.....	37

1 Introduction and Safety

1.1 Introduction

Purpose of this manual

The purpose of this manual is to provide necessary information for:

- Installation
- Operation
- Maintenance



CAUTION:

Read this manual carefully before installing and using the product. Improper use of the product can cause personal injury and damage to property, and may void the warranty.

NOTICE:

Save this manual for future reference, and keep it readily available at the location of the unit.

1.2 Safety



WARNING:

- The operator must be aware of safety precautions to prevent physical injury.
- Operating, installing, or maintaining the unit in any way that is not covered in this manual could cause death, serious personal injury, or damage to the equipment. This includes any modification to the equipment or use of parts not provided by Xylem. If there is a question regarding the intended use of the equipment, please contact a Xylem representative before proceeding.
- Do not change the service application without the approval of an authorized Xylem representative.



CAUTION:

You must observe the instructions contained in this manual. Failure to do so could result in physical injury, damage, or death.

1.2.1 Safety message levels



About safety messages

It is extremely important that you read, understand, and follow the safety messages and regulations carefully before handling the product. They are published to help prevent these hazards:

- Personal accidents and health problems
- Damage to the product
- Product malfunction

Definitions

Safety message level	Indication
 DANGER:	A hazardous situation which, if not avoided, will result in death or serious injury

Safety message level	Indication
 WARNING:	A hazardous situation which, if not avoided, could result in death or serious injury
 CAUTION:	A hazardous situation which, if not avoided, could result in minor or moderate injury
 Electrical Hazard:	The possibility of electrical risks if instructions are not followed in a proper manner
NOTICE:	<ul style="list-style-type: none"> • A potential situation which, if not avoided, could result in undesirable conditions • A practice not related to personal injury

1.2.2 User safety

General safety rules

These safety rules apply:

- Always keep the work area clean.
- Pay attention to the risks presented by gas and vapors in the work area.
- Avoid all electrical dangers. Pay attention to the risks of electric shock or arc flash hazards.
- Always bear in mind the risk of drowning, electrical accidents, and burn injuries.

Safety equipment

Use safety equipment according to the company regulations. Use this safety equipment within the work area:

- Hard hat
- Safety goggles, preferably with side shields
- Protective shoes
- Protective gloves
- Gas mask
- Hearing protection
- First-aid kit
- Safety devices

NOTICE:

Never operate a unit unless safety devices are installed. Also see specific information about safety devices in other chapters of this manual.

Electrical connections

Electrical connections must be made by certified electricians in compliance with all international, national, state, and local regulations. For more information about requirements, see sections dealing specifically with electrical connections.

Precautions before work

Observe these safety precautions before you work with the product or are in connection with the product:

- Provide a suitable barrier around the work area, for example, a guard rail.
- Make sure that all safety guards are in place and secure.

- Make sure that you have a clear path of retreat.
- Make sure that the product cannot roll or fall over and injure people or damage property.
- Make sure that the lifting equipment is in good condition.
- Use a lifting harness, a safety line, and a breathing device as required.
- Allow all system and pump components to cool before you handle them.
- Make sure that the product has been thoroughly cleaned.
- Disconnect and lock out power before you service the pump.
- Check the explosion risk before you weld or use electric hand tools.

Precautions during work

Observe these safety precautions when you work with the product or are in connection with the product:

- Never work alone.
- Always wear protective clothing and hand protection.
- Stay clear of suspended loads.
- Always lift the product by its lifting device.
- Beware of the risk of a sudden start if the product is used with an automatic level control.
- Beware of the starting jerk, which can be powerful.
- Rinse the components in water after you disassemble the pump.
- Do not exceed the maximum working pressure of the pump.
- Do not open any vent or drain valve or remove any plugs while the system is pressurized. Make sure that the pump is isolated from the system and that pressure is relieved before you disassemble the pump, remove plugs, or disconnect piping.
- Never operate a pump without a properly installed coupling guard.

1.2.3 Wash the skin and eyes

Follow these procedures for chemicals or hazardous fluids that have come into contact with your eyes or your skin:

Condition	Action
Chemicals or hazardous fluids in eyes	<ol style="list-style-type: none"> 1. Hold your eyelids apart forcibly with your fingers. 2. Rinse the eyes with eyewash or running water for at least 15 minutes. 3. Seek medical attention.
Chemicals or hazardous fluids on skin	<ol style="list-style-type: none"> 1. Remove contaminated clothing. 2. Wash the skin with soap and water for at least 1 minute. 3. Seek medical attention, if necessary.

1.3 Protecting the environment

Emissions and waste disposal

Observe the local regulations and codes regarding:

- Reporting of emissions to the appropriate authorities
- Sorting, recycling and disposal of solid or liquid waste
- Clean-up of spills

Exceptional sites



CAUTION: Radiation Hazard

Do NOT send the product to Xylem if it has been exposed to nuclear radiation, unless Xylem has been informed and appropriate actions have been agreed upon.

Recycling guidelines

Always follow local laws and regulations regarding recycling.

Waste and emissions guidelines

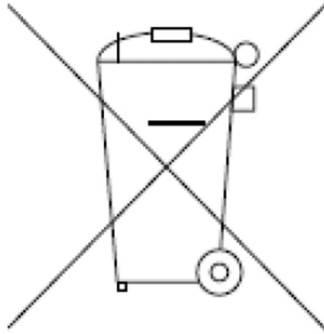

Do not dispose of equipment containing electrical components together with domestic waste.
Collect it separately in accordance with local and currently valid legislation.

EN

2 Transportation and Storage

2.1 Examine the delivery

EN

2.1.1 Examine the package

1. Examine the package for damaged or missing items upon delivery.
2. Record any damaged or missing items on the receipt and freight bill.
3. If anything is out of order, then file a claim with the shipping company.
If the product has been picked up at a distributor, make a claim directly to the distributor.

2.1.2 Examine the unit

1. Remove packing materials from the product.
Dispose of all packing materials in accordance with local regulations.
2. To determine whether any parts have been damaged or are missing, examine the product.
3. If applicable, unfasten the product by removing any screws, bolts, or straps.
Use care around nails and straps.
4. If there is any issue, then contact a sales representative.

2.2 Unit handling



WARNING:

Assembled units and their components are heavy. Failure to properly lift and support this equipment can result in serious physical injury and/or equipment damage. Lift equipment only at the specifically identified lifting points. Lifting devices such as eyebolts, slings, and spreaders must be rated, selected, and used for the entire load being lifted.



WARNING: Crush Hazard

Always lift the unit by its designated lifting points.
Use suitable lifting equipment and ensure that the product is properly harnessed.
Wear personal protective equipment.
Stay clear of cables and suspended loads.

hydrovar X Smart Motor Product Line

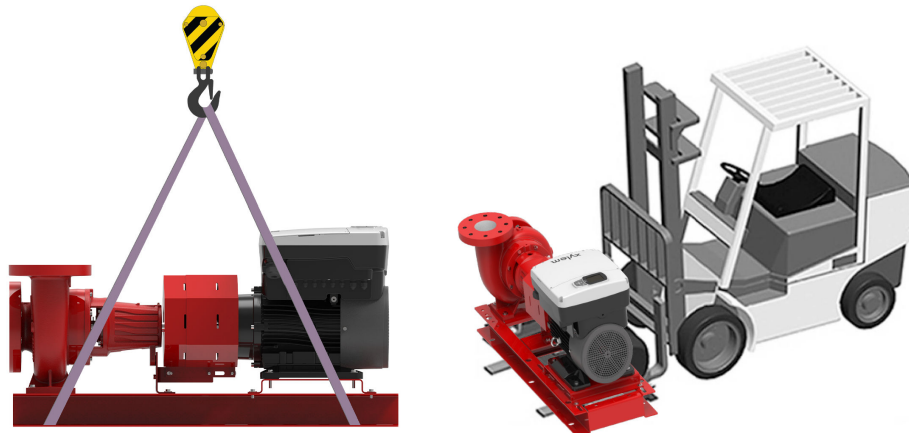

Acceptable lifting methods for base-mounted models e-1510X and e-1532X

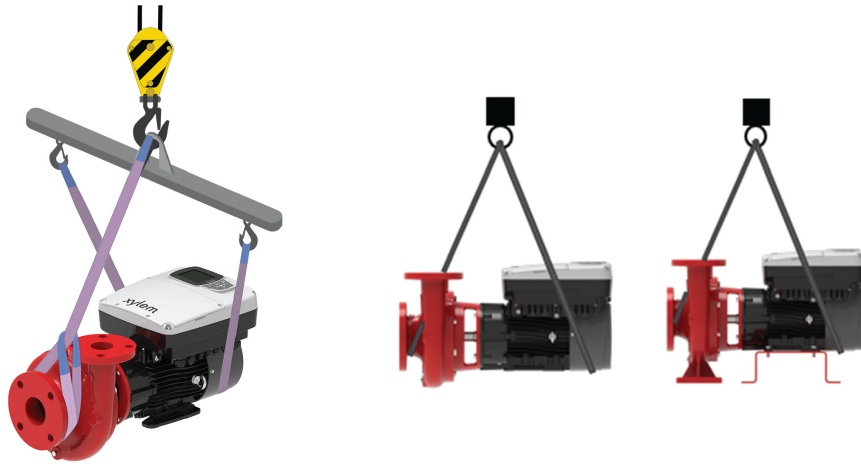

Acceptable lifting methods for close-coupled end-suction models e-1531X and e-1532X



Acceptable lifting methods for in-line models e-80X

NOTICE:

When lifting e-80X models, it is recommended to attach additional safety ropes to the motor eyelets to maintain balance. Alternatively, the ropes wrapped around the unit may be passed through the motor eyelets as demonstrated in the right-hand figure of acceptable lifting methods for the e-80X. If using secondary ropes attached to the eyelets, ensure the ropes are slacked.

2.3 Storage guidelines

Storage location

The product must be stored in a covered and dry location free from heat, dirt, and vibrations.

NOTICE:

Protect the product against humidity, heat sources, and mechanical damage.

NOTICE:

Do not place heavy weights on the packed product.

Store this product at an ambient temperature between -40F (-40C) and +158F (+70C) with a max relative humidity of 90% at +86F (+30C).

3 Product Description

3.1 General description

This product is a variable speed pump unit equipped with the hydrovar X smart motor. The unit may be installed vertically or horizontally in accordance with the acceptable installation configurations of the individual pump products listed in this document. The unit is non self-priming.

EN

3.2 Intended applications



WARNING: Chemical Hazard

This product can expose you to Mercury. Mercury is known to the State of California to cause cancer and birth defects or other reproductive harm. For more information go to: www.P65Warnings.ca.gov.

The pump is intended for use with these pumped fluids:

- Unheated domestic and fresh water
- Boiler feed water
- Condensate
- Hydronic cooling or heating
- Benign liquids
- Pressure boosting
- General liquid transfer

3.2.1 Control modes

Actuator	The unit works as a constant-speed actuator, varying the motor speed according to an external speed signal or to one or more programmed speeds. Actuator mode can only be used for one unit in single operation.
Constant Pressure	The unit maintains constant pressure regardless of flow variation. The pressure feedback is read through a sensor connected to an analog input or through fieldbus.
Proportional Pressure	The unit increased the pressure setpoint (actual required value) in a linear manner in proportion to the flow. The flow can be approximated using the motor speed or measured using a flow sensor connected to an analog input or through fieldbus. The pressure feedback is read through a sensor connected to an analogue input or through fieldbus.
Proportional Quadratic Pressure	The unit increased the pressure setpoint (actual required value) in a quadratic manner in proportion to the flow. The flow can be approximated using the motor speed or measured using a flow sensor connected to an analog input or through fieldbus. The pressure feedback is read through a sensor connected to an analogue input or through fieldbus.
Constant Flow	The unit varies the motor speed to keep a constant flow. The flow feedback is read through a sensor connected to an analogue input or through fieldbus.
Constant Temperature	The unit varies the motor speed to keep a constant temperature. The temperature feedback is read through a sensor connected to an analogue input or through fieldbus.
Constant Level	The unit varies the motor speed to maintain a constant level, for example of a tank or well. The level feedback is ready through a sensor connected to an analogue input or through fieldbus.

3.3 Data plates

The data plate is a label showing:

- The main product details
- The identification code

Approval and certifications

For the approvals see the motor data plate.

3.3.1 hydrovar X nameplates

Motor data plate

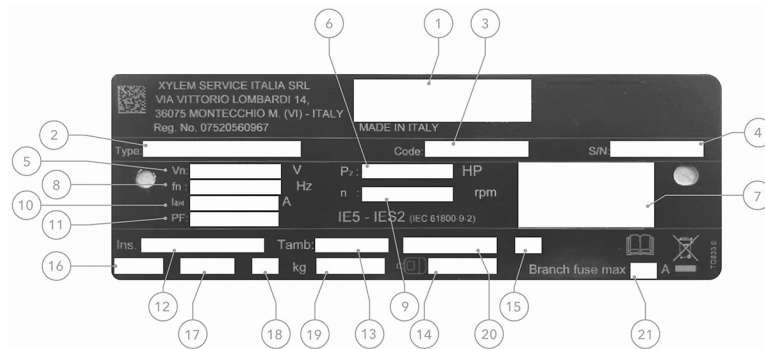

- | | |
|-------------------------------------------------------------------------|------------------------------------------|
| 1. Certification markings (CE, UKCA, UL recognized) | 12. Insulation class |
| 2. Motor type | 13. Ambient operating temperature |
| 3. Motor code | 14. Non-drive end bearing |
| 4. Unique motor serial number | 15. Service factor |
| 5. Voltage range | 16. IP environmental protection rating |
| 6. Output power (kW/HP) | 17. NEMA environmental protection rating |
| 7. Full load rated PDS efficiency (motor and drive combined efficiency) | 18. Weight |
| 8. Frequency compatibility | 19. Drive end bearing |
| 9. Full load rated speed | 20. Duty cycle rating |
| 10. Full load rated current range | 21. Circuit protection requirement |
| 11. Power factor | |

Inverter (drive) data plate

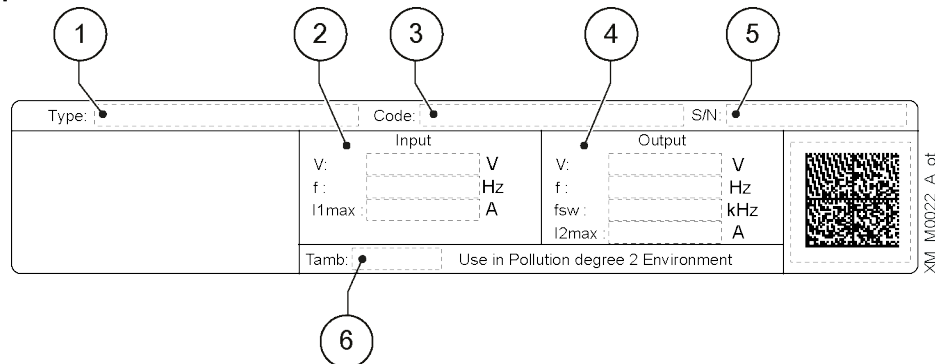

- | | |
|----------------------------|---------------------------|
| 1. Model | 5. Serial number |
| 2. Input operating limits | 6. Room temperature range |
| 3. Identification code | |
| 4. Output operating limits | |

3.4 hydrovar X design layout

The unit can be fitted with the features required by the application.

Figure 1: hydrovar X Smart Motor

EN

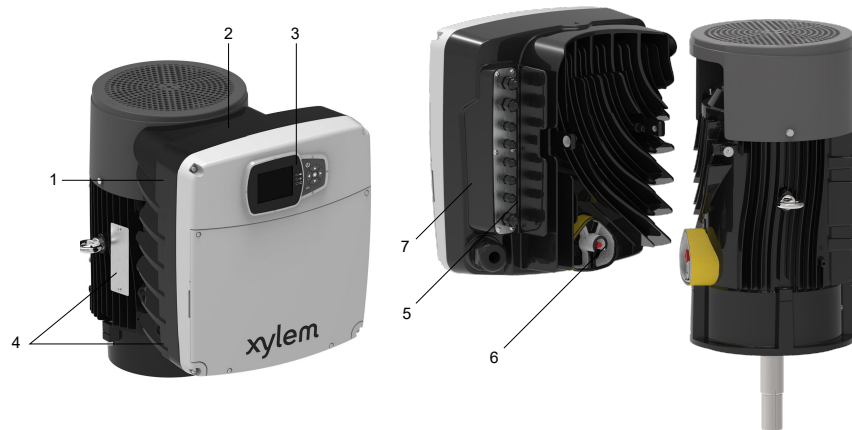

1. Radio equipment approval sticker
2. Drive
3. Drive display
4. Date plate
5. Power supply and signal cable inlets
6. Connection to the motor
7. Drive warning sticker

Cable gland information

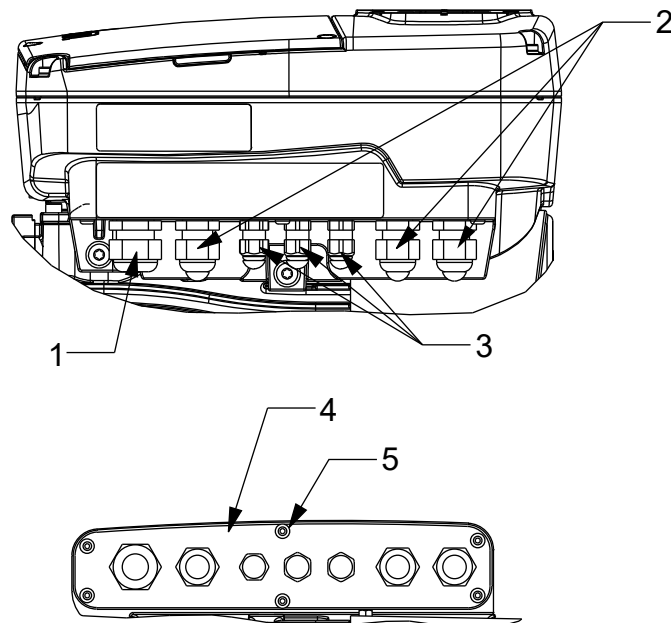

Figure 2: Sizes B and C pre-assembled cable glands

EN

Table 1: Size B

Number	Description	Cable Out Dia. in. [mm]	Gland Plate Opening Dia. In. [mm]
1	M20 cable gland with cap	.265-.512 [7-13]	.886 [22.5] (1/2" trade size)
2	M16 cable gland with cap	.177-.394 [4.5-10]	.638 [16.2]
3	M12 cable gland with cap	.145-.275 [3.7-7]	.480 [12.2]
4	Removable cable gland plate	N/A	N/A
5	M4x12 hex socket button-head screws (x6)	N/A	22.1 in-lb (2.5 Nm)

Table 2: Size C

No.	Description	Cable Out Dia. in. [mm]	Gland Plate Opening Dia. In. [mm]
1	M25 cable gland with cap	.43-.67 [11-17]	1.10 [28] (3/4" trade size)
2	M16 cable gland with cap	.177-.394 [4.5-10]	.638 [16.2]
3	M12 cable gland with cap	.145-.275 [3.7-7]	.480 [12.2]
4	Removable cable gland plate	N/A	N/A
5	M4x12 hex socket button-head screws (x6)	N/A	22.1 in-lb (2.5 Nm)

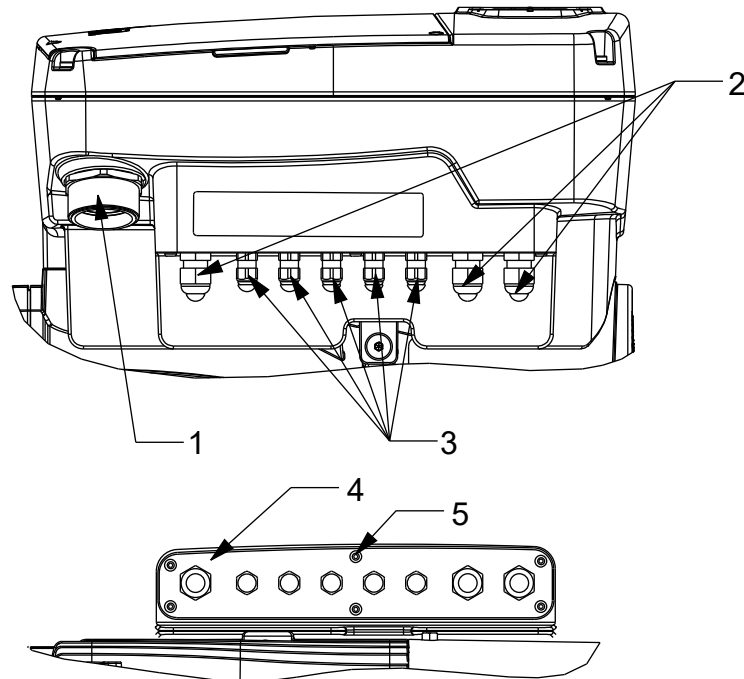

Figure 3: Size D pre-assembled cable glands

Table 3: Size D

Number	Description	Cable Out Dia. in. [mm]	Gland Plate Opening Dia. In. [mm]
1	M40 to 1-1/4" NPSM adapter with cap	1.3 [33] (1-1/4" trade size)	N/A
2	M16 cable gland with cap	.177-.394 [4.5-10]	.638 [16.2]
3	M12 cable gland with cap	.145-.275 [3.7-7]	.480 [12.2]
4	Removable cable gland plate	N/A	N/A
5	M4x12 hex socket button-head screws (x6)	N/A	22.1 in-lb (2.5 Nm)

Other components and options

Table 4: Other components and options

Component	Description
Compatible Sensors	The following sensors can be used with the unit: <ul style="list-style-type: none">• Pressure• Temperature• Flow• Level
Factory-provided sensors	Pressure (x1) optimize® Condition Monitoring (x1) - currently, e-1510X only

EN

4 Installation

4.1 Mechanical installation

4.1.1 Installation area



DANGER:

Potentially explosive atmosphere hazard. The operation of the unit in environments with potentially explosive atmospheres or with combustible dusts (e.g.: wood dust, flour, sugars and grains) is strictly forbidden.

Do not use the unit to handle hazardous or flammable liquid.



WARNING:

- Always wear personal protective equipment.
 - Always use suitable working tools.
 - When selecting the place of installation and connecting the unit to the hydraulic and electric power supplies, strictly comply with current regulations.
 - Ensure that the environmental / ingress protection rating of the unit (Type 3R, IP 55) is suitable for the installation environment.
 - Do NOT install this pump in swimming pools or marine areas. Failure to follow these instructions could result in serious personal injury, death and/or property damage.
-



CAUTION:

- Environmental / ingress protection: to ensure the Type 3R (IP55) protection index is achieved, make sure that the unit is closed correctly.
 - Before opening the terminal box cover, make sure that there is no water in the unit.
 - Make sure that all unused cable glands and cable holes are correctly sealed.
 - Make sure that the plastic cover is correctly closed.
 - Do not leave the terminal box without a cover to avoid the risk of damage due to contamination.
 - Risk of electrical shock or burn. The equipment manufacturer has not evaluated this unit for use in swimming pools.
 - This pump has been evaluated for use with water only.
-

4.1.2 Unit installation

- Position the unit as shown in Figure 4.
- Install the unit according to the liquid flow of the system.
- The arrows on the pump body indicate the flow and the rotation direction.
- The standard rotation direction is clockwise (looking at the fan cover).
- Always install a backflow-prevention device on the suction side.
- Always install the pressure sensor on the delivery side, after the check valve.
- Refer to individual product Installation and Operation Manuals for full details on product-specific installation options.

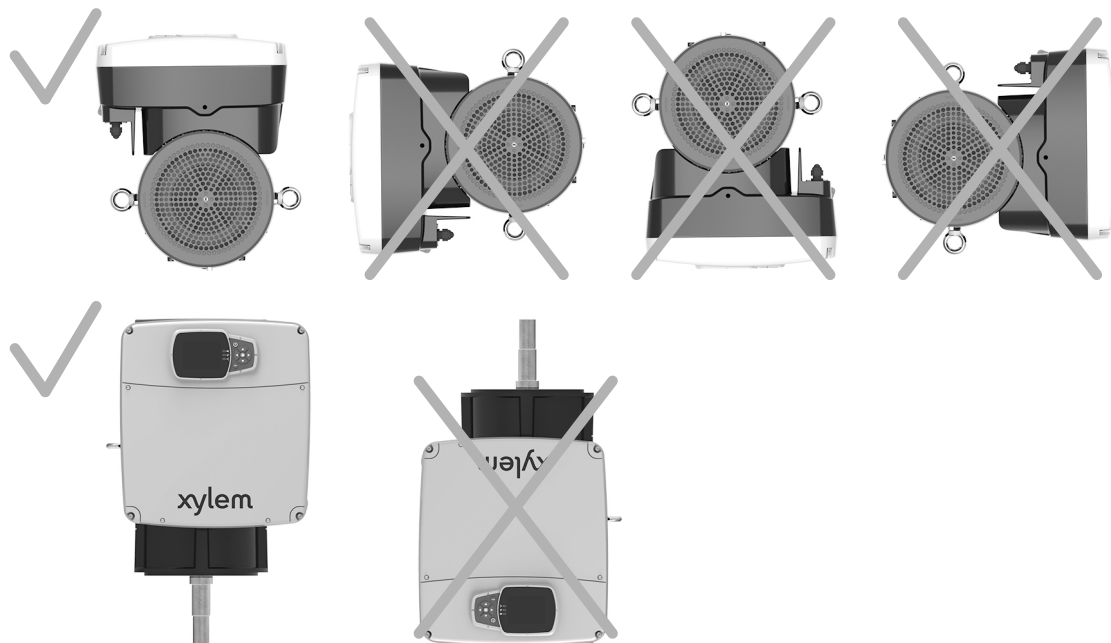

Figure 4: Permitted positions

Minimum spacing

Condition	Free distance surrounding motor
To permit inspection and removal of the motor	≥ 8 in. [203 mm]
To ensure proper ventilation and cooling	≥ 4 in. [100 mm]

4.2 Hydraulic installation

- Install a pressure relief valve sufficient to limit the system pressure below the maximum working pressure of the pump and tank (the minimum of the two). The pressure relief valve must be plumbed to a drain to prevent damage due to flooding.
- Check that the sum of the pressure intake (for example, for the connection with a municipal line or pressure tank) and the maximum pressure of the pump does not exceed the value of the maximum permitted operating pressure of the controller or of the pump (the minimum of the two).
- In cases where the water level is below the suction of the pump (lifting water), install a check valve (foot valve) on the suction of the pump to make sure that the pump stays primed.
- Install a gate valve to allow maintenance of the controller and pump or of the pressure tank.
- It is advisable to install a tap for use during commissioning of the system if there is not already an outlet near the pump.
- The controller plus electric pump can be used to connect the system directly to the municipal supply line or to take water from a primary water supply tank.
- If connecting to a municipal supply, follow the applicable provisions set by the authorities having jurisdiction.
- It is advisable to install a pressure switch on the suction side for turning off the pump if there is low pressure in the in-coming supply line. Protects against dry running.
- If connecting to a primary water supply tank, it is advisable to install a float for turning off the pump when there is no water. Protects against dry running.
- Refer to the instruction manual of the pump for further information.

The following images show a single pump system and a multi-pump system respectively.

EN

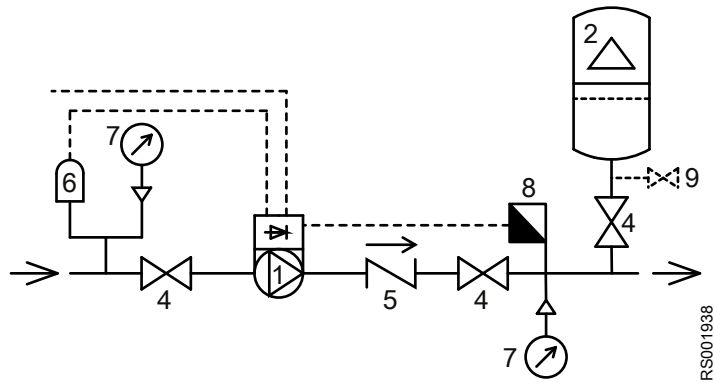

Figure 5: Single-pump system

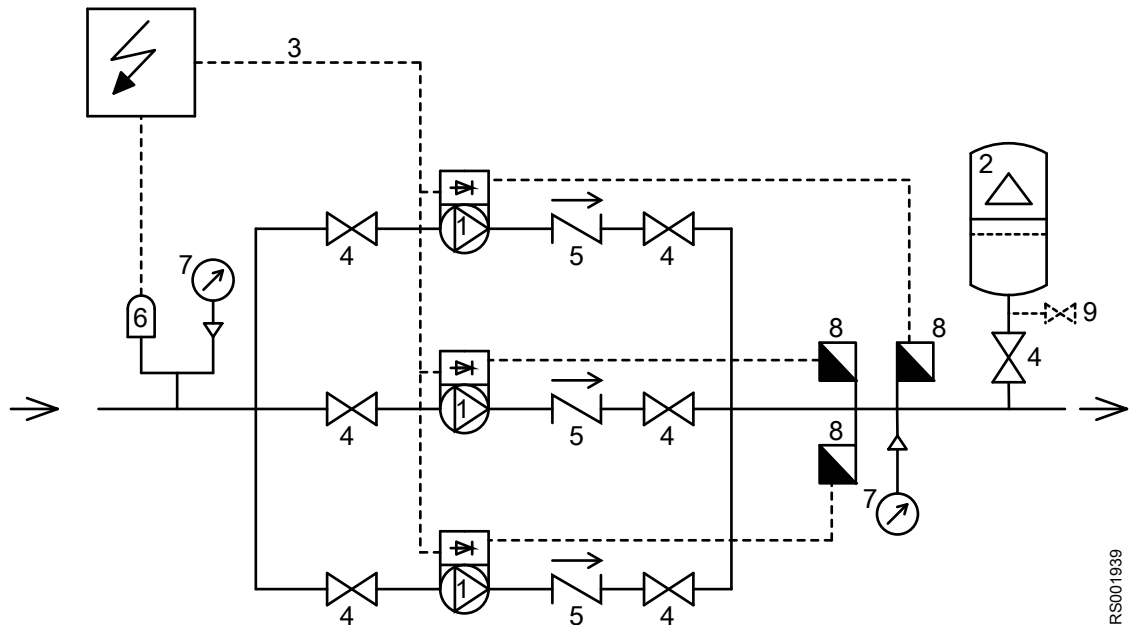

Figure 6: Multi-pump system

- 1. Pump with hydrovar X smart motor
- 2. Diaphragm pressure tank
- 3. Distribution panel
- 4. On-Off valve
- 5. Check valve
- 6. Low water control
- 7. Pressure gauge
- 8. Pressure sensor
- 9. Drain tap

Pressure tank

On the pump delivery side there is a diaphragm pressure tank, which gives the possibility of maintaining the pressure inside the piping when the system is not being used. The unit stops the pump from continuing to run at zero demand and reduce the size of the tank that is required for supply purposes.

Select a tank suitable for the system pressure, and pre-load it in accordance with the values indicated in the Quick Start Guide.

4.3 Electrical installation

4.3.1 Precautions

General precautions

Before starting, make sure that the safety instructions shown in the Introduction and Safety chapter have been fully read and understood.



DANGER:

The connection to the electric power supply must be completed by an electrician possessing the technical-professional requirements outlined in the current regulations.



WARNING:

Always wear personal protective equipment.



WARNING:

Always use suitable working tools.



WARNING:

When selecting the place of installation and connecting the unit to the electric power supplies, strictly comply with current regulations.

Electrical measures



Electrical Hazard:

Before starting work, check that the electric power supply is disconnected and locked out, to avoid unintentional restart of the unit, the control panel and the auxiliary control circuit.

NOTICE:

The mains voltage and frequency must match the values indicated on the drive data plate.

Ground



Electrical Hazard:

Always connect the external protection conductor (ground) to the ground terminal before attempting to make any other electrical connections.



Electrical Hazard:

Connect all the electrical accessories of the unit to the ground.



Electrical Hazard:

Check that the external protection conductor (ground) is longer than the phase conductors. In case of accidental disconnection of the unit from the phase conductors, the protection conductor must be the last one to detach itself from the terminal.

**Electrical Hazard:**

Install suitable systems for protection against indirect contact, in order to prevent lethal electric shocks.

4.3.2 Electrical connection guidelines

Check that electrical leads are protected against:

- High temperature
- Vibrations
- Collisions
- Liquids

Check that the power supply is provided with:

- A short circuit protection device of appropriate size.
- A mains disconnection device with contact opening distance ensuring complete disconnection for undervoltage III category conditions.

4.3.3 Control panel guidelines

NOTICE:

The control panel must match the ratings on the unit data plate.

4.3.4 Fuses and/or circuit breakers

- An electronically activated drive function ensures motor overload protection. The overload protection function calculates the increment level in order to activate the timing of the trigger function (motor stop).
- The drive must be protected against overcurrent and short-circuit protection to prevent the overheating of the power supply cables. Line fuses or circuit breakers must be installed to ensure this protection. Fuses and circuit breakers must be provided by the installer as part of the installation.
- Use the recommended fuses and/or circuit breakers on the power supply side as protection in the event of drive component failure (first failure). The use of the recommended fuses and circuit breakers ensures that possible damage to the drive is limited to the inside of the same. For other types of protection, ensure that the passing energy is equal to or less than that of the recommended models.
- The fuses shown in the table are suitable for use on a circuit capable of releasing 5000 Arms (symmetrical), maximum 480 V. With the indicated fuses, the short-circuit current rating (SCCR) for the drive is 5000 Arms.

HVX model	Xylem motor model/type	Three-phase power supply voltage, Vac	Non-UL fuses, type gG, A	UL fuses, type T, manufacturer and model				MCBT S203 model ABB Circuit Breaker
				Bussmann	Edison	Littelfuse	Ferraz-Shawmut	
B	EXM.../3...B..	200-240	16	JJN-15	TJN (15)	JLLN15	A3T15	C16
C	EXM.../3...C..		30	JJN-30	TJN (30)	JLLN30	A3T30	C32
D	EXM.../3...D..		63	JJN-60	TJN (60)	JLLN60	A3T60	C63

HVX model	Xylem motor model/type	Three-phase power supply voltage, Vac	Non-UL fuses, type gG, A	UL fuses, type T, manufacturer and model				MCBT S203 model ABB Circuit Breaker
				Bussmann	Edison	Littelfuse	Ferraz-Shawmut	
B	EXM.../4...B..	380-480	16	JJS-15	TJS (15)	JLLS15	A6T15	C16
C	EXM.../4...C..		30	JJS-30	TJS (30)	JLLS30	A6T30	C32
D	EXM.../4...D..		63	JJS-60	TJS (60)	JLLS60	A6T60	C63

4.3.5 Residual current devices, RCD (GFCI)

When using ground fault circuit breakers, GFCI, or residual current devices, RCD, also known as automatic earth leakage circuit breakers, ELCD, check that:

- They are suitably sized for the system configuration and environment of use
- They have a starting delay to prevent faults caused by transient ground currents
- They can detect alternate or direct current, they are marked with the symbols shown in the figure.

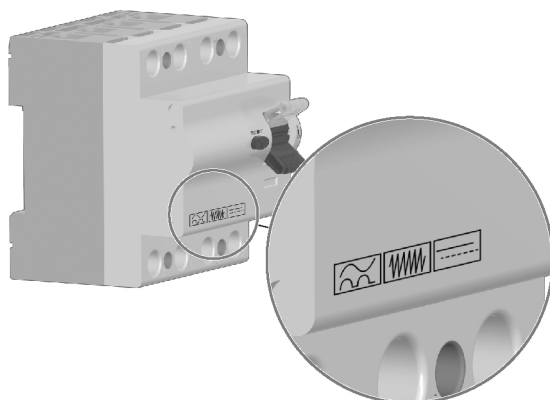

NOTICE:

When using an automatic earth leakage switch or a ground fault switch, make sure to consider the total earth leakage current of all the electric devices of the system.

4.4 Drive guidelines

4.4.1 Drive assembly

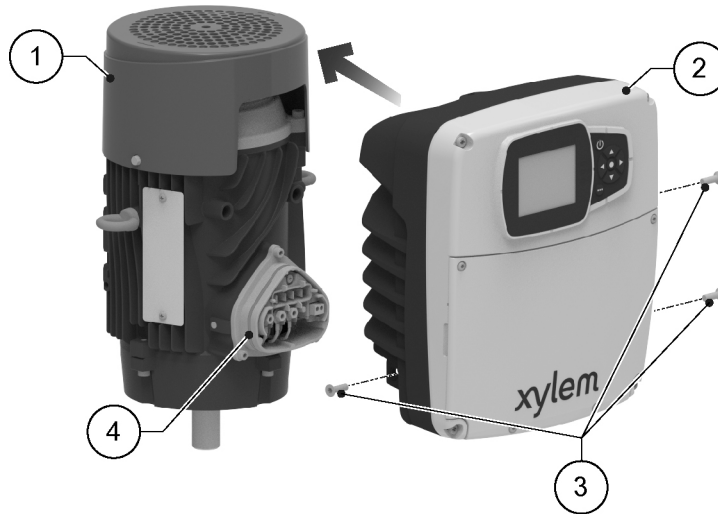

1. Motor
2. Drive
3. Fastening screw
4. Seal

Steps:

1. Lubricate the seal with alcohol.
2. Move the drive close to the motor.
3. Tighten the screws with a Torx spanner.

Tightening torque:

- Size B and C: 6 Nm (55 lbf·in) ± 15%
- Size D: 8 Nm (70 lbf·in) ± 15%

4.4.2 Power supply connection

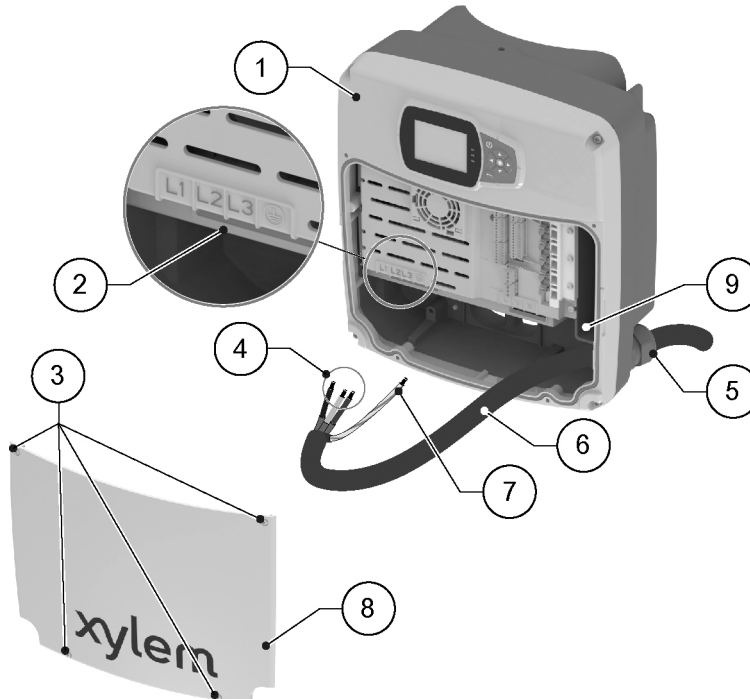

1. Drive
2. Terminals
3. Cover screws
4. Phase conductors
5. Cable gland
6. Power supply cord
7. Protection conductor (ground)
8. Cover
9. Additional ground connection

4.4.3 Power cable installation

1. Remove the cover and observe the wiring diagrams inside.
2. Insert the power cable in the cable gland.
3. Tightly connect the conductors, making sure that the protection one is longer than the phase ones.

For size D only, tighten the terminal screws with a Pozidriv screwdriver.

Tightening torque: 4 Nm (35 lbf-in)

4. Tighten the cable gland.
5. Fit the cover and tighten the screws.

Tightening torque: 3 Nm (27 lbf-in) \pm 15%

4.4.4 Auxiliary connections

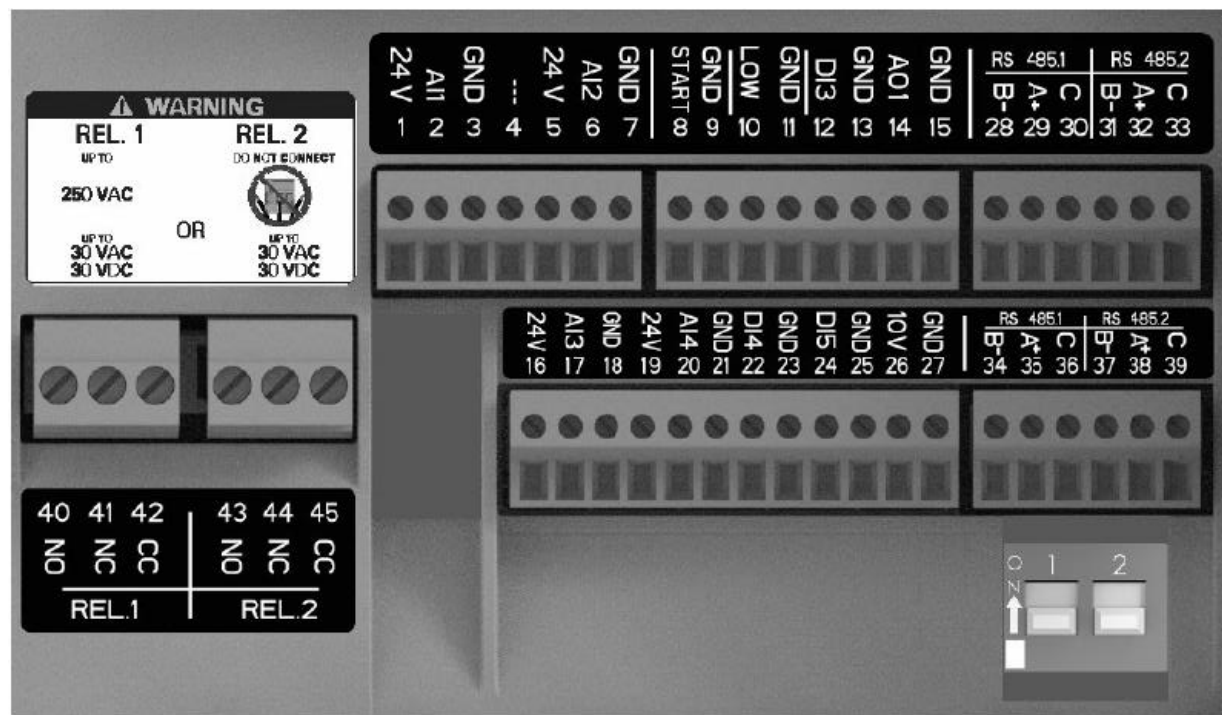

Figure 7: Auxiliary connections

Table 5:

Position number	Name	Description	Default setting
1	Analog input 1	Power supply +24 VDC, max. 60 mA (total, terminals 1 + 5)	Pressure sensor 1
2		Configurable analog input 1	
3		Electronic GND	
4	Reserved	For internal use, do not connect	-
5	Analog input 2	Power supply +24 VDC, max. 60 mA (total, terminals 1 + 5)	Not selected
6		Configurable analog input 2	
7		Electronic GND	
8	External Start/Stop	Digital start/stop input, internal pull-up +24 VDC, contact current 6 mA	-
9		Electronic GND	
10	External lack of water	Low water level digital input, internal pull-up +24 VDC, contact current 6 mA	-
11		Electronic GND	
12	Digital input 3	Configurable digital input 3, internal pull-up + 24 VDC, contact current 6 mA	Emergency start at maximum speed
13		Electronic GND	
14	Analog output	Configurable output	Motor Speed
15		Electronic GND	-
16	Analog input 3	Power supply +24 VDC, max. 60 mA (total, terminals 16 and 19)	Not selected
17		Configurable analog input 3	
18		Electronic GND	
19	Analog input 4	Power supply +24 VDC, max. 60 mA (total, terminals 16 and 19)	Not selected
20		Configurable analog input 4	
21		Electronic GND	
22	Digital Input 4	Configurable digital input 4, internal pull-up +24 VDC, contact current 6 mA	Not selected
23		Electronic GND	
24	Digital Input 5	Configurable digital input 4, internal pull-up +24 VDC, contact current 6 mA	Not selected
25		Electronic GND	
26	10 VDC power supply	Power supply +10 VDC, max. 3 mA	-
27		Electronic GND	
28	Communication Bus 1	RS485 port 1: RS485-1B N(-)	Multipump
29		RS485 port 1: RS485-1A P(+)	
30		RS485 port 1: RS485-COM	
31	Communication Bus 2	RS485 port 2: RS485-2B N(-)	Modbus
32		RS485 port 2: RS485-2A P(+)	
33		RS485 port 2: RS485-COM	
34	Communication Bus 1	RS485 port 1: RS485-1B N(-)	Multipump
35		RS485 port 1: RS485-1A P(+)	
36		RS485 port 1: RS485-COM	

Position number	Name	Description	Default setting
37	Communication Bus 2	RS485 port 2: RS485-2B N(-)	Modbus
38		RS485 port 2: RS485-2A P(+)	
39		RS485 port 2: RS485-COM	
40	Relay 1	Configurable relay 1: normally open	Error reporting
41		Configurable relay 1: normally closed	
42		Configurable relay 1: common contact	
43	Relay 2	Configurable relay 2: normally open	Motor start
44		Configurable relay 2: normally closed	
45		Configurable relay 2: common contact	

EN

5 Operation

EN

5.1 Precautions

In case of coexistence of two or more of the following conditions:

- high ambient temperature
- high water temperature
- duty points insisting on unit maximum power
- persisting undervoltage of mains,

the life of the unit may be jeopardized and/or derating may occur: for further information contact Xylem or the Authorized Distributor.

5.2 Wait times



Electrical Hazard:

Contact with electric components may cause death, even after the unit has been switched off. Before any interventions on the unit, the network voltage and any other input voltages must be disconnected for five minutes.



Electrical Hazard:

Frequency converters contain DC-link capacitors that can stay charged even when the frequency converter is not energized.

To avoid electrical hazards:

- Disconnect the AC power supply.
- Disconnect all types of permanent magnet motors.
- Disconnect all DC-link remote power supplies, including the battery backups, the Uninterrupted Power Supply units and the DC-link connections to other frequency converters.
- Wait five minutes for the capacitors to discharge completely before doing any maintenance or repairs.

6 System Setup and Operation

6.1 Programming precautions

EN

NOTICE:

- Carefully read and adhere to the following instructions before starting the programming activities to avoid incorrect settings that can cause malfunctions.
- All modifications must be done by qualified technicians.

6.2 hydrovar X drive display and controls

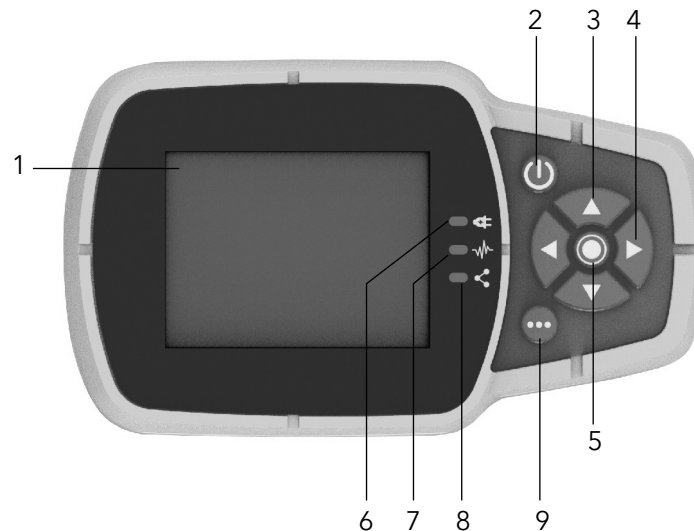

Table 6:

Position number	Name	Function
1	Display	
2	ON/OFF button	<ul style="list-style-type: none"> • Start and stop the unit • Reset the errors by pressing for 5 seconds.
3	UP and DOWN arrow keys	<ul style="list-style-type: none"> • Move vertically between menu options • Perform a manual switch-over on a multi-pump system by pressing the DOWN arrow (extended pressure) • Rotate the display 180° by simultaneously pressing ENTER and the UP arrow (extended pressure).
4	RIGHT and LEFT arrow keys	<ul style="list-style-type: none"> • Move horizontally to navigate home screens and menus • Lock and unlock the display by simultaneously pressing the RIGHT and LEFT arrows (extended pressure).
5	SEND button	<ul style="list-style-type: none"> • Advancing through the menu levels • Confirm the selection of a parameter • Confirm the value of a parameter.
6	Unit LED on	Indicate that the unit is powered.

Position number	Name	Function
7	Unit status LED	Indicate: <ul style="list-style-type: none"> • Motor no powered (off) • Alarm active and motor stopped (yellow) • Unit error and motor stopped (red) • Motor started (green) • Alarm active and motor started (yellow alternating green).
8	Connection status LED	Indicate <ul style="list-style-type: none"> • BMS communication disabled (off) • BMS communication active (green) • Wireless communication with mobile device established (fixed blue) • Wireless communication with mobile device being established (flashing blue) • Wireless communication and BMS communication active (blue alternating green).
9	Multifunction button	<ul style="list-style-type: none"> • Access the parameter menu or additional functions according to the screen on the display. • Enable the unit to a mobile device (extended pressure)

6.3 Graphic display

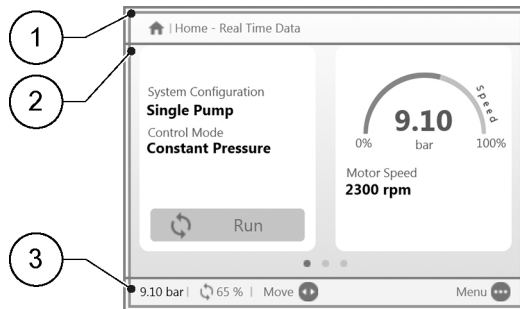

Table 7:

Position number	Name	Description
1	Header bar	Shows static information and messages relating to the operating conditions, such as: <ul style="list-style-type: none"> • Alarms • Errors • Multi-pump operating.
2	Main screen	It shows the main information and allows the operating parameters to be changed. There are up to 5 screens, which can be navigated by pressing the RIGHT and LEFT arrow keys. The symbol next to an entry indicated an editable parameter.
3	Lower bar	Show: <ul style="list-style-type: none"> • On the left, the essential operating information, such as the actual adjustment value and the speed percentage at which the unit is operating • On the right, the buttons available for interaction in the main screen.

6.3.1 hydrovar X parameter menu

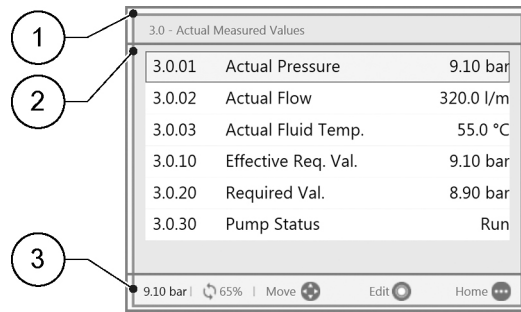

Table 8:

Position number	Name	Description
1	Header bar	It shows the parameter path at menu and submenu level.
2	Parameter list	Shows: <ul style="list-style-type: none"> The index, The name, The preview of the value of the parameters for the current menu level. To advance a level or change the value, press SEND or the RIGHT arrow key.
3	Lower bar	Shows: <ul style="list-style-type: none"> On the left, the essential operating information, such as the actual adjustment value and the speed percentage at which the unit is operating On the right, the buttons available for interaction in the main screen.

The menu is split into 3 levels:

- Main
- Submenu
- Parameters

To display or change a parameter:

1. Press the function button in the main screen.
2. Enter the password using the arrow keys.
3. Press SEND.

NOTICE:

After 10 minutes of inactivity, the password must be re-entered.

4. Press the RIGHT arrow key or SEND to advance between levels, or the LEFT arrow key to return.

6.3.2 Start the unit

NOTICE:

For first-time startup and programming, the unit is equipped with a start-up genie to select the appropriate operating mode and other parameters for the intended application.

1. Check the connection between the START/STOP and GND inputs on the terminal board.
2. Press ON/OFF to start the unit.

NOTICE:

if parameter 1.0.45 Autostart is configured to "Yes", it will not be necessary to press ON/OFF again at the next start.

3. With the unit in operation, the working setpoint can be changed by switching to the second screen.

6.3.3 Operating mode change for hydrovar X

The unit parameters are set at the factory and the unit is ready for use.

To change parameters and advanced features, access the configuration menu.

1. Press the multi-function button.
2. Enter the password using the arrow keys.
3. Press SEND.
4. Navigate through the menus to locate the parameter or function to be changed.

6.3.4 Error reset for hydrovar X

In the event of an error, the unit automatically makes several attempts to reset itself, where permitted: if the attempts are unsuccessful, the unit stops and the display shows the error code.

To eliminate the error:

1. Open the first main screen by pressing SEND.
2. Read the description of the error in the screen.
3. Identify the cause and follow the troubleshooting instructions.
4. Reset the error by pressing and holding down ON/OFF for 3 seconds: the unit returns to the status before the error.

6.4 Xylem X App

Introduction

Available for mobile devices with wireless technology operating system.

Use the App to:

- Check the status of the unit
- Configure parameters
- Interact with the unit and obtain data during installation and maintenance
- Generate a work report
- Contact the assistance service.

Download the App and connect the mobile device with the unit

1. Download the Xylem X App to the mobile device from App Store¹ or Google Play² by scanning the QR code:



2. Complete the registration.
3. On the drive display, press the wireless communication button.

¹ Compatible with iOS® operating systems with version 15.0 and above.

² Compatible with Android operating system with version 10.0 and above.

4. Add the unit to the user profile.
5. When the connection has been established, the connection light turns steady blue. It is now possible to control the unit using the mobile device.

7 Technical Specification

7.1 Operating environment

Non-aggressive and non-explosive atmosphere.

Temperature

-4° to 122°F (-20° to 50°C)

Relative air humidity

<50% at 104°F (40°C)

NOTICE:

If the humidity exceeds the stated limits, contact Xylem or the Authorized Distributor.

Elevation

<3280 ft (1000 m) above sea level.

NOTICE:

Tripping of the inverter's thermal protection. If the inverter is exposed to temperatures or installed at altitudes higher than those indicated, the unit's built-in automatic thermal protection function may intervene. If the unit is installed at an altitude exceeding 6600 ft (2000 m), contact Xylem or the Authorized Distributor.

7.2 Electrical specifications

See the data plate.

Permitted tolerances for the supply voltage

- 200-240 V \pm 10% 50/60 Hz
- 380-480 V \pm 10% 50/60 Hz

Leakage current

\leq 3.5 mA (AC).

Protection class

NEMA 4

7.3 Compliance of radio frequency characteristics

EU/EEA

Table 9:

Features	Description
Technology	Bluetooth® Low Energy 5.2 wireless technology
Band	2.4 GHz ISM
RF	\leq 4.5 mW (6.5 dBm)

USA

hydrovar X FCC ID: 2SYCGXSI03

The variable speed drive is compliant to Part 15 of the FCC Rules (FCC 15.247).

Operation is subject to the following two conditions:

1. This device may not cause harmful interference.
2. This device must accept any interference received, including interference that may cause undesired operation.

The variable speed drive is considered like a mobile device, and it complies with the safety requirements for RF exposure in accordance with FCC rule part 2.1093 and KDB 447498 D01 as demonstrated in the RF exposure analysis.

Installers must ensure that (i) this device must not be co-located or operated in conjunction with any other antenna or transmitter except in accordance with FCC multitransmitter product procedures, (ii) during normal use, there is always a minimum distance of at least 20 cm.

This equipment has been tested and found to comply with the limits for a Class A digital device, pursuant to part 15 of the FCC Rules. These limits are designed to provide reasonable protection against harmful interference when the equipment is operated in a commercial environment.

This equipment generates, uses, and can radiate radio frequency energy and, if not installed and used in accordance with the instruction manual, may cause harmful interference to radio communications. Operation of this equipment in a residential area is likely to cause harmful interference in which case the user will be required to correct the interference at his own expense.

Unauthorized repairs, changes or modifications could result in permanent damage to the equipment and void the warranty and your authority to operate the device under Part 15 of the FCC Rules.

Canada

hydrovar X ISED IC: 26881-XCI03

The variable speed drive is compliant to RSS-247.

Operation is subject to the following two conditions:

1. This device may not cause harmful interference.
2. This device must accept any interference received, including interference that may cause undesired operation.

The variable speed drive is considered like a mobile device, and it complies with the safety requirements for RF exposure in accordance with RSS-102 Issue 5.

Installers must ensure that during normal use, there is always a minimum distance of at least 20 cm.

This device complies with ISED's license-exempt RSSs.

Changes or modifications to this unit not expressly approved by the party responsible for compliance could void the user's authority to operate the equipment.

7.4 Characteristics of inputs and outputs

Features	Description
Communication ports	2, RS-485
Digital inputs (5)	<ul style="list-style-type: none"> • Floating/NPN contact, open manifold/drain open, to GND • Internal polarisation +24 VDC, current limited to 6 mA max. • Protection from -0.5 VDC to +30 VDC, ± 15 mA max.
Analog inputs (4)	<ul style="list-style-type: none"> • Configurable for 0-20 mA current, or 0-10 V voltage • 24V signal for sensor power supply with current limitation 60 mA.
Analog output	Configurable as either 0-20 mA current signal or 0-10 V voltage signal
Relay	2, with NC and NO changeover contact: <ul style="list-style-type: none"> • Relay 1 up to 240 VAC 0.25 A or 30 VDC 2 A • Relay 2 up to 30 VAC 0.25 A or 30 VDC 2 A

**WARNING:**

If relay 1 is connected to a voltage higher than 30 VAC, disconnect and do not use the terminals of relay 2.

7.5 Dimensions and weights

For motor-specific dimensional and weight data, refer to the hydrovar X motor specifications documents where motor drawings are available by speed range, voltage rating, power rating, frame type, and frame size. To understand the motor-pump pairing for a given product and its associated technical data, consult the product-specific technical brochure.

Speed Tier	Motor Type	Voltage Range	Power (hp)	Motor Frame	Specification Document Number	
High Speed	EXM56/4.040BH2	380-480V	4	56	XY-hyXeXM-SUB-520	
	EXM143-145/4.040BH2		4	143-145	XY-hyXeXM-SUB-521	
	EXM143-145/4.055BH2		5.5	143-145	XY-hyXeXM-SUB-522	
	EXM143-145/4.075BH2		7.5	143-145	XY-hyXeXM-SUB-523	
	EXM213-215/4.075CH2		7.5	213-215	XY-hyXeXM-SUB-524	
	EXM213-215/4.100CH2		10	213-215	XY-hyXeXM-SUB-525	
	EXM213-215/4.150CH2		15	213-215	XY-hyXeXM-SUB-526	
	EXM254-256/4.150DH2		15	254-256	XY-hyXeXM-SUB-527	
	EXM254-256/4.200DH2		20	254-256	XY-hyXeXM-SUB-528	
	EXM254-256/4.250DH2		25	254-256	XY-hyXeXM-SUB-529	
	EXM254-256/4.300DH2		30	254-256	XY-hyXeXM-SUB-530	
	EXM56/3.040BH2		200-240V	4	56	XY-hyXeXM-SUB-535
	EXM143-145/3.040BH2			4	143-145	XY-hyXeXM-SUB-536
	EXM213-215/3.075CH2			7.5	213-215	XY-hyXeXM-SUB-537
EXM254-256/3.150DH2	15	254-256		XY-hyXeXM-SUB-538		
EXM254-256/3.200DH2	20	254-256		XY-hyXeXM-SUB-539		
Low Speed	EXM56/4.020BH4	380-480V	2	56	XY-hyXeXM-SUB-542	
	EXM56/4.030BH4		3	56	XY-hyXeXM-SUB-543	
	EXM143-145/4.020BH4		2	143-145	XY-hyXeXM-SUB-544	
	EXM143-145/4.030BH4		3	143-145	XY-hyXeXM-SUB-545	
	EXM213-215/4.040CH4		4	213-215	XY-hyXeXM-SUB-546	
	EXM213-215/4.055CH4		5.5	213-215	XY-hyXeXM-SUB-547	
	EXM213-215/4.075CH4		7.5	213-215	XY-hyXeXM-SUB-548	
	EXM254-256/4.075DH4		7.5	254-256	XY-hyXeXM-SUB-549	
	EXM254-256/4.100DH4		10	254-256	XY-hyXeXM-SUB-550	
	EXM254-256/4.150DH4		15	254-256	XY-hyXeXM-SUB-551	
	EXM56/3.020BH4		200-240V	2	56	XY-hyXeXM-SUB-552
	EXM56/3.030BH4			3	56	XY-hyXeXM-SUB-553
	EXM143-145/3.020BH4			2	143-145	XY-hyXeXM-SUB-554
	EXM143-145/3.030BH4			3	143-145	XY-hyXeXM-SUB-555
	EXM213-215/3.040CH4			4	213-215	XY-hyXeXM-SUB-556
	EXM213-215/3.055CH4			5.5	213-215	XY-hyXeXM-SUB-557
EXM213-215/3.075CH4	7.5	213-215		XY-hyXeXM-SUB-558		

	EXM254-256/3.075DH4		7.5	254-256	XY-hyXeXM-SUB-559
	EXM254-256/3.100DH4		10	254-256	XY-hyXeXM-SUB-560
	EXM254-256/3.150DH4		15	254-256	XY-hyXeXM-SUB-561

View or download the specification documents listed above:

EN



8 Cybersecurity

EN

Xylem values system security and resilience. Defending against cybersecurity threats is a shared responsibility. Xylem builds products that are secure by design. Our customers have a responsibility to understand the risks inherent in their processes and take steps to operate and maintain their solutions securely. This section reviews security features and provides guidance to help securely operate this product. For details and updates on Xylem product cybersecurity visit xylem.com/security

8.1 Xylem product cybersecurity

Xylem performs appropriate due care in building security and resilience into products. Xylem performs the following security activities for defense-in-depth:

- Security engineers perform **threat modeling** to identify **testable controls**
- Code is scanned for flaws with **static analysis** tools and hardened
- **Product components are analyzed** and hardened
- Security controls are verified through **automated and manual tests**
- Xylem maintains relationships with customers, integrators, and the cybersecurity research community and the **Product Security Incident Response Team (PSIRT)** coordinates the collection, analysis, remediation, and responsible disclosure of vulnerability and remediation information to keep products secure
- Cloud connections, data flows, and cloud infrastructure are continuously monitored by the **Product Security Operations Center (PSOC)**
- Product security is **governed through a three lines of defense** model that includes: product developers, product security engineers, and audit staff

8.2 Security recommendations for end-user

Hydrovar X is developed considering security best practices. The following guidance provides recommendation for secure operations, hardening and account management. In the table below: *Safeguards* describe the security guidance, *Security Context & Rationale* provide overview of security features and value of the security safeguard, and *References* provide additional resources for further investigation for implementing the recommended safeguards.

Table 10:

Safeguard	Security Context & Rationale	References
Restrict physical access <ul style="list-style-type: none"> • Ensure physical access to assets is limited. Include physical isolation to protect the environment and equipment therein. • Ensure strict control over physical access in and out of the facility. 	The communication ports have been hardened to restrict access and ensure integrity of device operations. This safeguard supports the ability to further limit exposure associated with physical threats to the device such as rogue/malicious device joining the Modbus RTU network over RS485 interface.	ATT&CK for ICS: M0801 NIST SP 800-53 Rev5: AC-3, PE-3 ISA/IEC 62443-3-3: SR 2.1

Safeguard	Security Context & Rationale	References
<p>Ensure that the device is not exposed to internet, using below recommendations:</p> <ul style="list-style-type: none"> • Implement firewall & define rules to protect device from Denial-of-service attempts. • Protect the network address information of device using Network Address Translation (NAT) technique. 	<p>This safeguard ensures that data and SCADA controls are not exposed to internet. This also helps in preventing Man-in-the-middle attacks when the device is accessed via Modbus over TCP/IP or BACnet IP.</p> <p>We recommend using network segmentation and segregation to minimize access to sensitive information for those systems and people who don't need it, while ensuring that the organization can continue to operate effectively.</p>	<p>ATT&CK for ICS: M0930 NIST SP 800-95 NIST SP 800-44 v2 ISA/IEC 62443-3-3: SR 5.1, SR 7.1</p>
<p>Ensure cybersecurity policies, awareness, and training to the operators, administrators and other personnel.</p>	<p>This safeguard prevents Social Engineering attacks and promotes awareness related to cybersecurity.</p>	<p>ATT&CK for ICS: M0917 NIST SP 800-53 Rev5: AT-2 ISA/IEC 62443-2-4: SP.01</p>
<p>Ensure patch management is done regularly and updated appropriately.</p>	<p>This safeguard prevents attacks related using components with known vulnerabilities. Sometime vulnerabilities are discovered, and we work with our partners to deploy updates to security and resilience. This safeguard mitigates exploitation risks and ensures security patching</p>	<p>ATT&CK for ICS: M0951 NIST SP 800-53 Rev5: MA-2 ISA/IEC 62443-2-3</p>
<p>Ensure hardening guidelines are implemented, only desired ports and services should be open, and RBAC should be followed.</p>	<p>This safeguard helps in prevention of attacks due to misconfigurations or default configurations.</p>	<p>ATT&CK for ICS: M0937, M0918, M0801 NIST SP 800-53 Rev5: AC-3(7), SC-7(5) ISA/IEC 62443-3-3: SR 2.1, SR 5.1</p>
<p>Ensure strong password policy is implemented and default credentials should not be used, passwords must be changed periodically.</p>	<p>This safeguard will help in prevention of passwords and account takeover attacks.</p>	<p>ATT&CK for ICS: M0927 NIST SP 800-53 Rev5: IA-5 ISA/IEC 62443-3-3: SR 1.7</p>
<p>Create and exercise disaster recovery plans.</p>	<p>hydrovar X has no way to perform back-ups of the current system configuration. A copy of the current configuration can be downloaded using the app. The configuration can be restored manually from this copy, or the configuration can revert to factory settings via Display or via Modbus. Defining this process provides system resilience, including against ransomware.</p>	<p>ATT&CK for ICS: M0953 NIST SP 800-53 Rev5: CP-10 ISA/IEC 62443-3-3: SR 7.4</p>
<p>Implement specific inventory, logging and monitoring of hardware and report security-related incidents to Xylem at product.security@xylem.com. These might include unexpected operations, confirmed tampering, or theft of the device.</p>	<p>Devices are hardened and Xylem provides PSIRT to help customers investigate potential security incidents. This safeguard supports the ability to track assets and recognize potential security events.</p>	<p>ATT&CK for ICS: M0947 NIST SP 800-53 Rev5: SM-8 ISA/IEC 62443-3-3: SR 1.11, SR 2.8, SR 3.4</p>

For additional information see references:

1. ATT&CK for ICS available online: <https://attack.mitre.org/mitigations/ics/>
2. NIST SP 800-53 Rev 5 available online: <https://nvlpubs.nist.gov/nistpubs/SpecialPublications/NIST.SP.800-53r5.pdf>
3. ISA/IEC 62443 standards available for purchase from ISA, IEC, or ANSI.

EN

9 Product Warranty

Commercial warranty

EN

Warranty. For goods sold to commercial buyers, Seller warrants the goods sold to Buyer hereunder (with the exception of membranes, seals, gaskets, elastomer materials, coatings and other “wear parts” or consumables all of which are not warranted except as otherwise provided in the quotation or sales form) will be (i) be built in accordance with the specifications referred to in the quotation or sales form, if such specifications are expressly made a part of this Agreement, and (ii) free from defects in material and workmanship for a period of two and a half (2.5) years from the date of installation or three (3) years from the date of shipment (which date of shipment shall not be greater than thirty (30) days after receipt of notice that the goods are ready to ship), whichever shall occur first, unless a longer period is specified in the product documentation (the “Warranty”).

Except as otherwise required by law, Seller shall, at its option and at no cost to Buyer, either repair or replace any product which fails to conform with the Warranty provided Buyer gives written notice to Seller of any defects in material or workmanship within ten (10) days of the date when any defects or non-conformance are first manifest. Under either repair or replacement option, Seller shall not be obligated to remove or pay for the removal of the defective product or install or pay for the installation of the replaced or repaired product and Buyer shall be responsible for all other costs, including, but not limited to, service costs, shipping fees and expenses. Seller shall have sole discretion as to the method or means of repair or replacement. Buyer’s failure to comply with Seller’s repair or replacement directions shall terminate Seller’s obligations under this Warranty and render the Warranty void. Any parts repaired or replaced under the Warranty are warranted only for the balance of the warranty period on the parts that were repaired or replaced. Seller shall have no warranty obligations to Buyer with respect to any product or parts of a product that have been: (a) repaired by third parties other than Seller or without Seller’s written approval; (b) subject to misuse, misapplication, neglect, alteration, accident, or physical damage; (c) used in a manner contrary to Seller’s instructions for installation, operation and maintenance; (d) damaged from ordinary wear and tear, corrosion, or chemical attack; (e) damaged due to abnormal conditions, vibration, failure to properly prime, or operation without flow; (f) damaged due to a defective power supply or improper electrical protection; or (g) damaged resulting from the use of accessory equipment not sold or approved by Seller. In any case of products not manufactured by Seller, there is no warranty from Seller; however, Seller will extend to Buyer any warranty received from Seller’s supplier of such products.

THE FOREGOING WARRANTY IS EXCLUSIVE AND IN LIEU OF ANY AND ALL OTHER EXPRESS OR IMPLIED WARRANTIES, GUARANTEES, CONDITIONS OR TERMS OF WHATEVER NATURE RELATING TO THE GOODS PROVIDED HEREUNDER, INCLUDING WITHOUT LIMITATION ANY IMPLIED WARRANTIES OF MERCHANTABILITY AND FITNESS FOR A PARTICULAR PURPOSE, WHICH ARE HEREBY EXPRESSLY DISCLAIMED AND EXCLUDED. EXCEPT AS OTHERWISE REQUIRED BY LAW, BUYER’S EXCLUSIVE REMEDY AND SELLER’S AGGREGATE LIABILITY FOR BREACH OF ANY OF THE FOREGOING WARRANTIES ARE LIMITED TO REPAIRING OR REPLACING THE PRODUCT AND SHALL IN ALL CASES BE LIMITED TO THE AMOUNT PAID BY THE BUYER FOR THE DEFECTIVE PRODUCT. IN NO EVENT SHALL SELLER BE LIABLE FOR ANY OTHER FORM OF DAMAGES, WHETHER DIRECT, INDIRECT, LIQUIDATED, INCIDENTAL, CONSEQUENTIAL, PUNITIVE, EXEMPLARY OR SPECIAL DAMAGES, INCLUDING BUT NOT LIMITED TO LOSS OF PROFIT, LOSS OF ANTICIPATED SAVINGS OR REVENUE, LOSS OF INCOME, LOSS OF BUSINESS, LOSS OF PRODUCTION, LOSS OF OPPORTUNITY OR LOSS OF REPUTATION.

Limited consumer warranty

Warranty. For goods sold for personal, family or household purposes, Seller warrants the goods purchased hereunder (with the exception of membranes, seals, gaskets, elastomer materials, coatings and other “wear parts” or consumables all of which are not warranted except as otherwise provided in the quotation or sales form) will be free from defects in material and workmanship for a period of one (1) year from the date of installation or eighteen (18) months from the product date code, whichever shall occur first, unless a longer period is provided by law or is specified in the product documentation (the “Warranty”).

Except as otherwise required by law, Seller shall, at its option and at no cost to Buyer, either repair or replace any product which fails to conform with the Warranty provided Buyer gives written notice to Seller of any defects in material or workmanship within ten (10) days of the date when any defects or non-conformance are first manifest. Under either repair or replacement option, Seller shall not be obligated to remove or pay for the removal of the defective product or install or pay for the installation of the replaced or repaired product and Buyer shall be responsible for all other costs, including, but not limited to, service costs, shipping fees and expenses. Seller shall have sole discretion as to the method or means of repair or replacement. Buyer’s failure to comply with Seller’s repair or replacement directions shall terminate Seller’s obligations under this Warranty and render this Warranty void. Any parts repaired or replaced under the Warranty are warranted only for the balance of the warranty period on the parts that were repaired or replaced. The Warranty is conditioned on Buyer giving written notice to Seller of any defects in material or workmanship of warranted goods within ten (10) days of the date when any defects are first manifest.

Seller shall have no warranty obligations to Buyer with respect to any product or parts of a product that have been: (a) repaired by third parties other than Seller or without Seller’s written approval; (b) subject to misuse, misapplication, neglect, alteration, accident, or physical damage; (c) used in a manner contrary to Seller’s instructions for installation, operation and maintenance; (d) damaged from ordinary wear and tear, corrosion, or chemical attack; (e) damaged due to abnormal conditions, vibration, failure to properly prime, or operation without flow; (f) damaged due to a defective power supply or improper electrical protection; or (g) damaged resulting from the use of accessory equipment not sold or approved by Seller. In any case of products not manufactured by Seller, there is no warranty from Seller; however, Seller will extend to Buyer any warranty received from Seller’s supplier of such products

THE FOREGOING WARRANTY IS PROVIDED IN PLACE OF ALL OTHER EXPRESS WARRANTIES. ALL IMPLIED WARRANTIES, INCLUDING BUT NOT LIMITED TO THE IMPLIED WARRANTIES OF MERCHANTABILITY AND FITNESS FOR A PARTICULAR PURPOSE, ARE LIMITED TO ONE (1) YEAR FROM THE DATE OF INSTALLATION OR EIGHTEEN (18) MONTHS FROM THE PRODUCT DATE CODE, WHICHEVER SHALL OCCUR FIRST. EXCEPT AS OTHERWISE REQUIRED BY LAW, BUYER’S EXCLUSIVE REMEDY AND SELLER’S AGGREGATE LIABILITY FOR BREACH OF ANY OF THE FOREGOING WARRANTIES ARE LIMITED TO REPAIRING OR REPLACING THE PRODUCT AND SHALL IN ALL CASES BE LIMITED TO THE AMOUNT PAID BY THE BUYER FOR THE DEFECTIVE PRODUCT. IN NO EVENT SHALL SELLER BE LIABLE FOR ANY OTHER FORM OF DAMAGES, WHETHER DIRECT, INDIRECT, LIQUIDATED, INCIDENTAL, CONSEQUENTIAL, PUNITIVE, EXEMPLARY OR SPECIAL DAMAGES, INCLUDING BUT NOT LIMITED TO LOSS OF PROFIT, LOSS OF ANTICIPATED SAVINGS OR REVENUE, LOSS OF INCOME, LOSS OF BUSINESS, LOSS OF PRODUCTION, LOSS OF OPPORTUNITY OR LOSS OF REPUTATION.

Some states do not allow limitations on how long an implied warranty lasts, so the above limitation may not apply to you. Some states do not allow the exclusion or limitation of incidental or consequential damages, so the above exclusions may not apply to you. This warranty gives you specific legal rights, and you may also have other rights which may vary from state to state.

To make a warranty claim, check first with the dealer from whom you purchased the product or visit www.xylem.com for the name and location of the nearest dealer providing warranty service.

Xylem |'zīləm|

- 1) The tissue in plants that brings water upward from the roots;
- 2) a leading global water technology company.

We're a global team unified in a common purpose: creating advanced technology solutions to the world's water challenges. Developing new technologies that will improve the way water is used, conserved, and re-used in the future is central to our work. Our products and services move, treat, analyze, monitor and return water to the environment, in public utility, industrial, residential and commercial building services settings. Xylem also provides a leading portfolio of smart metering, network technologies and advanced analytics solutions for water, electric and gas utilities. In more than 150 countries, we have strong, long-standing relationships with customers who know us for our powerful combination of leading product brands and applications expertise with a strong focus on developing comprehensive, sustainable solutions.

For more information on how Xylem can help you, go to www.xylem.com



Xylem Inc.
8200 N. Austin Avenue
Morton Grove, IL 60053
Tel: (847) 966-3700
Fax: (847) 965-8379
www.xylem.com/bellgossett

Visit our Web site for the latest version of this document and more information

The original instruction is in English. All non-English instructions are translations of the original instruction.

© 2024 Xylem Inc.

Bell & Gossett is a trademark of Xylem Inc. or one of its subsidiaries. All other trademarks or registered trademarks are property of their respective owners.