

TECHNOFORCE e-HVX & e-HVXR Packaged Booster Systems

Page intentionally left blank

Table of Contents

1	Introduction and Safety.....	3
1.1	Introduction.....	3
1.2	Safety.....	3
1.2.1	Safety terminology and symbols.....	3
1.2.2	Protecting the environment.....	4
1.3	User safety.....	4
1.3.1	Wash the skin and eyes.....	5
2	Transportation and Storage.....	7
2.1	Examine the delivery.....	7
2.1.1	Examine the package.....	7
2.1.2	Examine the unit.....	7
2.2	Transportation guidelines.....	7
2.2.1	Lifting methods.....	7
2.3	Storage guidelines.....	7
2.3.1	Long term storage.....	8
3	Product Description.....	10
3.1	General description.....	10
3.1.1	Operational limits.....	10
3.2	Nameplate information.....	10
4	Installation.....	12
4.1	Reference manuals.....	12
4.2	Field connections.....	12
4.3	Ground (earth) and Power connections.....	13
4.4	Packaged booster system location guidelines.....	13
4.5	Foundation requirements.....	14
4.6	Level the base on a concrete foundation	14
4.7	Grout the baseplate.....	15
4.8	Piping checklist.....	15
4.9	Xylem App setup.....	15
5	Commissioning, Startup, Operation, and Shutdown.....	17
5.1	Preparation for startup.....	17
5.1.1	Prestartup checklist.....	17
5.1.2	Final installation checks.....	17
5.1.3	Final adjustments.....	18
5.2	Pump station startup.....	18
5.2.1	Confirm the job site voltage.....	18
5.2.2	Connect the expansion tank.....	18
5.2.3	Filling and priming.....	19
5.2.4	Power the packaged booster system.....	19
5.2.5	Configure the package system using the startup Genie.....	19
5.2.6	Startup.....	20
5.2.7	Test the packaged booster system.....	20
5.2.8	Final checks.....	21
5.2.9	Manual Stop.....	21

6	Maintenance.....	22
6.1	Precautions.....	22
6.2	Maintenance.....	22
6.2.1	Monthly maintenance.....	22
6.2.2	Maintenance every 3 months.....	22
6.2.3	Maintenance every year, or 4000 hours of operation.....	22
6.2.4	Maintenance every 2 years, or 10,000 hours of operation.....	23
6.2.5	Maintenance every 5 years, or 17,500 hours of operation.....	23
7	Troubleshooting.....	24
7.1	Pump station troubleshooting.....	24
7.1.1	The pump station does not power up.....	24
7.1.2	The station powers up, but the pumps do not run.....	24
7.1.3	The pumps run but do not build desired pressure.....	25
7.1.4	The pump station experiences excessive vibration.....	25
7.1.5	The pump station does not shut down and no water is used.....	26
7.1.6	The pump station cycles or hunts erratically.....	26
7.1.7	The pump system does not stop when the setpoint is reached.....	27
7.1.8	The pump is leaking at the mechanical seal.....	27
7.1.9	The drive display does not turn on.....	27
7.1.10	The pump system runs at maximum speed without stopping.....	27
7.1.11	Only one pump of the multi-pump set is working.....	27
7.1.12	The pump does not start when there is liquid demand.....	28
7.1.13	hydrovar X unit error or alarm.....	28
8	Product Nomenclature.....	29
8.1	Pump station numbering system.....	29
8.1.1	Pump station with e-SV pumps.....	29
9	Appendix.....	33
9.1	Installation drawings.....	33
9.2	Sound pressure.....	35
9.3	Dimensions and weights.....	35
10	Product Warranty.....	37

1 Introduction and Safety

1.1 Introduction

Purpose of this manual

The purpose of this manual is to provide necessary information for:

- Installation
- Operation
- Maintenance



CAUTION:

Read this manual carefully before installing and using the product. Improper use of the product can cause personal injury and damage to property, and may void the warranty.

NOTICE:

Save this manual for future reference, and keep it readily available at the location of the unit.

1.2 Safety



WARNING:

- The operator must be aware of safety precautions to prevent physical injury.
- Operating, installing, or maintaining the unit in any way that is not covered in this manual could cause death, serious personal injury, or damage to the equipment. This includes any modification to the equipment or use of parts not provided by Xylem. If there is a question regarding the intended use of the equipment, please contact a Xylem representative before proceeding.
- Do not change the service application without the approval of an authorized Xylem representative.



CAUTION:

You must observe the instructions contained in this manual. Failure to do so could result in physical injury, damage, or delays.

1.2.1 Safety terminology and symbols



About safety messages

It is extremely important that you read, understand, and follow the safety messages and regulations carefully before handling the product. They are published to help prevent these hazards:

- Personal accidents and health problems
- Damage to the product and its surroundings
- Product malfunction



Hazard levels

Hazard level	Indication
 DANGER:	A hazardous situation which, if not avoided, will result in death or serious injury

Hazard level	Indication
 WARNING:	A hazardous situation which, if not avoided, could result in death or serious injury
 CAUTION:	A hazardous situation which, if not avoided, could result in minor or moderate injury
NOTICE:	Notices are used when there is a risk of equipment damage or decreased performance, but not personal injury.

Special symbols

Some hazard categories have specific symbols, as shown in the following table.

Electrical hazard	Magnetic fields hazard
 Electrical Hazard:	 CAUTION:

1.2.2 Protecting the environment

Emissions and waste disposal

Observe the local regulations and codes regarding:

- Reporting of emissions to the appropriate authorities
- Sorting, recycling and disposal of solid or liquid waste
- Clean-up of spills

Exceptional sites



CAUTION: Radiation Hazard

Do NOT send the product to Xylem if it has been exposed to nuclear radiation, unless Xylem has been informed and appropriate actions have been agreed upon.

Recycling guidelines

Always follow local laws and regulations regarding recycling.

1.3 User safety

General safety rules

These safety rules apply:

- Always keep the work area clean.
- Pay attention to the risks presented by gas and vapors in the work area.
- Avoid all electrical dangers. Pay attention to the risks of electric shock or arc flash hazards.
- Always bear in mind the risk of drowning, electrical accidents, and burn injuries.

Safety equipment

Use safety equipment according to the company regulations. Use this safety equipment within the work area:

- Hard hat
- Safety goggles, preferably with side shields
- Protective shoes
- Protective gloves
- Gas mask
- Hearing protection
- First-aid kit
- Safety devices

NOTICE:

Never operate a unit unless safety devices are installed. Also see specific information about safety devices in other chapters of this manual.

Electrical connections

Electrical connections must be made by certified electricians in compliance with all international, national, state, and local regulations. For more information about requirements, see sections dealing specifically with electrical connections.

Precautions during work

Observe these safety precautions when you work with the product or are in connection with the product:

- Never work alone.
- Always wear protective clothing and hand protection.
- Stay clear of suspended loads.
- Always lift the product by its lifting device.
- Beware of the risk of a sudden start if the product is used with an automatic level control.
- Beware of the starting jerk, which can be powerful.
- Rinse the components in water after you disassemble the pump.
- Do not exceed the maximum working pressure of the pump.
- Do not open any vent or drain valve or remove any plugs while the system is pressurized. Make sure that the pump is isolated from the system and that pressure is relieved before you disassemble the pump, remove plugs, or disconnect piping.
- Never operate a pump without a properly installed coupling guard.

1.3.1 Wash the skin and eyes

Follow these procedures for chemicals or hazardous fluids that have come into contact with your eyes or your skin:

Condition	Action
Chemicals or hazardous fluids in eyes	<ol style="list-style-type: none"> 1. Hold your eyelids apart forcibly with your fingers. 2. Rinse the eyes with eyewash or running water for at least 15 minutes. 3. Seek medical attention.
Chemicals or hazardous fluids on skin	<ol style="list-style-type: none"> 1. Remove contaminated clothing. 2. Wash the skin with soap and water for at least 1 minute. 3. Seek medical attention, if necessary.

Lockout/Tagout provisions**DANGER:**

Electrical hazard sufficient to kill. Always disconnect and lock out the power before you service the unit.

**WARNING:**

- Always disconnect and lock out power to the driver before you perform any installation or maintenance tasks. Failure to disconnect and lock out driver power will result in serious physical injury.

The main station panel is equipped with a main station disconnect for completely powering down the system. This panel also provides individual circuit breaker service disconnects for each pump. These disconnects are accessible without disengaging the main station disconnect to ensure that operation of the system is not interrupted during individual pump service. In both situations (complete station or individual pump power down), provisions for lockout / tagout capability have been provided.

The main station disconnect has a door interlocking feature that utilizes a handle that allows for padlocking.



2 Transportation and Storage

2.1 Examine the delivery

EN

2.1.1 Examine the package

1. Examine the package for damaged or missing items upon delivery.
2. Record any damaged or missing items on the receipt and freight bill.
3. If anything is out of order, then file a claim with the shipping company.
If the product has been picked up at a distributor, make a claim directly to the distributor.

2.1.2 Examine the unit

1. Remove packing materials from the product.
Dispose of all packing materials in accordance with local regulations.
2. To determine whether any parts have been damaged or are missing, examine the product.
3. If applicable, unfasten the product by removing any screws, bolts, or straps.
Use care around nails and straps.
4. If there is any issue, then contact a sales representative.

2.2 Transportation guidelines

2.2.1 Lifting methods



WARNING:

- Assembled units and their components are heavy. Failure to properly lift and support this equipment can result in serious physical injury and/or equipment damage. Lift equipment only at the specifically identified lifting points. Lifting devices such as eyebolts, slings, and spreaders must be rated, selected, and used for the entire load being lifted.
 - Crush hazard. The unit and the components can be heavy. Use proper lifting methods and wear steel-toed shoes at all times.
 - Tip over hazard. Do not use component eyebolts to lift the pump station. The eyebolts are only designed to lift the components to which they are attached.
 - Do not attach sling ropes to the panel stand.
-

2.3 Storage guidelines

Storage location

The product must be stored in a covered and dry location free from heat, dirt, and vibrations.

NOTICE:

Protect the product against humidity, heat sources, and mechanical damage.

NOTICE:

Do not place heavy weights on the packed product.

Storage between use

Observe the following for long-term storage of a pump station.

- Ensure system is drained of any water.
- Remove transducers to ensure that they do not freeze.
- System may be top-heavy, brace to keep from tipping.

2.3.1 Long term storage

The following procedure applies to **Booster and HVAC Packaged Systems**.

1. Customer furnished equipment and accessories that are not offered as standard or optional by the factory must be handled in accordance with the respective manufacturer's recommendations.
2. Storage longer than one month is considered long term storage.
3. Pumps should be prepared for storage using the following procedure.

SAFETY

- Select a storage location that will prevent potential hazards to persons allowed access to the storage area.
- Appropriate precautions should be taken to ensure safe on-site receipt and transit.
- Potential energy risk should be minimized. Keep product at ground level and prevent stacking or other unsafe positioning that could result in falling, dropping, and/or tipping.

LOCATION AND TREATMENT

- Indoor Storage
 - Little extra preparation is needed if indoor storage area is dry and clean.
 - Care should be taken to prevent extremes in temperature (below 32°F and above 110°F). Also, keep the pump system covered to protect it from dust and dirt.
 - Care should be taken to prevent moisture build-up around the pump system, either by allowing proper ventilation or tightly sealing the pump system with a cover with a suitable amount of desiccant to ensure dryness.
 - If indoor storage area is humid or dirty, such as an unfinished building, treat the pump as if it were to be stored outdoors.
 - If exposure to condensation is expected, un-painted external steel or cast-iron surfaces should be coated with rust-inhibiting oil such as Cortec's VCI-329.
 - Storage location should also provide minimal exposure to vibration and other damage potentially transmitted from adjacent operating equipment.
 - Product supplied in factory cartons, pallets or similar Xylem packaging should be kept in 'as-shipped' condition where possible.
 - Inspect suction and discharge manifold flange covers.
- Outdoor Storage
 - Pump system should be covered to protect it from weather and direct sunlight.
 - All coverings should be properly secured to withstand high wind.
 - Care must be exercised in covering pumps to prevent moisture build-up under the cover. This can be done either by allowing proper ventilation or with a sealing cover with suitable amount of desiccant to ensure dryness.
 - Extreme heat and cold are to be avoided, as rubber parts and seals could age prematurely (below 32°F and above 110°F).
 - Storage area should be inspected weekly, and after storms for damage to protective covers.
 - Inspect suction and discharge manifold flange covers.
- Installed But Not in Service
 - Preparation for storage under these conditions is the same as for indoor and outdoor, except the suction and discharge piping will serve as flange covers.
 - The suction and discharge valves must be tightly closed and all water removed from the pump system and attached piping. The interior of the pump and piping must be thoroughly dried.
 - Inspect un-painted external steel or cast-iron surfaces once a month for moisture and replace volatile corrosion inhibitor at that time (see section 1.B.a.v)

EQUIPMENT PROTECTION

- Pumps

- Every 30 days, the pump and motor shaft should be rotated by hand (10-15 turns) to prevent bearing damage and potential for binding. Be sure shaft comes to rest in different positions.
- Close-coupled pumps may have minimal access to exposed shaft areas. In those cases, care must be taken to avoid damage to the shaft through use of channel-lock pliers or similar tools.
- If removal of the coupling guard is required for hand-rotation of the pump and motor shafts, this guarding must be reinstalled prior to removal of lock-out tag-out and start-up.
- Packaged Booster System Enclosures
 - Housing vents and/or openings will be sealed with plastic wrap and waterproof tape.
 - Condensation protection shall be provided in accordance to instructions previously noted.

PREPARATION FOR OPERATION

- Remove all rust inhibitor from exposed machined surfaces using the method described by the supplier.
- Remove all corrosion protection devices or material from package.
- Remove flange covers, tape, and all unnecessary pipe plugs.

3 Product Description

3.1 General description

Description

A pump station is a pre-engineered and fabricated line of packaged booster systems that provides:

- Energy efficiency
- System protection
- Hydraulic capability up to 2200 GPM
- Boost pressures up to 400 PSI

Intended applications



WARNING:

This product can expose you to chemicals including Lead, which is known to the State of California to cause cancer and birth defects or other reproductive harm. For more information go to: www.P65Warnings.ca.gov.

The pump station is intended for these applications:

- High rise buildings
- Industrial plants
- Municipal and rural water districts
- Agriculture / irrigation
- General water pressure boosting

3.1.1 Operational limits

Pressure

Pump system type	Max. discharge pressure
e-SVX Smart Pumps	400 PSI

3.2 Nameplate information

Important information for ordering

Every pump station has a nameplate that provides information about the pump station. The pump station nameplate is located on the inside of the control enclosure door.

When ordering spare parts, be prepared to identify the nameplate information when contacting the factory.

- Model
- Size
- Serial number
- Item numbers of the required parts.



Bell & Gossett www.xylem.com/bellgossett
a xylem brand

MODEL NUMBER

SERIAL NUMBER

VOLTS/PH/HZ

ENCL TYPE UL/NEMA

FLA

MAX HP

SCCR

STATION FLOW

PUMP BOOST

DATE CODE

Assembled in Auburn, NY, U.S.A. Part Number A01276C

EN

Nameplate field	Explanation
Model number	The manufacturer's number to indicate the particular type of product which has been acquired.
Serial number	A set of characters that uniquely identifies a single unit and can be used for traceability and warranty purposes.
Volts/PH/Hz	The rated voltage at which the station has been designed for. Should match the application site supply voltage.
ENCL TYPE UL/NEMA	Enclosure type
FLA	The full-load-ampere at which the station can operate.
Max HP	Rated HP
SCCR	"Short-Circuit Current rating". Represents the maximum level of short-circuit current that the assembly can withstand.
Station flow	The designed duty point, in GPM, LPH, etc.
Pump boost	The difference between the input side of the pump station and the output side of the pump station.
Date code	Marking of products to indicate their date of manufacture.

4 Installation

4.1 Reference manuals

Additional installation information

For information on e-SVX Smart Pumps and its installation, operation and maintenance:

- Refer the hydrovar X Smart Pump Range IOM (IM410) available in the Documentation & Tools section of the e-SVX product web page:



For information on hydrovar X programming and operation, use the following IOM:

- hydrovar X Programming IOM



For additional information on optimize programming and operation please visit www.xylem.com/optimize

For additional information on Avensor please visit <https://www.xylem.com/avensor>

4.2 Field connections

Diagrams

Actual equipment manufacturers/models installed are system specific. Refer to specific manufacturer Installation, Operation, and Maintenance manuals for details unique to each component.

Review the wiring diagrams and dimensional drawings before you install and operate the unit.

Electrical precautions



WARNING:

Electrical shock hazard. The electrical supply must match the control panel nameplate specification. Incorrect voltage can cause a fire, which damages the electrical components and voids the warranty. Failure to follow these instructions could result in serious personal injury or death, or property damage.

NOTICE:

Electrical connections must be made by certified electricians in compliance with all international, national, state, and local rules.

4.3 Ground (earth) and Power connections



WARNING:

Electrical shock hazard. Conduit grounds are not adequate. You must attach a separate ground (earth) wire to the ground (earth) lug provided in the enclosure in order to avoid potential safety hazards. Failure to follow these instructions can result in serious personal injury, death, or property damage.

A grounding terminal is provided for a dedicated ground (earth) wire connection. You must follow all provisions of the National Electrical Code and local codes.

All final installation power feed and earth wiring **SHALL** be done with **COPPER WIRE ONLY**. Failure to use copper wire could result in high resistance terminations and become a fire hazard.

EN

4.4 Packaged booster system location guidelines



WARNING:

Assembled units and their components are heavy. Failure to properly lift and support this equipment can result in serious physical injury and/or equipment damage. Lift equipment only at the specifically identified lifting points. Lifting devices such as eyebolts, slings, and spreaders must be rated, selected, and used for the entire load being lifted.

Guideline	Explanation/comment
Make sure that the space around the packaged booster system is sufficient.	This facilitates ventilation, inspection, maintenance, and service.
If you require lifting equipment such as a hoist or tackle, make sure that there is enough space above the packaged booster system.	This makes it easier to properly use the lifting equipment and safely remove and relocate the components to a safe location.
Use traditional lifting equipment (safety belt, sling, hooks, chains, etc.) to secure the assembly. Slots in the baseplate are provided for lifting via such methods. Additional slots located along the sides of the baseplate are provided for lifting via forklift. See Figure 1 on page 14 for more details.	Prevention against overturning the package
Protect the unit from weather and water damage due to rain, flooding, and freezing temperatures.	This is applicable if nothing else is specified.
Do not install and operate the equipment in closed systems unless the system is constructed with properly-sized safety and control devices.	Acceptable devices: <ul style="list-style-type: none"> • Pressure relief valves • Compression tanks • Pressure controls • Temperature controls • Flow controls If the system does not include these devices, consult the engineer or architect in charge before you operate the pump.
Take into consideration the occurrence of abnormal noise and vibration.	The best pump location for noise and vibration absorption is on a concrete floor with subsoil underneath.

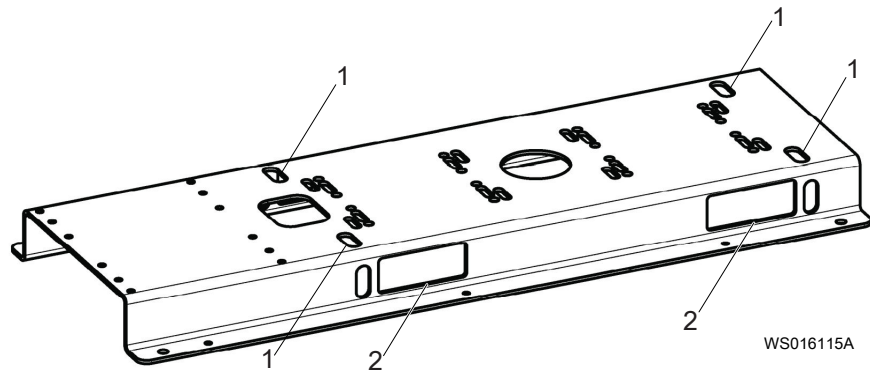

Figure 1: e-HVX Lifting Points

1. Lifting slots for slings, hooks, chains, etc.
2. Lifting slots for forklifts

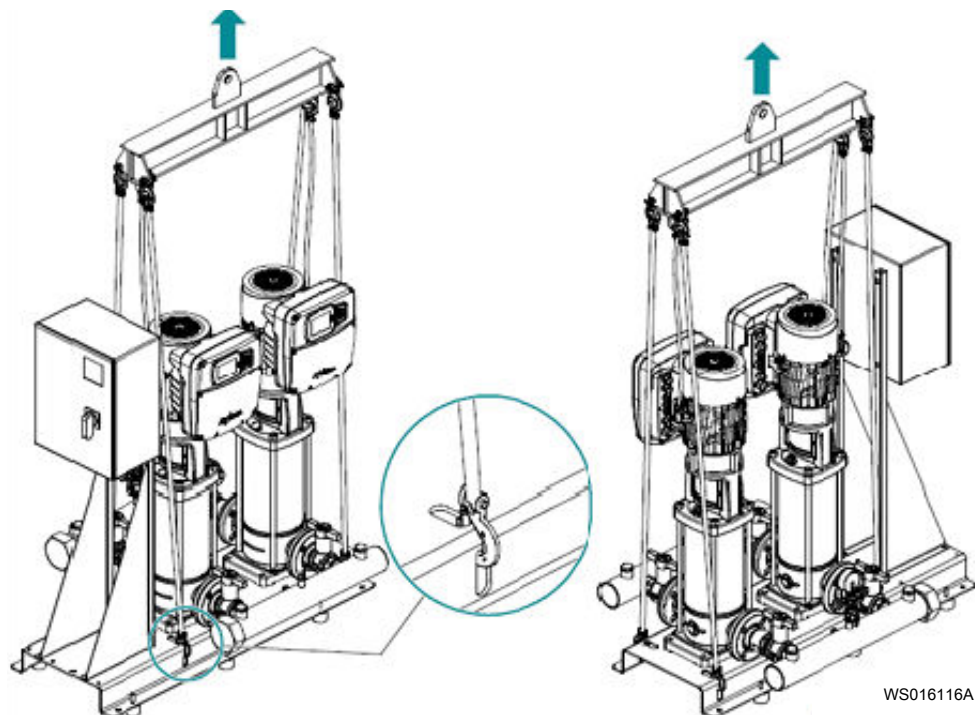

Figure 2: Rigging examples

4.5 Foundation requirements

Requirements

- The foundation must be able to absorb any type of vibration and form a permanent, rigid support for the unit.
- Provide a flat, substantial concrete foundation in order to prevent strain and distortion when you tighten the foundation bolts.

4.6 Level the base on a concrete foundation

Place 1" (25.40 mm) thick steel shims or wedges on both sides of each anchor bolt in order to support the pump.

This also provides a means of leveling the base.

4.7 Grout the baseplate

Required equipment:

- Cleaners: Do not use an oil-based cleaner because the grout will not bond to it. See the instructions provided by the grout manufacturer.
 - Grout: Non-shrink grout is recommended.
1. Clean all the areas of the baseplate that will come into contact with the grout.
 2. Build a dam around the foundation.
 3. Thoroughly wet the foundation that will come into contact with the grout.
 4. Pour grout around the baseplate.
To hold wedges or shims in place, allow the grout to flow around them.
Follow grout manufacturer's instructions for removing air pockets from grout during pour.
 5. Allow the grout to set.
The grout needs to set for at least 48 hours. Follow any additional instructions from the grout manufacturer.
 6. Tighten the foundation bolts.

EN

4.8 Piping checklist



WARNING:

- Avoid serious personal injury and property damage. Make sure that the flange bolts are adequately torqued.
-

NOTICE:

Never force piping to make a connection with a pump.

Check	Explanation/comment	Checked
Check that the suction and discharge pipes are supported independently by use of pipe hangers near the pump.	This eliminates pipe strain on the pump.	
Check that there is a strong, rigid support for the suction and discharge lines.	As a rule, ordinary wire or band hangers are not adequate to maintain proper alignment.	
Check that the suction or discharge lines are not forced into position.	Forcing these lines into position can cause misalignment of sealing gaskets and lead to leaks, or can crack flanges leading to severe mechanical failure and property damage.	
Check that fittings for absorbing expansion are installed in the system when considerable temperature changes are expected.	This helps to avoid strain on the pump.	

4.9 Xylem App setup

Introduction

Available for mobile devices with wireless technology operating system.

Use the App to:

- Check the status of the unit
- Configure parameters
- Interact with the unit and obtain data during installation and maintenance

- Generate a work report
- Contact the assistance service.

Download the App and connect the mobile device with the unit

1. Download the Xylem X App to the mobile device from App Store¹ or Google Play² by scanning the QR code:



2. Complete the registration.
3. On the drive display, press the wireless communication button.
4. Add the unit to the user profile.
5. When the connection has been established, the connection light turns steady blue. It is now possible to control the unit using the mobile device.

¹ Compatible with iOS® operating systems with version 15.0 and above.

² Compatible with Android operating system with version 10.0 and above.

5 Commissioning, Startup, Operation, and Shutdown

5.1 Preparation for startup



WARNING:

- Failure to follow these precautions before you start the unit will lead to serious personal injury and equipment failure.
- DO NOT operate the pump below the minimum rated flows or with the discharge valves closed. These conditions can create an explosive hazard due to vaporization of pumped fluid and can quickly lead to pump failure and physical injury.
- Always disconnect and lock out power to the driver before you perform any installation or maintenance tasks. Failure to disconnect and lock out driver power will result in serious physical injury.

NOTICE:

- Verify the driver settings before you start any pump.

You must follow these precautions before you start the pump:

- Flush and clear the system thoroughly to remove dirt or debris in the pipe system in order to prevent premature failure at initial startup.

5.1.1 Prestartup checklist



CAUTION:

Risk of leaks or flooding. Make sure to reinstall the drain plugs properly. Check all joints for tightness and flange bolts for the proper torque.

Checks	Checked
Check that the drain plugs are installed before filling system.	
Inspect all piping joints for tightness. Joints can become loose during transit due to vibration and shock.	
Check all flanged joints for the proper torque.	
Check that the system is full of liquid.	
Check that all high points in the piping system are vented in order to remove trapped air.	
Check that all pumps and drivers are properly lubricated.	
Check that the piping is clean and has been flushed.	

5.1.2 Final installation checks

Installation checklist



CAUTION:

Serious damage to the pump may result if it is started dry. Make sure that the pump is completely filled with liquid before it is started.

5.1.3 Final adjustments

Make the final adjustments on these adjustable devices in order to match the exact system requirements.

Thermal relief valve

An **optional** thermal relief valve is installed on the pump discharge in order to prevent potentially dangerous thermal pressure buildup. The valve automatically opens on a temperature increase and closes on a temperature decrease. This valve acts as a safety device; do not remove or plug it. It is factory set to open and discharge when the water temperature in the discharge header reaches between 125°F to 135°F (51°C to 57°C). Make sure that the 1/2 in. NPT opening of this valve assembly is piped to a floor drain in accordance with local codes.

After long periods of operation, the valve seat and disc can become worn or pitted. This allows leaks through the valve in the closed position. You can replace internal parts, if desired.

Low suction pressure switch

Adjust the setting to 10 psi below the rated suction pressure.

5.2 Pump station startup

5.2.1 Confirm the job site voltage

1. Check these items before you apply power or close the disconnect:
 - a) Check all of the power wiring connections and secure them as required.
 - b) Confirm with the owner/installing contractor if there are plans for any required building automation or remote connections.
 - c) Inspect and/or install any customer remote terminations.
2. Make note of the design data supplied on the data label. The label is located on the inside of the control panel door.
3. Use a volt meter to check the voltage on the incoming power terminals at the disconnect.
4. Compare the voltage to the data on the nameplate.

5.2.2 Connect the expansion tank



DANGER:

Explosion hazard. Prevent tank explosion. Do not install the tank when the system shut-off pressure exceeds the tank pressure rating.



DANGER:

Explosion hazard. Prevent tank explosion. Install a pressure relief valve on the tank inlet with a set point no greater than tank rating.

1. Precharge the expansion tank before you connect it to the system.

The air precharge needs to be 5 to 10 psi less than the system operating pressure.
2. If the expansion tank has already been installed and not precharged, then disconnect the system piping from the tank and equalize it to atmospheric pressure. If an isolation valve and drain are provided, then use them.
3. Apply air pressure to the tank through the air charging valve and pressurize to field conditions.

This needs to be equal to the NFSD restart pressure of 5 to 10 psi below the operating pressure.
4. Reconnect the tank to the system piping. Tank should be installed on the discharge side of the system.

5.2.3 Filling and priming

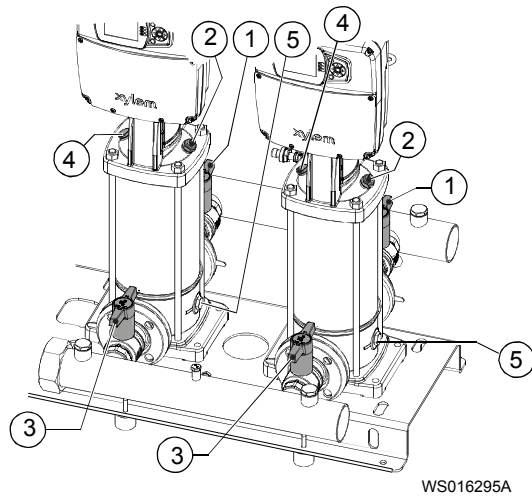

1. On-off valve on discharge line
2. Filler cap and vent plug
3. On-off valve on suction line
4. Fill plug
5. Drain plug

A. Positive suction head installation

1. Shut off the suction and discharge on-off valves for all pumps within the pump system.
2. For 5SVX models only, loosen the drain plug screw.
3. Loosen the vent plug and the fill plug.
4. Slowly open the suction valve until liquid regularly exits the vent plug of the pump; if necessary, continue loosening the valve.
5. Tighten the drain plug.
6. Tighten the vent plug.
7. Repeat steps 2-6 for all pumps within the pump system.
8. Slowly open the discharge on-off valve until fully open.

B. Suction lift installation

1. Open the suction on-off valve and close the discharge valve of all pumps within the pump system.
2. For 5SVX models only, loosen the drain plug screw.
3. Remove the filler cap.
4. Fill the pump.
5. For 5SVX models only, tighten the drain plug.
6. Close the filler cap.
7. Repeat steps 2 to 6 for each pump in the pump system.
8. Slowly open the on-off discharge valve until fully open.

5.2.4 Power the packaged booster system

1. Ensure the pump system is primed per the instruction of section [Filling and priming](#) on page 19.
2. Close the disconnect to apply power to the packaged booster system.
3. Turn the panel switch to the locked position.
4. Check that all hydrovar X displays are illuminated indicating receipt of power.
5. If the unit starts, press the power button located on the hydrovar X unit to stop the unit.

5.2.5 Configure the package system using the startup Genie

1. Follow the on-screen instructions of any hydrovarX unit to initiate the startup Genie.

Note:

- a) If the Genie is accidentally bypassed, use the multifunction button located on the lower left of the hydrovar X keypad to enter settings menu.
- b) If prompted, enter the default password (066).
- c) Navigate to the "General Settings" menu and select "Commissioning Complete" and set to "No".
- d) Power cycle the unit by opening and closing the electrical panel disconnect.
- e) Upon startup, the option to initialize the Genie will reappear.

Note:

- a) Refer to the hydrovar X programming manual for definitions of terms and settings. Alternatively, term definitions can be read within the hydrovar X unit by finding desired setting and pressing the right arrow key on the keypad until the definition is displayed.

Note:

- a) A factory restore will also reinitialize the start-up Genie following a power cycle.
 - b) To factory restore the hydrovar X unit, set the value of "Factory Restore" within the general settings to "Yes" and power cycle the unit.
2. Follow the on-screen instructions provided by the Genie to configure the unit to the desired application. Refer to the hydrovar X programming manual for more details and advanced setup options.
 3. Adjust any other settings in order to meet the needs of your system. Refer the hydrovar X programming IOM for more details on adjusting the drive settings.

5.2.6 Startup

Note all pumps should be powered but not running prior to the following steps. Perform the following steps for each pump within the pump system one at a time.

1. Close the discharge valve almost completely.
2. Fully open the suction on-off valve if closed.
3. Start the pump by pressing the "ON/OFF" button located on the hydrovar X unit to the right of its display.
4. Slowly open the discharge on-off valve until it is half open.
5. Wait a few minutes before fully opening the discharge on-off valve.
6. Stop the electric pump by pressing the "ON/OFF" button located to the right of the hydrovar X display.
7. Repeat steps 1-6 for each pump within the pump system.
8. Start all pumps within the pump system by pressing the "ON/OFF" button located to the right of the hydrovar X display.

5.2.7 Test the packaged booster system

1. Exit the setup menu.
2. If the packaged booster system is running, stop the system.
3. Provide a source of demand for the pump system such as a water faucet within the building being served by the packaged booster.
4. Press the power button on the master (lead) pump unit if operating in serial cascade mode to turn on the packaged booster system.
5. Observe the pressures and temperatures for normal operation.
6. Close any sources of demand for the pump system such as running water faucets to test a no-demand (no flow) condition.

It is assumed that no demand for water is required. For example, no flow.

7. Observe the No Flow Shutdown sequence. All minimum run timers must elapse for this sequence to occur.
8. Demand water from the system and observe the restart of the packaged booster system.

5.2.8 Final checks

Once the pump system has been tested and in operation, check the following:

1. No liquid is leaking from the pump set or pipes.
2. The maximum pressure of the pump set at the discharge, determined by the available suction pressure, is lower than the maximum pressure rating of the individual pump unit as indicated on the pump nameplate.
3. The pressure indicated within the hydrovar X display is the same as that of the discharge pressure gauge located on the discharge manifold of the pump system.
4. There is no unwanted noise or vibrations.
5. No vortices can occur at the end of the suction pipe, at the point of the foot check valve.
6. The low-pressure protection is working correctly.
7. When the main discharge valve is closed (zero flow), the pump system stops automatically.
8. After starting the system, run the pump system for several minutes with several sources of demand open to flush the system.

If the pump system does not deliver the required pressure, repeat steps outlined in sections [Connect the expansion tank](#) on page 18 and [Filling and priming](#) on page 19

5.2.9 Manual Stop

To manually stop the system, press the "ON/OFF" button located on the drive or open the main disconnect switch located on the system's electrical panel.

6 Maintenance

6.1 Precautions



DANGER:

Electrical hazard sufficient to kill. Always disconnect and lock out the power before you service the unit.



WARNING:

- This manual clearly identifies accepted methods for disassembling units. These methods must be adhered to. Trapped liquid can rapidly expand and result in a violent explosion and injury. Never apply heat to impellers, propellers, or their retaining devices to aid in their removal.
 - Make sure that each pump and the package are isolated from the system and that pressure is relieved before you disassemble the pump, remove plugs, open vent or drain valves, or disconnect the package piping.
 - Always disconnect and lock out power to the package and the driver before you perform any installation or maintenance tasks. Failure to disconnect and lock out driver power will result in serious physical injury.
 - Crush hazard. The unit and the components can be heavy. Use proper lifting methods and wear steel-toed shoes at all times.
-

6.2 Maintenance

6.2.1 Monthly maintenance

Sound and visual checks of the whole station

- Listen for any odd sounds that rub or grind, electrical arcing, and check for anything that is binding or unusual. These conditions can indicate a serious problem.
Note that there is going to be some harmonic vibration with the pumps and motor. Listen for excessive vibration or noise as this requires immediate service. Do not operate the pump if there is excessive vibration.
- Confirm that the building cooling and ventilation systems are operating and clear of all obstructions. The maximum operating range for equipment is 104°F (40°C).
- Verify that water, grease, oil, and hardware are not leaking or loose on the pump station.

Station skid

- Visually inspect for leaks in the station piping, valves, and other components.
- Visually inspect the piping and skid for any stress cracks in the welds.
- Visually inspect the station for loose or damaged paint or areas of rust.

6.2.2 Maintenance every 3 months

Check that the expansion tank is pre-charged correctly, see Section 5.2.2 for more information.

6.2.3 Maintenance every year, or 4000 hours of operation

1. Check the condition of any cables or conduit.
2. Re-tighten terminals within the control panel if necessary.
3. Ensure there are no signs of overheating and electric arcs on the terminal boxes.
4. Ensure there are no signs of humidity within the control panel and within each pump unit's hydrovar X drive.
5. Check the connection to ground.

-
6. Check the status/operation of any fuses or switches.
 7. Check the status of the main and local suction/discharge valves.
 8. Ensure all valves are able to fully close and open.
 9. Clean ventilation openings of the control panel if present.
 10. Clean the fan cover for each hydrovar X unit within the system. Fan covers are removable and secured in place by M4x10 capscrews.
 11. While cleaning the fan cover, check the status of the cooling fan for each hydrovar X unit.

EN

6.2.4 Maintenance every 2 years, or 10,000 hours of operation

Replace the mechanical seal for each e-SVX unit.

6.2.5 Maintenance every 5 years, or 17,500 hours of operation.

Replace the motor bearings. Motor bearings are greased for life with a Polymer 400 grease. Motor bearing types and sizes are indicated on the hydrovar X motor nameplate.

7 Troubleshooting

7.1 Pump station troubleshooting

DANGER:

- Personal injury hazard. Troubleshooting a live control panel exposes personnel to hazardous voltages. Electrical troubleshooting must be done by a qualified electrician. Failure to follow these instructions will result in serious personal injury, death, and/or property damage.
- Electrical hazard sufficient to kill. Always disconnect and lock out the power before you service the unit.

WARNING:

Electrical connections must be made by certified electricians in compliance with all international, national, state, and local rules.

Note that some troubleshooting procedures apply to only constant speed systems or only variable speed systems.

Use these Installation, Operation, and Maintenance manuals for more information:

- B&G hydrovar X Smart Pump Range IOM (P2006078)
- hydrovar X Programming IOM

7.1.1 The pump station does not power up

Cause	Remedy
The site voltage does not match the pump station voltage.	Make sure that the site voltage matches the pump station design voltage.
Line-to-line voltage is not balanced.	Check incoming voltage and amperage. Line-to-line voltage should be balanced. Line-to-ground voltage should also be balanced.
The power fuses are blown or breakers are tripped.	Check power fuses and breakers. Breakers are shipped in the OFF position. Replace blown fuses.
The pump station is not properly grounded (earthed).	Check that proper grounding (earthing) techniques have been used for the pump station.
There is a fault.	Check for fault codes or fault lights Correct the fault.

7.1.2 The station powers up, but the pumps do not run

Cause	Remedy
hydrovar X units are turned off	Press the power button on the hydrovar X unit to run the system
The desired pressure is satisfied.	Check to see if the desired pressure is satisfied. If the actual pressure is greater than the set point pressure, then the pumps are automatically stopped.
There is a fault.	Check for fault codes and error messages within the hydrovar X unit display. Refer to the hydrovar X Programming IOM manual for error code details and remedies.

Cause	Remedy
The fuses are blown or breakers are tripped.	Check circuit breaker and fuses.
Transducer isolation valves are closed.	Make sure that the transducer isolation valves are in the open position.
The impeller is bound.	Check to see if you can turn the pump by hand. Check for a bound impeller.
A pressure transducer is faulty.	Replace faulty pressure transducers.
Motor is defective.	Repair or replace motor.

7.1.3 The pumps run but do not build desired pressure

Cause	Remedy
Pumps are running off their design curve.	Check the application. Is the system running in an open discharge condition (excessive flow rate)? For example, is the system filling a large irrigation line for the first time of the season?
Pumps are running at less than full speed.	Check to see if the pumps are running at full speed. If they are running less than full speed, they could be experiencing electrical issues. Check the panel for power status.
The inlet pressure does not match the project specifications.	Check to see if the inlet pressure matches the project specifications. Variations in inlet pressure can have detrimental effects on performance.
A pipe is broken.	Check for broken pipes.
The transducer isolation valves are closed.	Check to be sure that the transducer isolation valves are in the open position.
The NPSH is insufficient.	Check the NPSH. Are proper flooded conditions or positive pressure being delivered to the pump station? Check for air in the supply lines. Check for properly filled supply tanks (if applicable). Excessive suction lift or piping losses will limit the life expectancy of the pumps.
The pump station has lost its prime.	Check to be sure that the pump station has been primed properly. Make sure that all pumps and components are properly filled with water.
A suction or discharge valve is closed or clogged.	Check the isolation valves and check valves. Are all suction/discharge valves open? Could any valves be plugged? Could the pumps be plugged?
The motor is not operating at the rated RPM.	Use the hydrovar X Programming IOM to ensure that the drive speed settings are correct for your system.
The impeller is worn or plugged.	Take the pump to an authorized pump repair facility.
The pump bearings are worn.	Take the pump to an authorized pump repair facility.

7.1.4 The pump station experiences excessive vibration

Cause	Remedy
The motor, pump, or piping is loose.	Make sure that all fasteners and components are properly tightened.
Foreign bodies inside the pump system	Contact Xylem or an authorized distributor, or send the pump system to an authorized workshop.

Cause	Remedy
Pumps are running off their design curve.	Check the application. Is the system running in an open discharge condition (excessive flow rate)? For example, is the system filling a large irrigation line for the first time of the season?
Air or gases are present in the pumped liquid.	Check water supply lines and tanks. Check for air or gases in liquid. Bleed the lines.
Discharge piping is plugged.	Check discharge piping/valves. Could the piping be plugged? Could the pump be plugged? Are the isolation valves open? Clear any clogs.
Supply piping has excessive suction/lift conditions or friction loss.	Check for excessive suction/lift conditions or friction loss on supply piping.
The impeller is bound or worn.	Take the pump to an authorized pump repair facility.
Pumps and pipes are not properly aligned.	Correct the alignment between pumps and pipes.
Cavitation	Check the suction conditions of the pump system and ensure they are met.
Pump tie rods are loose	Tighten tie rod nuts
Pump set faulty	Contact Xylem or an authorized distributor. Alternatively, send pump system to an authorized repair facility.

7.1.5 The pump station does not shut down and no water is used

Cause	Remedy
The system pressure is set beyond capability of the station.	Check the system set pressure. Is this duty point beyond the capability of the pump station?
There are leaks or broken pipes.	Check for broken pipes or leaks. Does the system pressure decrease if the pump station is turned off?
The diaphragm tank is faulty.	Check for a properly installed diaphragm tank. Has the tank failed? Has the tank been charged to the proper operating pressure before installation? (~10 psi below the desired set point)
The pressure transducers are faulty.	Check the pressure transducers. Does the actual mechanical gauge pressure match the pressure displayed on the VFDs and the PLC?
A check valve is malfunctioning.	Check for malfunctioning check valves. Does the system hold pressure when the pump package is shut down? Replace faulty valves.

7.1.6 The pump station cycles or hunts erratically

Cause	Remedy
The pumps are oversized for the current demand.	Check the application. Possibly increase the size of the bladder tank for low demand situations.
The inlet pressure is fluctuating.	
There are leaks or broken pipes.	Check for broken pipes or leaks. Does the system pressure decrease when the pump station is turned off?
The diaphragm tank is faulty.	Check for a properly installed diaphragm tank. Has the tank failed? Has the tank been charged to the proper operating pressure before installation? (~10 psi below the desired set point)

Cause	Remedy
The pressure transducers are faulty.	Check the pressure transducers. Does the actual mechanical gauge pressure match the pressure displayed on the VFDs.
A check valve is malfunctioning.	Check for malfunctioning check valves. Replace faulty valves.

7.1.7 The pump system does not stop when the setpoint is reached

Cause	Remedy
Check for blockages and clogs at the discharge valve	Replace the valve
Expansion tank is damaged, not installed, incorrectly sized, or pre-charged incorrectly	Install, replace or pre-charge the expansion vessel
Setpoint does not match the intended application	Reprogram the pressure setpoint for the master hydrovar X unit per the hydrovar X Programming IOM.

7.1.8 The pump is leaking at the mechanical seal

Cause	Remedy
Mechanical seal is damaged or worn	Contact Xylem or an authorized distributor, or send the pump system to an authorized repair facility.

7.1.9 The drive display does not turn on

Cause	Remedy
Main control panel switch set to OFF	Turn the switch to ON
The drive circuit breaker is set to OFF (open)	Turn ON (close) the circuit breaker
Power supply cord is damaged	Replace the cable
Pump system is faulty	Contact Xylem or an authorized distributor.
Electric supply is absent	Reset the power supply

7.1.10 The pump system runs at maximum speed without stopping

Cause	Remedy
Pressure setpoint is not suitable for the system. The setpoint is higher than the pump can deliver.	Adjust the setpoint according to the performance of the pump as indicated on the nameplate.
Pressure sensor is disconnected or damaged	Check the hydrovar X unit display for a missing pressure sensor error code. If present, reconnect the sensor or replace as required.

7.1.11 Only one pump of the multi-pump set is working

Cause	Remedy
Electric pumps do not share the same settings	Ensure the units are configured for serial cascade multi-pump control.
Serial connection between drives is faulty	Ensure RS485 communication cables are wired correctly into the hydrovar X unit terminal blocks and that there is no cable damage present.

7.1.12 The pump does not start when there is liquid demand

Cause	Remedy
The setpoint is set to zero.	Check the drive settings and adjust the setpoint to the system requirement.
The float switch is open.	The float switch is faulty and should be replaced or check the level of liquid in the tank.
The minimum pressure switch is open.	Check: The pressure switch and replace if faulty, there is sufficient suction-side pressure, the connection of the switch, the switch calibration is correct.
Pressure transducers are plugged, obstructed, or faulty.	Check for debris in the transducer measuring orifice, gently remove any debris using a toothpick or forced air. Verify that transducer isolation valves are open before and after inspection/cleaning.

7.1.13 hydrovar X unit error or alarm

Cause	Remedy
Miscellaneous	See the hydrovar X programming manual for a list of errors, alarms, and solutions.

8 Product Nomenclature

8.1 Pump station numbering system

EN

The pump station label located on the inside of the control enclosure door identifies the product code number for the various versions of the pump systems. This number is also the catalog number for the pump station. The pump station numbering systems describe the meaning of each digit.

Not all combinations are possible.

8.1.1 Pump station with e-SV pumps

Example product code for e-HVX (5-15SVX)

HVX	3	D	3	R	-	5SVX11G1AXX0	-	BG
-----	---	---	---	---	---	--------------	---	----

Example product code for e-HVX (33-125SVX)

HVX	2	D	4	L	-	33SVX1GHAXX0	-	BG
-----	---	---	---	---	---	--------------	---	----

Example product code for e-HVXR (5-15SVX)

HVXR	3	D	3	R	-	5SVX11R1AXX0	-	BG
------	---	---	---	---	---	--------------	---	----

Numbering system definitions

First character: Variable or constant speed	
HVX = e-HVX	
HVXR = e-HVXR	

Second character: Number of pumps	
2 = Duplex	
3 = Triplex	

Third character: Supply voltage	
D = 380-480 V / 3 PH (460 V Nominal)	
L = 200-240 V / 3 PH (230 V Nominal)	

Fourth character: Header size	
2 = 2 in.	6 = 6 in.
3 = 3 in.	8 = 8 in.
4 = 4 in.	1 = 10 in.

Fifth character: Panel orientation	
R = Right	
L = Left	

Sixth character: e-SVX Part Number	
See e-SVX Nomenclature	

Seventh character: Brand	
BG	B&G

NOTICE:

Please note not all e-SVX configurations are available for e-HVX and e-HVXR booster package systems. Refer to the product technical brochure for a list of valid combinations.

EN

Nomenclature - 1-22SVX

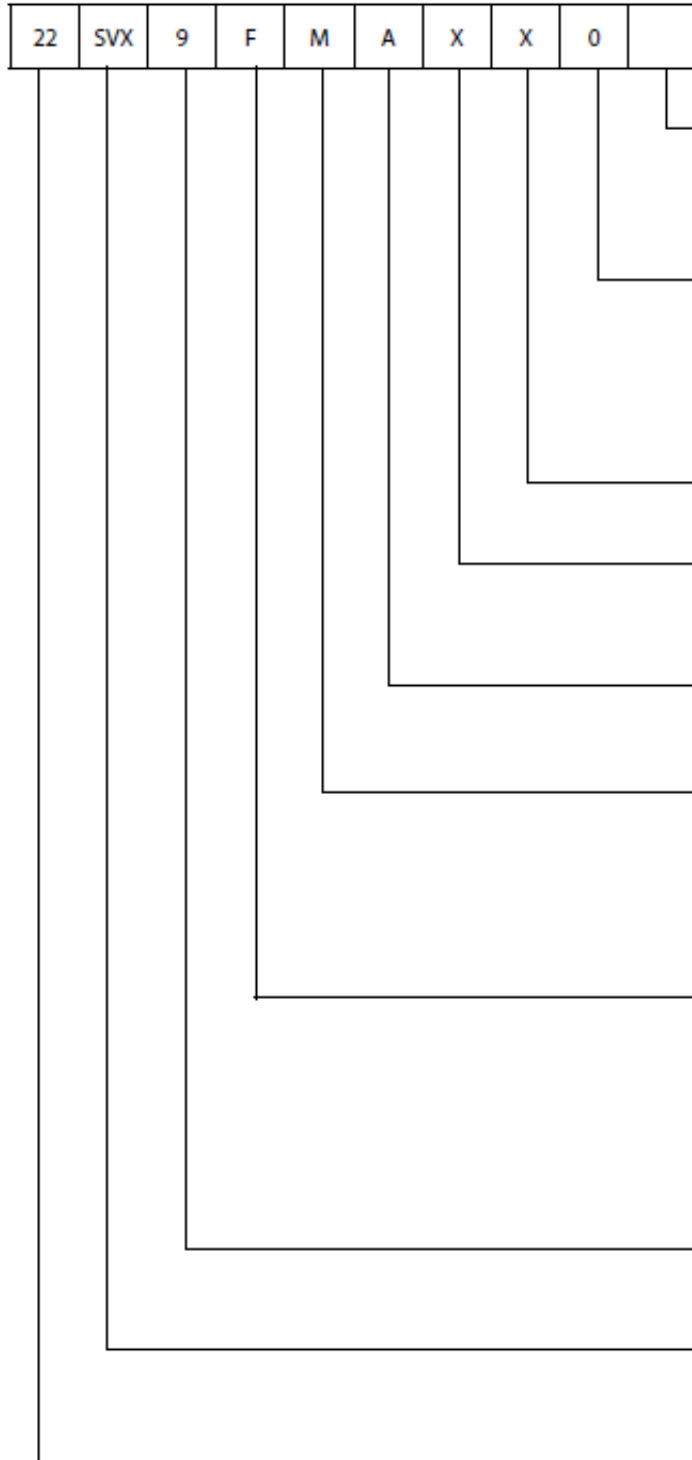

Each e-SVX pump is identified by a product code on the pump label. Each digit in the code is described below. The product code is also the catalog number for the pump. Note: Not all combinations are possible.

EN

Special Configurations (1-2 Characters)

- [P] = Passivization only
- [S] = Customized configuration
- [Z] = High Pressure

Seal Materials (1 Character)

- [0] = Carbon/SilCar/FKM
- [1] = Carbon/SilCar/AFLAS (High Temp)
- [2] = SilCar/SilCar/FKM
- [4] = SilCar/SilCar/EPR
- [6] = Carbon/SilCar/EPR

hydrovar X Version (1 Character)

- [X] = standard hydrovar X

Voltage (1 Character)

- [L] = 200-240V
- [X] = 380-480V

Pole-Hz-Phase (1 Character)

- [A] = 4-60-3 (1200-3600)

Motor HP (1 Character)

- [1] = 4 HP [L] = 20 HP
- [2] = 5.5 HP [M] = 25 HP
- [H] = 7.5 HP [N] = 30 HP
- [J] = 10 HP
- [K] = 15 HP

Configuration Option (1 Character)

- | | |
|--|---|
| <ul style="list-style-type: none"> [C] = Clamp 316 [F] = Round-304 (SVB) [G] = Cl-304 [N] = Round-316 (SVD) [P] = Victaulic-316 [T] = Oval-304 (SVA) | <p>Bottom & Top Location:</p> <ul style="list-style-type: none"> [R] = (SVC) 12Suct - 12Disch [W] = (SVC) 12Suct - 03Disch [X] = (SVC) 12Suct - 06Disch |
|--|---|

Number of stages (1-2 Characters)

Omit special characters such as 'I' and do not include 0 for single digit staging (i.e. 2 not 02).

Product Line (3 Characters)

[SVX] = e-SV stainless vertical multistage pump with hydrovar X

Nominal Flow (1-3 Characters)

- [1] = 5 GPM
- [3] = 16 GPM
- [5] = 26 GPM
- [10] = 53 GPM
- [15] = 80 GPM
- [22] = 116 GPM

* For CE compliant 50 Hz motors, please contact the factory

WS016123A

Figure 3: 1-22SVX

Nomenclature - 33-125SVX

Example Product Code (33-125 e-SVX)*

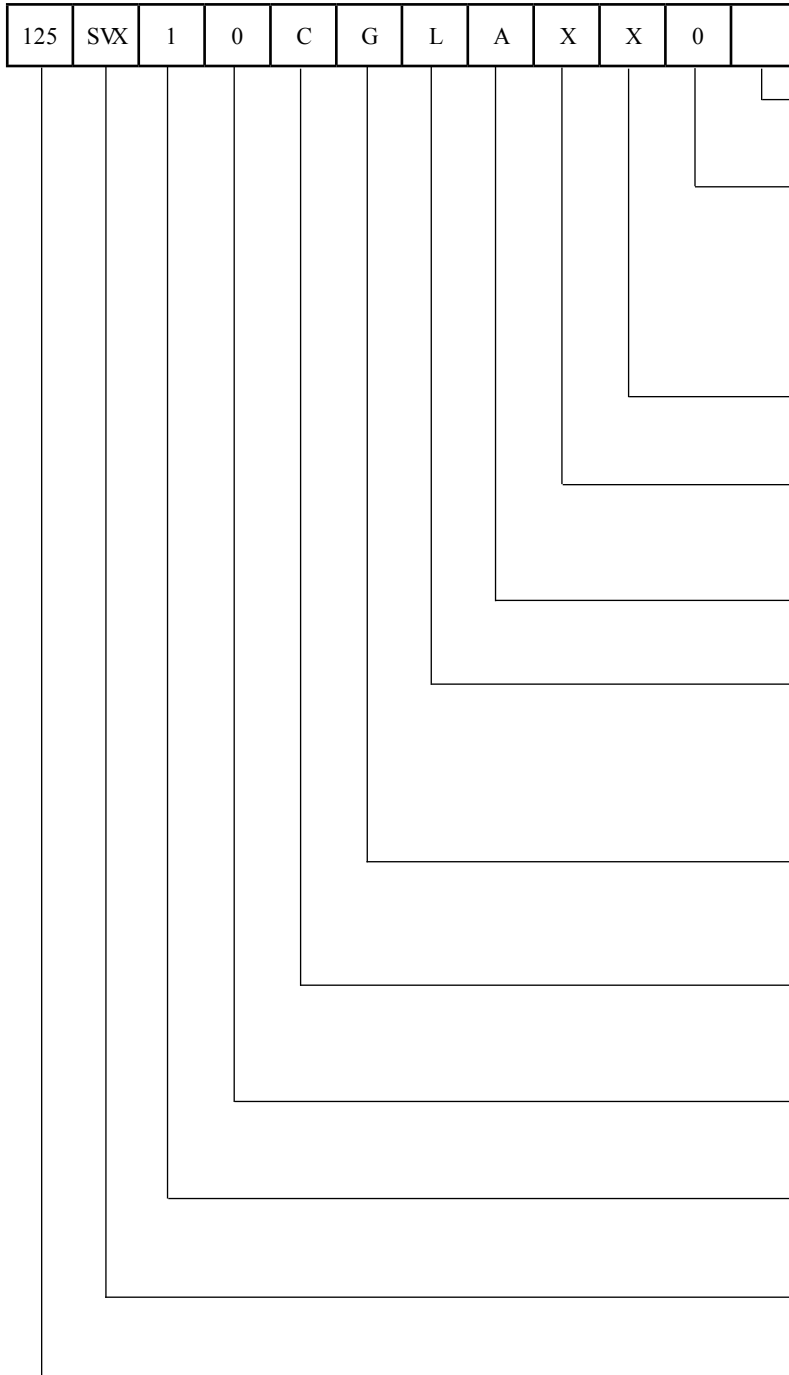

Special Configurations (1-2 Characters)

[P] = Passivation only
 [S] = Customized configuration
 [Z] = High Pressure (250/300 psi pump body)

Seal Materials (1 Character)

[0] = Carbon/SilCar/FKM
 [1] = Carbon/SilCar/AFLAS (High Temp)
 [2] = SilCar/SilCar/FKM
 [4] = SilCar/SilCar/EPR
 [6] = Carbon/SilCar/EPR

hydrovar X Version (1 Character)

[X] = standard hydrovar X

Voltage (1 Character)

[L] = 200-240V
 [X] = 380-480V

Pole-Hz-Phase (1 Character)

[A] = 4-60-3 (1200-3600 RPM)

Motor HP (1 Character)

[1] = 4 HP [K] = 15 HP
 [2] = 5.5 HP [L] = 20 HP
 [H] = 7.5 HP [M] = 25 HP
 [J] = 10 HP [N] = 30 HP

Configuration Option (1 Character)

[G] = Round-CI-304
 [N] = Round-316

125SV ONLY (1 Character)

Reduced Trim Diameter C = 145 mm (full dia.) option, only. Blank if 33-92SV

Number of reduced trim impellers (1 Character)

The number of reduced trim impellers. If no reduced trim impellers are used, insert "0".

Total Number of Impeller Stages (may be 1 or 2 characters)

Do not include 0 for single digit staging (i.e. 2, not 02).

Product Line (3 Characters)

[SVX] = e-SV stainless vertical multistage pump with hydrovar X

Nominal Flow (1-3 Characters)

[33] = 175 GPM
 [46] = 240 GPM
 [66] = 350 GPM
 [92] = 485 GPM
 [125] = 660 GPM

WS016124A

Other product code examples:

- Example (1-22SVX with special configuration): 1SVX30G1AXX0P
- Example (33-92SVX with no reduced trim impellers): 46SVX10GHAXX0
- Example (33-92SVX with reduced trim impellers): 46SVX21GKAXX0
- Example (125SVX with no reduced trim impellers, with reduced trim diameter): 125SVX10CNLAXX1

* For CE compliant 50 Hz motors, please contact the factory

9 Appendix

9.1 Installation drawings

EN

Duplex (200-240/3 and 380-480/3 Volt): 5SVX to 15SVX4

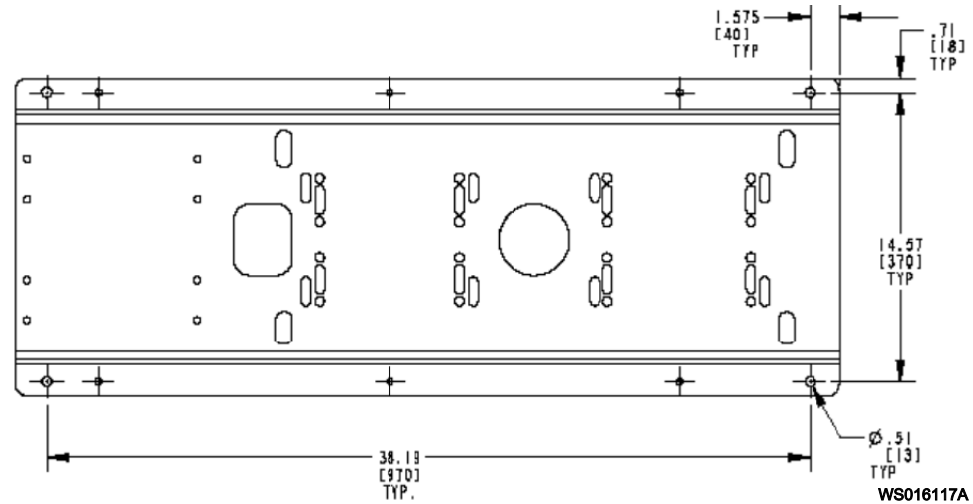

Duplex (200-240/3 and 380-480/3 Volt): 15SVX7 to 92SVX

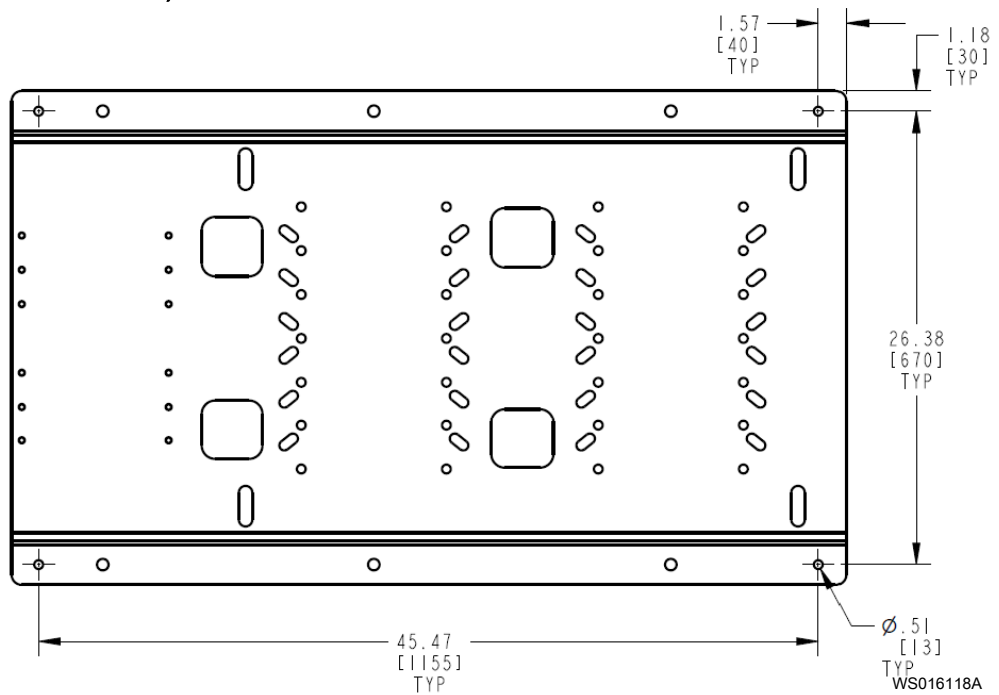

Duplex (380-480/3 Volt): 125SVX

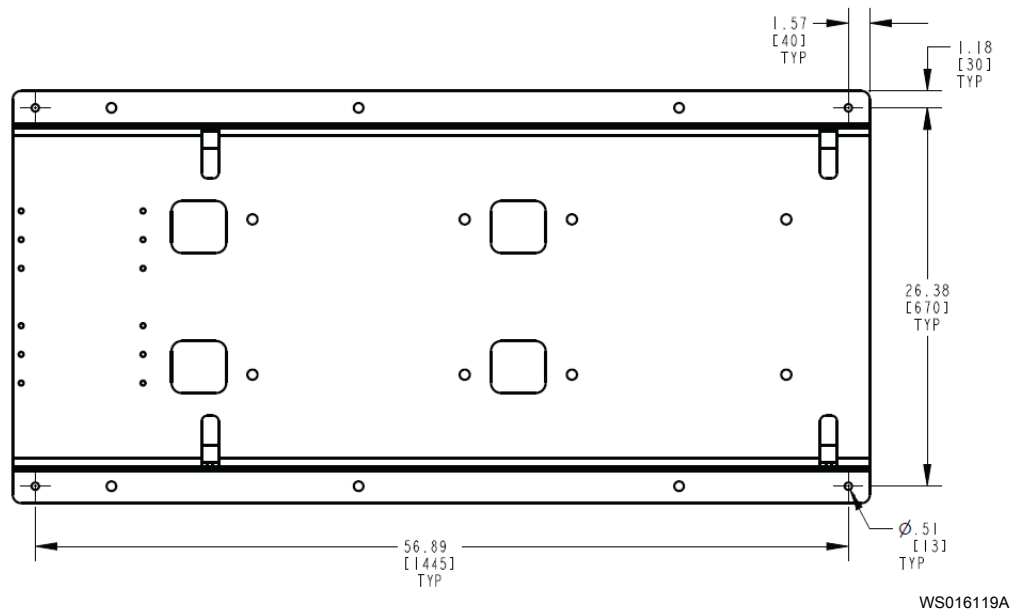

Triplex (200-240/3 and 380-480/3 Volt): 5SVX to 15SVX4

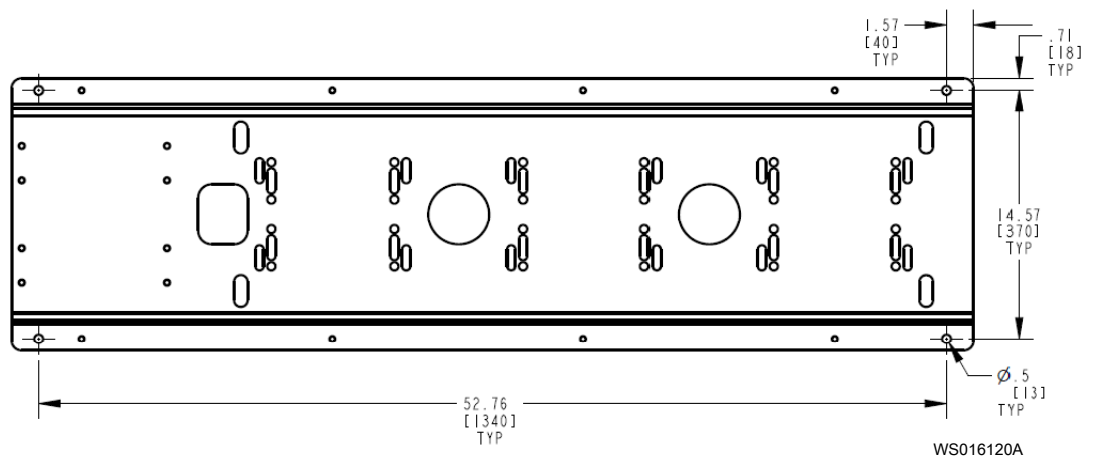

Triplex (200-240/3 and 380-480/3 Volt): 15SVX7 to 92SVX

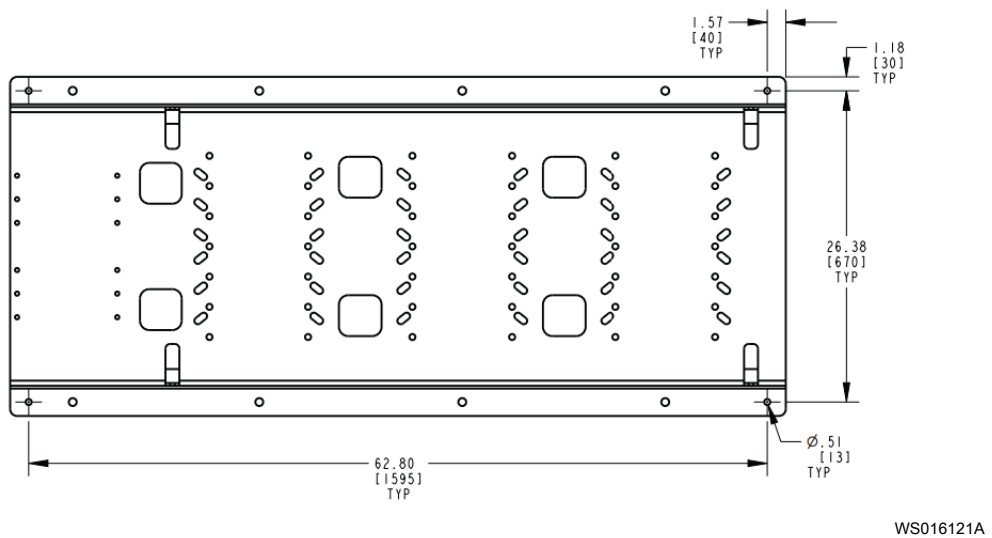

Triplex (380-480/3 Volt): 125SVX

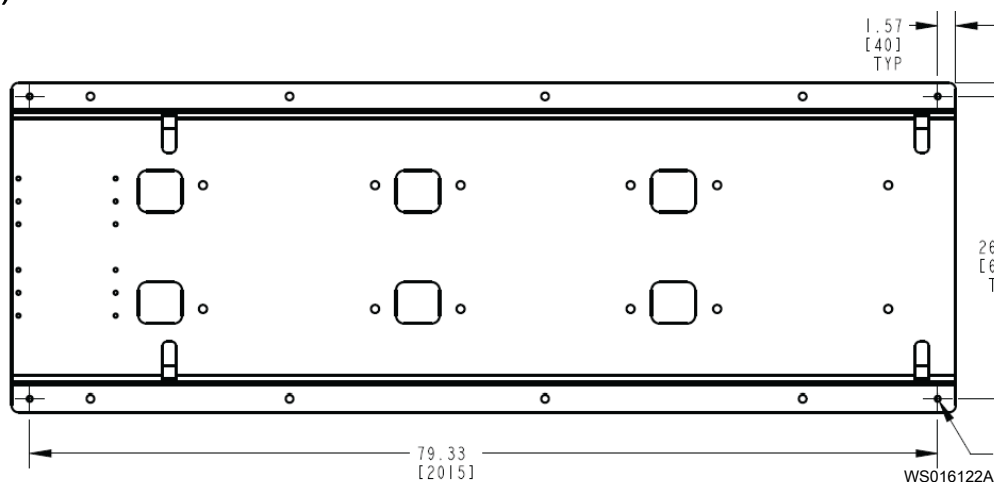

EN

9.2 Sound pressure

Measured in free field at a distance of one meter (3.28 ft) from the pump set operating at 3600 RPM without load.

Size	Frame	HP	LpA, dB +/- 2
B	143-145	4-7.5	< 75
C	213-215	7.5-15	< 82
D	254-256	15-30	< 82

9.3 Dimensions and weights

For motor-specific dimensional and weight data, refer to the hydrovar X motor specifications documents where motor drawings are available by speed range, voltage rating, power rating, frame type, and frame size. To understand the motor-pump pairing for a given product and its associated technical data, consult the product-specific technical brochure.

Motor Type	Voltage Range	Power (hp)	Motor Frame	Specification Document Number	
EXM56/4.040BH2	380-480V	4	56	XY-hyXeXM-SUB-520	
EXM143-145/4.040BH2		4	143-145	XY-hyXeXM-SUB-521	
EXM143-145/4.055BH2		5.5	143-145	XY-hyXeXM-SUB-522	
EXM143-145/4.075BH2		7.5	143-145	XY-hyXeXM-SUB-523	
EXM213-215/4.075CH2		7.5	213-215	XY-hyXeXM-SUB-524	
EXM213-215/4.100CH2		10	213-215	XY-hyXeXM-SUB-525	
EXM213-215/4.150CH2		15	213-215	XY-hyXeXM-SUB-526	
EXM254-256/4.150DH2		15	254-256	XY-hyXeXM-SUB-527	
EXM254-256/4.200DH2		20	254-256	XY-hyXeXM-SUB-528	
EXM254-256/4.250DH2		25	254-256	XY-hyXeXM-SUB-529	
EXM254-256/4.300DH2		30	254-256	XY-hyXeXM-SUB-530	
EXM90HMHB/4.040BH2		200-240V	4	90	XY-hyXeXM-SUB-531
EXM100HMHC/4.055BH2			5.5	100	XY-hyXeXM-SUB-533
EXM112HMHC/4.075BH2			7.5	112	XY-hyXeXM-SUB-534
EXM56/4.040BH2	4		56	XY-hyXeXM-SUB-520	
EXM143-145/3.040BH2	4		143-145	XY-hyXeXM-SUB-536	

Motor Type	Voltage Range	Power (hp)	Motor Frame	Specification Document Number
EXM213-215/3.075CH2		7.5	213-215	XY-hyXeXM-SUB-537
EXM254-256/3.150DH2		15	254-256	XY-hyXeXM-SUB-538
EXM254-256/3.200DH2		20	254-256	XY-hyXeXM-SUB-539
EXM90HMHB/3.040BH2		4	90	XY-hyXeXM-SUB-540

EN

10 Product Warranty

Commercial warranty

EN

Warranty. For goods sold to commercial buyers, Seller warrants the goods sold to Buyer hereunder (with the exception of membranes, seals, gaskets, elastomer materials, coatings and other "wear parts" or consumables all of which are not warranted except as otherwise provided in the quotation or sales form) will be (i) be built in accordance with the specifications referred to in the quotation or sales form, if such specifications are expressly made a part of this Agreement, and (ii) free from defects in material and workmanship for a period of from the date of installation or from the date of shipment (which date of shipment shall not be greater than after receipt of notice that the goods are ready to ship), whichever shall occur first, unless a longer period is specified in the product documentation (the "Warranty").

Except as otherwise required by law, Seller shall, at its option and at no cost to Buyer, either repair or replace any product which fails to conform with the Warranty provided Buyer gives written notice to Seller of any defects in material or workmanship within ten (10) days of the date when any defects or non-conformance are first manifest. Under either repair or replacement option, Seller shall not be obligated to remove or pay for the removal of the defective product or install or pay for the installation of the replaced or repaired product and Buyer shall be responsible for all other costs, including, but not limited to, service costs, shipping fees and expenses. Seller shall have sole discretion as to the method or means of repair or replacement. Buyer's failure to comply with Seller's repair or replacement directions shall terminate Seller's obligations under this Warranty and render the Warranty void. Any parts repaired or replaced under the Warranty are warranted only for the balance of the warranty period on the parts that were repaired or replaced. Seller shall have no warranty obligations to Buyer with respect to any product or parts of a product that have been: (a) repaired by third parties other than Seller or without Seller's written approval; (b) subject to misuse, misapplication, neglect, alteration, accident, or physical damage; (c) used in a manner contrary to Seller's instructions for installation, operation and maintenance; (d) damaged from ordinary wear and tear, corrosion, or chemical attack; (e) damaged due to abnormal conditions, vibration, failure to properly prime, or operation without flow; (f) damaged due to a defective power supply or improper electrical protection; or (g) damaged resulting from the use of accessory equipment not sold or approved by Seller. In any case of products not manufactured by Seller, there is no warranty from Seller; however, Seller will extend to Buyer any warranty received from Seller's supplier of such products.

THE FOREGOING WARRANTY IS EXCLUSIVE AND IN LIEU OF ANY AND ALL OTHER EXPRESS OR IMPLIED WARRANTIES, GUARANTEES, CONDITIONS OR TERMS OF WHATEVER NATURE RELATING TO THE GOODS PROVIDED HEREUNDER, INCLUDING WITHOUT LIMITATION ANY IMPLIED WARRANTIES OF MERCHANTABILITY AND FITNESS FOR A PARTICULAR PURPOSE, WHICH ARE HEREBY EXPRESSLY DISCLAIMED AND EXCLUDED. EXCEPT AS OTHERWISE REQUIRED BY LAW, BUYER'S EXCLUSIVE REMEDY AND SELLER'S AGGREGATE LIABILITY FOR BREACH OF ANY OF THE FOREGOING WARRANTIES ARE LIMITED TO REPAIRING OR REPLACING THE PRODUCT AND SHALL IN ALL CASES BE LIMITED TO THE AMOUNT PAID BY THE BUYER FOR THE DEFECTIVE PRODUCT. IN NO EVENT SHALL SELLER BE LIABLE FOR ANY OTHER FORM OF DAMAGES, WHETHER DIRECT, INDIRECT, LIQUIDATED, INCIDENTAL, CONSEQUENTIAL, PUNITIVE, EXEMPLARY OR SPECIAL DAMAGES, INCLUDING BUT NOT LIMITED TO LOSS OF PROFIT, LOSS OF ANTICIPATED SAVINGS OR REVENUE, LOSS OF INCOME, LOSS OF BUSINESS, LOSS OF PRODUCTION, LOSS OF OPPORTUNITY OR LOSS OF REPUTATION.

Limited consumer warranty

Warranty. For goods sold for personal, family or household purposes, Seller warrants the goods purchased hereunder (with the exception of membranes, seals, gaskets, elastomer

materials, coatings and other "wear parts" or consumables all of which are not warranted except as otherwise provided in the quotation or sales form) will be free from defects in material and workmanship for a period of from the date of installation or from the product date code, whichever shall occur first, unless a longer period is provided by law or is specified in the product documentation (the "Warranty").

Except as otherwise required by law, Seller shall, at its option and at no cost to Buyer, either repair or replace any product which fails to conform with the Warranty provided Buyer gives written notice to Seller of any defects in material or workmanship within ten (10) days of the date when any defects or non-conformance are first manifest. Under either repair or replacement option, Seller shall not be obligated to remove or pay for the removal of the defective product or install or pay for the installation of the replaced or repaired product and Buyer shall be responsible for all other costs, including, but not limited to, service costs, shipping fees and expenses. Seller shall have sole discretion as to the method or means of repair or replacement. Buyer's failure to comply with Seller's repair or replacement directions shall terminate Seller's obligations under this Warranty and render this Warranty void. Any parts repaired or replaced under the Warranty are warranted only for the balance of the warranty period on the parts that were repaired or replaced. The Warranty is conditioned on Buyer giving written notice to Seller of any defects in material or workmanship of warranted goods within ten (10) days of the date when any defects are first manifest.

Seller shall have no warranty obligations to Buyer with respect to any product or parts of a product that have been: (a) repaired by third parties other than Seller or without Seller's written approval; (b) subject to misuse, misapplication, neglect, alteration, accident, or physical damage; (c) used in a manner contrary to Seller's instructions for installation, operation and maintenance; (d) damaged from ordinary wear and tear, corrosion, or chemical attack; (e) damaged due to abnormal conditions, vibration, failure to properly prime, or operation without flow; (f) damaged due to a defective power supply or improper electrical protection; or (g) damaged resulting from the use of accessory equipment not sold or approved by Seller. In any case of products not manufactured by Seller, there is no warranty from Seller; however, Seller will extend to Buyer any warranty received from Seller's supplier of such products.

THE FOREGOING WARRANTY IS PROVIDED IN PLACE OF ALL OTHER EXPRESS WARRANTIES. ALL IMPLIED WARRANTIES, INCLUDING BUT NOT LIMITED TO THE IMPLIED WARRANTIES OF MERCHANTABILITY AND FITNESS FOR A PARTICULAR PURPOSE, ARE LIMITED TO FROM THE DATE OF INSTALLATION OR FROM THE PRODUCT DATE CODE , WHICHEVER SHALL OCCUR FIRST. EXCEPT AS OTHERWISE REQUIRED BY LAW, BUYER'S EXCLUSIVE REMEDY AND SELLER'S AGGREGATE LIABILITY FOR BREACH OF ANY OF THE FOREGOING WARRANTIES ARE LIMITED TO REPAIRING OR REPLACING THE PRODUCT AND SHALL IN ALL CASES BE LIMITED TO THE AMOUNT PAID BY THE BUYER FOR THE DEFECTIVE PRODUCT. IN NO EVENT SHALL SELLER BE LIABLE FOR ANY OTHER FORM OF DAMAGES, WHETHER DIRECT, INDIRECT, LIQUIDATED, INCIDENTAL, CONSEQUENTIAL, PUNITIVE, EXEMPLARY OR SPECIAL DAMAGES, INCLUDING BUT NOT LIMITED TO LOSS OF PROFIT, LOSS OF ANTICIPATED SAVINGS OR REVENUE, LOSS OF INCOME, LOSS OF BUSINESS, LOSS OF PRODUCTION, LOSS OF OPPORTUNITY OR LOSS OF REPUTATION.

Some states do not allow limitations on how long an implied warranty lasts, so the above limitation may not apply to you. Some states do not allow the exclusion or limitation of incidental or consequential damages, so the above exclusions may not apply to you. This warranty gives you specific legal rights, and you may also have other rights which may vary from state to state.

To make a warranty claim, check first with the dealer from whom you purchased the product or visit www.xylem.com for the name and location of the nearest dealer providing warranty service.

Notice - Industrial Control Protocols

Certain Industrial Control Protocols do not offer security protections at protocol level and may be exposed to additional Cybersecurity risk. Customer security precautions including

physical security measures are an important layer of defense in such cases. The Xylem, e-HVX/e-HVXR systems are designed with the consideration that it would be deployed and operated in a physically secure location.

- Xylem suggests that physical access to cabinets and/or enclosures containing and the associated system should be restricted, monitored and logged at all times.
- Xylem recommends that customers inventory and document all industrial equipment running on their premises including model name, software version, and how devices are connected to each other and the local network.
- Xylem recommends creating and maintaining offline copies of configuration backups to all equipment involved in controlling critical processes.
- In cases where control commands for Xylem equipment are issued from SCADA or building management systems, Xylem recommends a regular check by operators to ensure the integrity of communications between these systems and Xylem equipment.
- Physical access to the communication lines should be restricted to prevent any attempts of wiretapping, sabotage. Best practice is to use metal conduits for the communication lines running between one cabinet to another cabinet.
- People with unauthorized physical access to the device could cause serious disruption of the device functionality. A combination of physical access controls to the location should be used, such as locks, card readers, and/or guards etc.
- hydrovar X supports the following physical access ports:
 - RJ45 connector for removable keypad as well as Modbus RTU communications
 - RJ45 for Modbus TCP communications
 - Terminal block for Modbus RTU and other Digital IOs
- Xylem suggests access to above physical ports need to be restricted.

Xylem Product Cybersecurity

Xylem values your system security and the availability of your critical services. For more information on Xylem cybersecurity practices or to contact the cybersecurity team please visit xylem.com/security.

Xylem |'zīləm|

- 1) The tissue in plants that brings water upward from the roots;
- 2) a leading global water technology company.

We're a global team unified in a common purpose: creating advanced technology solutions to the world's water challenges. Developing new technologies that will improve the way water is used, conserved, and re-used in the future is central to our work. Our products and services move, treat, analyze, monitor and return water to the environment, in public utility, industrial, residential and commercial building services settings. Xylem also provides a leading portfolio of smart metering, network technologies and advanced analytics solutions for water, electric and gas utilities. In more than 150 countries, we have strong, long-standing relationships with customers who know us for our powerful combination of leading product brands and applications expertise with a strong focus on developing comprehensive, sustainable solutions.

For more information on how Xylem can help you, go to www.xylem.com



Xylem Inc.
2881 East Bayard Street Ext., Suite A
Seneca Falls, NY 13148
USA
Tel: (844) XYL-PUMP [844-995-7867]
Fax: (888) 322-5877
www.xylem.com/bellgossett

Visit our Web site for the latest version of this document and more information

The original instruction is in English. All non-English instructions are translations of the original instruction.

© 2024 Xylem Inc.

Xylem and Bell & Gossett are registered trademarks of Xylem Inc. or one of its subsidiaries. All other trademarks or registered trademarks are property of their respective owners.