

# Series e-1531X & e-1532X

Integrated pump, motor & variable speed  
drive solutions, **powered by hydrovar® X**

**CONTENTS**

General Introduction ..... **3**

Applications and Benefits ..... **4**

Performance Coverage at 60 Hz, 2-poles and 4-poles..... **5**

Assembly Configurations ..... **6**

Specifications Document List ..... **12**

Electrical Data ..... **13**

Terminal Block ..... **18**

How to Read Smart Pump Series Curves ..... **19**

Performance Curves for High Speed Models ..... **20**

Performance Curves for Low Speed Models ..... **36**

Materials of Construction ..... **58**

Seal Assemblies ..... **58**

Dimensions and Weights ..... **59**

## GENERAL INTRODUCTION

Powered by Xylem's hydrovar® X Smart Motor, e-1531X & e-1532X Smart Pumps offer customizable pumping solutions designed to deliver ultra-premium efficiency, connectivity, and simplicity right out of the box!

e-1531X (footless volute) & e-1532X (footed volute) Smart Pumps leverage decades of expertise and know-how in pump technology to bring the right combination of motors, variable speed drives and hydraulic pumps in one comprehensive, highly efficient package. Series e-1531X & e-1532X spacesaving, close-coupled, end suction pumps have been designed to offer the highest overall efficiencies in the market for HVAC and plumbing applications.

With the largest "Efficiency Island" compared to other similar pumps, the e-1531X & e-1532X reduce electricity consumption, improves overall system performance and lowers life cycle costs. The extensive energy saving profile enables users to maintain significantly higher levels of efficiency over a much wider range of operating conditions.

So, when it's time to think efficiency, performance and reliable market-leading technology ... start with e-1531X & e-1532X Smart Pumps from Bell & Gossett - complete systems, delivering the solutions you need today.

## HYDRAULIC SPECIFICATIONS

- Maximum flow: up to **1600 GPM (363 m<sup>3</sup>/hr)**
- Maximum head: up to **400 ft TDH (123 m)**<sup>1</sup>
- Hydraulic performance compliant with **ANSI/HI 14.6 Grade 2B**
- Maximum temperature: up to 250 °F (121 °C)<sup>2</sup>
- Maximum working pressure: 175 psi (12 bar)<sup>1</sup>

<sup>1</sup> The 1.25BC and 1.5BC models may exceed the nominal 175 psi rating when operating above 3600 RPM in low-flow conditions. For reliable operation, observe the recommended maximum speed limits indicated on the individual performance curves.

<sup>2</sup> See mechanical seal options for temperature limitations.

## MOTOR SPECIFICATIONS

hydrovar X

- IES2 Power drive system (PDS) efficiency (IEC 61800-9-2:2017)
- IE5 Motor efficiency (IEC TS 60034-30-2:2016)
- NEMA 4
- Insulation class 115 (Class F)
- Totally enclosed fan cooled (TEFC) construction
- 3-Phase power supply
- Rated speeds (high speed models): 3000 - 4000 RPM<sup>3</sup>
- Rated speeds (low speed models): 1500 - 2000 RPM<sup>3</sup>
- High speed models: 3 kW to 22 kW (4 HP to 30 HP): 200-240V and 380-480V +/- 10%, 50/60Hz
- Low speed models: 1.5 kW to 11 kW (2 HP to 15 HP): 200-240V and 380-480V +/- 10%, 50/60Hz
- RS485 Communication interface, BACnet and Modbus standard and BLE included
- Overload and locked rotor protection with automatic reset included
- Multi-pump linking (up to 8 pumps)

<sup>3</sup> Rated speeds are used to determine the net efficiency of a pump-drive system and for energy efficiency listings. Pumps may or may not utilize the full speed range of hydrovar X depending on a variety of factors or limitations. Models may operate below rated speed at partial loading. See individual performance curves for more detail.

## APPLICATIONS

Series e-1531X & e-1532X Smart Pumps are suitable for the following applications:

- Chilled Water
- Commercial HVAC
- Hydronic Heating and Cooling Systems
- Cooling Towers and Industrial Uses
- Pressure Boosting
- General Liquid Transfer

## PUMPED FLUIDS

- Unheated domestic and fresh water
- Boiler feed water
- Condensate
- Benign liquids

## BENEFITS

e-1531X & e-1532X Smart Pumps provide the following benefits:

**Ease of installation and maintenance:** the integrated pump and hydrovar X motor package eliminates additional wiring, labor, and costs associated with a traditional variable frequency drive (VFD) package. The hydrovar X motor features a quick-connect electrical socket between the motor and drive for rapid maintenance.

**True back pullout design:** Ease in service is assured, while piping and motor remain undisturbed. Extended delays for repairs are virtually eliminated.

**Intelligent performance:** advanced control systems embedded within the hydrovar X motor are customizable for a wide range of applications and multi-pump support (up to 8 pumps) for parallel pumping installations.

**Simple:** the hydrovar X motor is easy to configure and commission. Follow the start-up genie to quickly tailor the motor to its intended application. Control selections and navigate menus via a full color graphical display.

**Built-in protections:** integrated functions protect the pump and motor when operating near the current and power limits of the system.

**High efficiency:** the IE5 "ultra-premium" hydrovar X motor provides one of the broadest efficiency ranges in the industry.

**Internally flushed mechanical seals:** ensure maximum seal face lubrication, heat dissipation and debris removal without vulnerable, external flush tubing. As much as 25 percent of the total pump flow continuously flushes the seal faces.

## PERFORMANCE COVERAGE

### e-1531X & e-1532X High Speed Hydraulic Performance

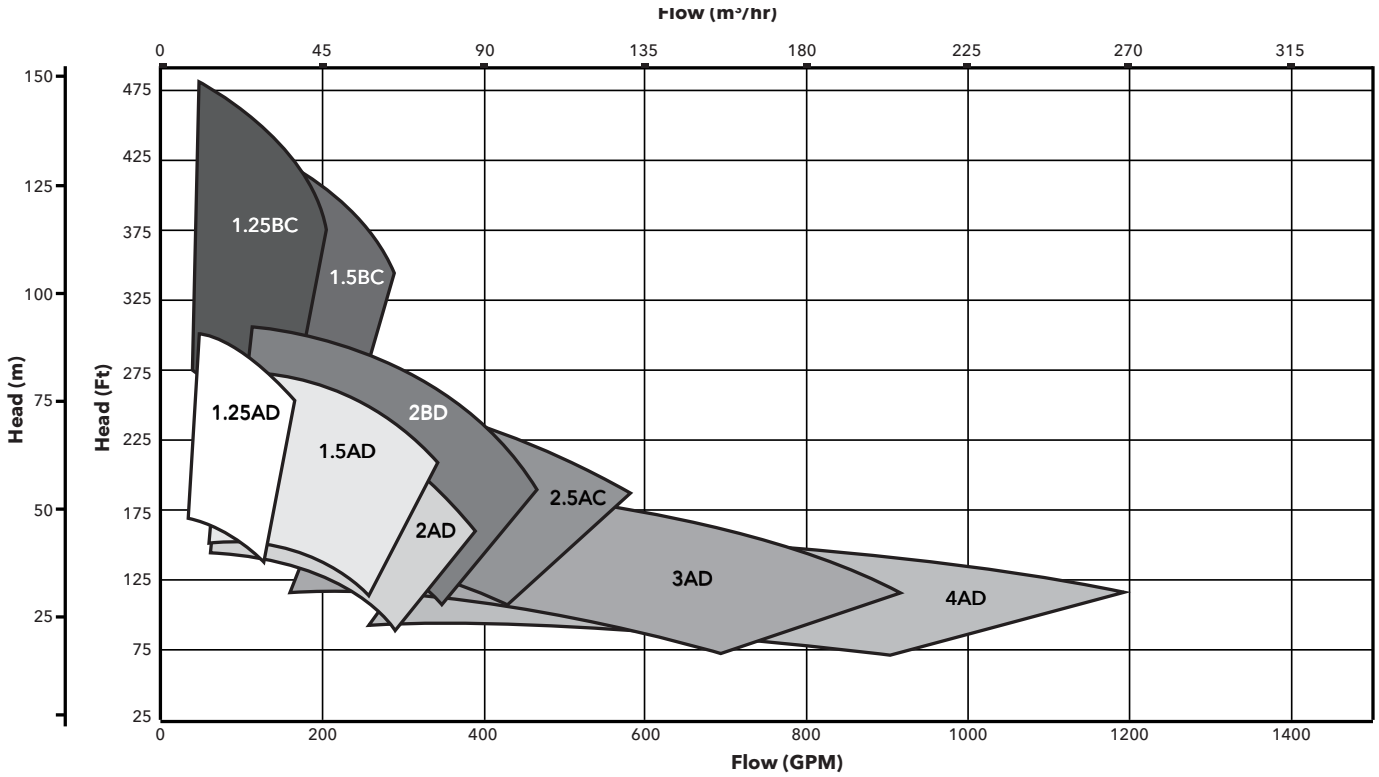

### e-1531X & e-1532X Low Speed Hydraulic Performance

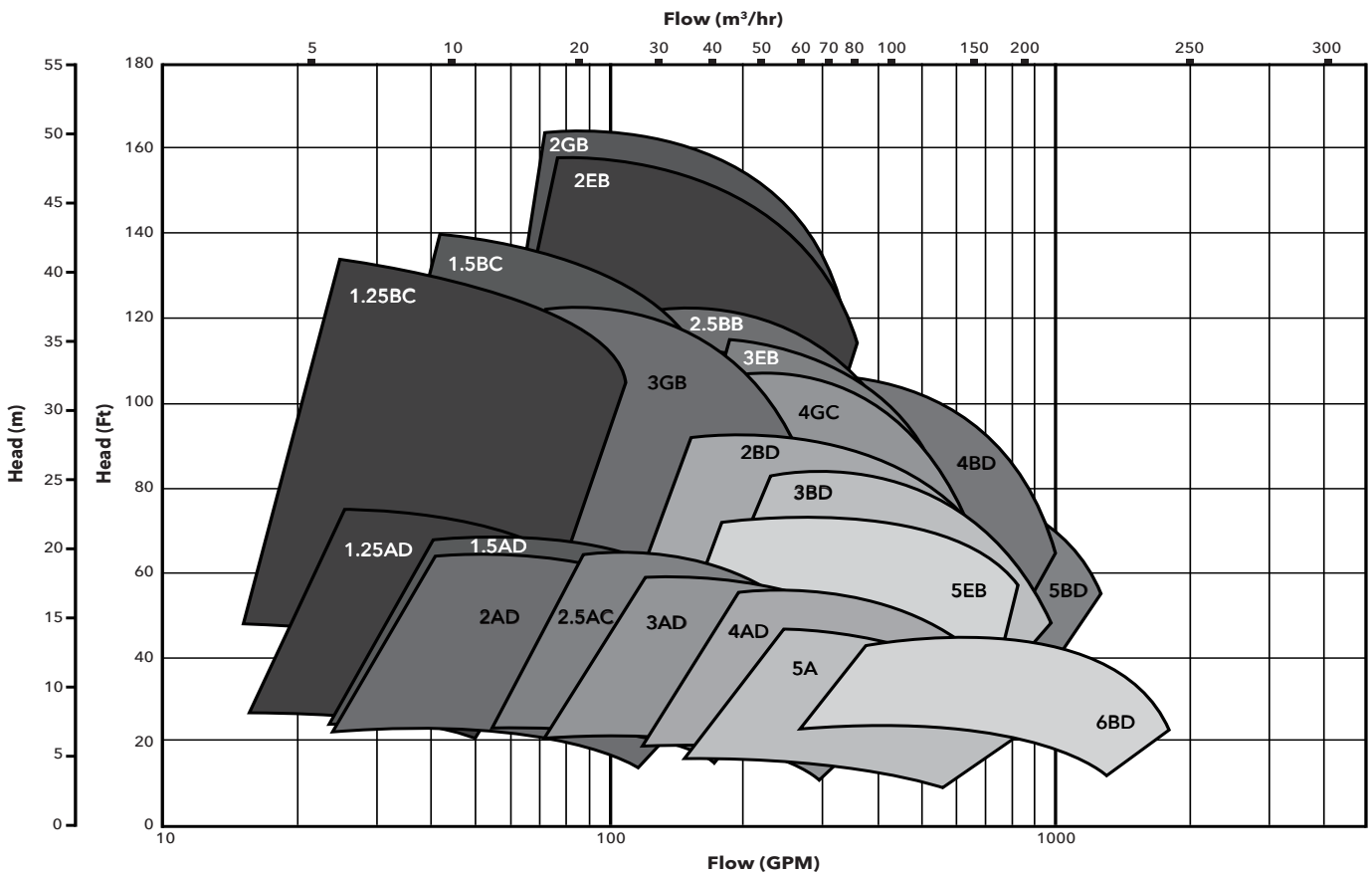

## e-1531X SERIES ASSEMBLY CONFIGURATIONS

### High Speed (3000-4000 RPM) 3 Phase - 380-480V (460V Nominal Voltage)

Pump Size	Motor Code	Motor Type	e-1531X BUNA PN	e-1531X EPR PN	Motor HP	e-1531 Frame	NEMA Frame	Impeller Trim (in.)
1.25AD	130636370	EXM213-215/4.150CH2	1531XA1M4SX1	1531XA1M4SX2	15	S	213JM	7
1.25AD	130635410	EXM143-145/4.075BH2	1531XA1L4SX1	1531XA1L4SX2	7.5	S	143JM	6
1.5AD	130636970	EXM254-256/4.200DH2	1531XB1N4SX1	1531XB1N4SX2	20	L	254JM	7
1.5AD	130636250	EXM213-215/4.100CH2	1531XB1R4SX1	1531XB1R4SX2	10	S	213JM	6
1.25BC	130637210	EXM254-256/4.300DH2	1531XA4Q4SX1	1531XA4Q4SX2	30	L	254JM	9
1.5BC	130637210	EXM254-256/4.300DH2	1531XB4Q4SX1	1531XB4Q4SX2	30	L	254JM	8.5
2.5AC	130637090	EXM254-256/4.250DH2	1531XD2P4SX1	1531XD2P4SX2	25	L	254JM	7
2.5AC	130636370	EXM213-215/4.150CH2	1531XD2M4SX1	1531XD2M4SX2	15	S	213JM	6
2AD	130636970	EXM254-256/4.200DH2	1531XC1P4SX1	1531XC1P4SX2	20	L	254JM	7
2AD	130636250	EXM213-215/4.100CH2	1531XC1R4SX1	1531XC1R4SX2	10	S	213JM	5.5
2BD	130637210	EXM254-256/4.300DH2	1531XC5Q4SX1	1531XC5Q4SX2	30	L	254JM	7.75
2BD	130636970	EXM254-256/4.200DH2	1531XC5N4SX1	1531XC5N4SX2	20	L	254JM	7
3AD	130637210	EXM254-256/4.300DH2	1531XE1Q4SX1	1531XE1Q4SX2	30	L	254JM	6.75
3AD	130637090	EXM254-256/4.250DH2	1531XE1P4SX1	1531XE1P4SX2	25	L	254JM	6.5
4AD	130637210	EXM254-256/4.300DH2	1531XF1Q4SX1	1531XF1Q4SX2	30	L	254JM	6

### High Speed (3000-4000 RPM) 3 Phase - 200-240V (230V Nominal Voltage)

Pump Size	Motor Code	Motor Type	e-1531X BUNA PN	e-1531X EPR PN	Motor HP	e-1531 Frame	NEMA Frame	Impeller Trim (in.)
1.25AD	130637691	EXM213-215/3.075CH2	1531XA1L4RX1	1531XA1L4RX2	7.5	S	213JM	6
1.5AD	130636971	EXM254-256/3.200DH2	1531XB1N4RX1	1531XB1N4RX2	20	L	254JM	7
1.25BC	130636971	EXM254-256/3.200DH2	1531XA4N4RX1	1531XA4N4RX2	20	L	254JM	8.25
1.5BC	130636971	EXM254-256/3.200DH2	1531XB4N4RX1	1531XB4N4RX2	20	L	254JM	7.5
2.5AC	130636971	EXM254-256/3.200DH2	1531XD2N4RX1	1531XD2N4RX2	20	L	254JM	6.5
2.5AC	130637771	EXM254-256/3.150DH2	1531XD2M4RX1	1531XD2M4RX2	15	L	254JM	6
2AD	130636971	EXM254-256/3.200DH2	1531XC1N4RX1	1531XC1N4RX2	20	L	254JM	7
2BD	130636971	EXM254-256/3.200DH2	1510XC5N4RX1	1510XC5N4RX2	20	L	254JM	7
3AD	130636971	EXM254-256/3.200DH2	1531XE1N4RX1	1531XE1N4RX2	20	L	254JM	5.875
4AD	130636971	EXM254-256/3.200DH2	1531XF1N4RX1	1531XF1N4RX2	20	L	254JM	5.125

## e-1531X SERIES ASSEMBLY CONFIGURATIONS

### Low Speed (1500-2000 RPM) 3 Phase - 380-480V (460V Nominal Voltage)

Pump Size	Motor Code	Motor Type	e-1531X BUNA PN	e-1531X EPR PN	Motor HP	e-1531 Frame	NEMA Frame	Impeller Trim (in.)
1.25AD	130635810	EXM143-145/4.030BH4	1531XA1J5SX1	1531XA1J5SX2	3	S	143JM	7
1.5AD	130635810	EXM143-145/4.030BH4	1531XB1J5SX1	1531XB1J5SX2	3	S	143JM	7
1.25BC	130636610	EXM213-215/4.055CH4	1531XA4K5SX1	1531XA4K5SX2	5.5	S	213JM	9.5
1.5BC	130636730	EXM213-215/4.075CH4	1531XB4L5SX1	1531XB4L5SX2	7.5	S	213JM	9.5
1.5BC	130636610	EXM213-215/4.055CH4	1531XB4K5SX1	1531XB4K5SX2	5.5	S	213JM	9
2.5AC	130636610	EXM213-215/4.055CH4	1531XD2K5SX1	1531XD2K5SX2	5.5	S	213JM	7
2AD	130635810	EXM143-145/4.030BH4	1531XC1J5SX1	1531XC1J5SX2	3	S	143JM	7
2BD	130636730	EXM213-215/4.075CH4	1531XC5L5SX1	1531XC5L5SX2	7.5	S	213JM	9.5
2BD	130636610	EXM213-215/4.055CH4	1531XC5K5SX1	1531XC5K5SX2	5.5	S	213JM	8.5
2.5BB	130637450	EXM254-256/4.100DH4	1531XD4R5SX1	1531XD4R5SX2	10	L	254JM	9.5
2.5BB	130636730	EXM213-215/4.075CH4	1531XD4L5SX1	1531XD4L5SX2	7.5	S	213JM	8.5
3AD	130636610	EXM213-215/4.055CH4	1531XE1K5SX1	1531XE1K5SX2	5.5	S	215JM	7
3BD	130637570	EXM254-256/4.150DH4	1531XE5M5SX1	1531XE5M5SX2	15	L	254JM	9.5
3BD	130637450	EXM254-256/4.100DH4	1531XE5R5SX1	1531XE5R5SX2	10	L	254JM	8.5
4AD	130636730	EXM213-215/4.075CH4	1531XF1L5SX1	1531XF1L5SX2	7.5	S	213JM	7
4BD	130637570	EXM254-256/4.150DH4	1531XF5M5SX1	1531XF5M5SX2	15	L	254JM	9.25
5A	130637450	EXM254-256/4.100DH4	1531XG3R5SX1	1531XG3R5SX2	10	L	254JM	7
5BD	130637570	EXM254-256/4.150DH4	1531XG5M5SX1	1531XG5M5SX2	15	L	254JM	8.25
6BD	130637570	EXM254-256/4.150DH4	1531XH5M5SX1	1531XH5M5SX2	15	L	254JM	7.5

## e-1531X SERIES ASSEMBLY CONFIGURATIONS

### Low Speed (1500-2000 RPM) 3 Phase - 200-240V (230V Nominal Voltage)

Pump Size	Motor Code	Motor Type	e-1531X BUNA PN	e-1531X EPR PN	Motor HP	e-1531 Frame	NEMA Frame	Impeller Trim (in.)
1.25AD	130635811	EXM143-145/3.030BH4	1531XA1J5RX1	1531XA1J5RX2	3	S	143JM	7
1.5AD	130635811	EXM143-145/3.030BH4	1531XB1J5RX1	1531XB1J5RX2	3	S	143JM	7
1.25BC	130636611	EXM213-215/3.055CH4	1531XA4K5RX1	1531XA4K5RX2	5.5	S	213JM	9.5
1.5BC	130636731	EXM213-215/3.075CH4	1531XB4L5RX1	1531XB4L5RX2	7.5	S	213JM	9.5
1.5BC	130636611	EXM213-215/3.055CH4	1531XB4K5RX1	1531XB4K5RX2	5.5	S	213JM	9
2.5AC	130636611	EXM213-215/3.055CH4	1531XD2K5RX1	1531XD2K5RX2	5.5	S	213JM	7
2AD	130635811	EXM143-145/3.030BH4	1531XC1J5RX1	1531XC1J5RX2	3	S	143JM	7
2BD	130636731	EXM213-215/3.075CH4	1531XC5L5RX1	1531XC5L5RX2	7.5	S	213JM	9.5
2BD	130636611	EXM213-215/3.055CH4	1531XC5K5RX1	1531XC5K5RX2	5.5	S	213JM	8.5
2.5BB	130637451	EXM254-256/3.100DH4	1531XD4R5RX1	1531XD4R5RX2	10	L	254JM	9.5
2.5BB	130636731	EXM213-215/3.075CH4	1531XD4L5RX1	1531XD4L5RX2	7.5	S	213JM	8.5
3AD	130636611	EXM213-215/3.055CH4	1531XE1K5RX1	1531XE1K5RX2	5.5	S	215JM	7
3BD	130637571	EXM254-256/3.150DH4	1531XE5M5RX1	1531XE5M5RX2	15	L	254JM	9.5
3BD	130637451	EXM254-256/3.100DH4	1531XE5R5RX1	1531XE5R5RX2	10	L	254JM	8.5
4AD	130636731	EXM213-215/3.075CH4	1531XF1L5RX1	1531XF1L5RX2	7.5	S	213JM	7
4BD	130637571	EXM254-256/3.150DH4	1531XF5M5RX1	1531XF5M5RX2	15	L	254JM	9.25
5A	130637451	EXM254-256/3.100DH4	1531XG3R5RX1	1531XG3R5RX2	10	L	254JM	7
5BD	130637571	EXM254-256/3.150DH4	1531XG5M5RX1	1531XG5M5RX2	15	L	254JM	8.25
6BD	130637571	EXM254-256/3.150DH4	1531XH5M5RX1	1531XH5M5RX2	15	L	254JM	7.5



### e-1532X SERIES ASSEMBLY CONFIGURATIONS

#### High Speed (3000-4000 RPM) 3 Phase - 380-480V (460V Nominal Voltage)

Pump Size	Motor Code	Motor Type	e-1532X BUNA PN	e-1532X EPR PN	Motor HP	e-1532 Frame	NEMA Frame	Impeller Trim (in.)
1.25AD	130636370	EXM213-215/4.150CH2	1532XA1M4SX1	1532XA1M4SX2	15	S	213JM	7
1.25AD	130635410	EXM143-145/4.075BH2	1532XA1L4SX1	1532XA1L4SX2	7.5	S	143JM	6
1.5AD	130636970	EXM254-256/4.200DH2	1532XB1N4SX1	1532XB1N4SX2	20	L	254JM	7
1.5AD	130636250	EXM213-215/4.100CH2	1532XB1R4SX1	1532XB1R4SX2	10	S	213JM	6
1.25BC	130637210	EXM254-256/4.300DH2	1532XA4Q4SX1	1532XA4Q4SX2	30	L	254JM	9
1.5BC	130637210	EXM254-256/4.300DH2	1532XB4Q4SX1	1532XB4Q4SX2	30	L	254JM	8.5
2.5AC	130637090	EXM254-256/4.250DH2	1532XD2P4SX1	1532XD2P4SX2	25	L	254JM	7
2.5AC	130636370	EXM213-215/4.150CH2	1532XD2M4SX1	1532XD2M4SX2	15	S	213JM	6
2AD	130636970	EXM254-256/4.200DH2	1532XC1N4SX1	1532XC1N4SX2	20	L	254JM	7
2AD	130636250	EXM213-215/4.100CH2	1532XC1R4SX1	1532XC1R4SX2	10	S	213JM	5.5
2BD	130637210	EXM254-256/4.300DH2	1532XC5Q4SX1	1532XC5Q4SX2	30	L	254JM	7.75
2BD	130636970	EXM254-256/4.200DH2	1532XC5N4SX1	1532XC5N4SX2	20	L	254JM	7
3AD	130637210	EXM254-256/4.300DH2	1532XE1Q4SX1	1532XE1Q4SX2	30	L	254JM	6.75
3AD	130637090	EXM254-256/4.250DH2	1532XE1P4SX1	1532XE1P4SX2	25	L	254JM	6.5
4AD	130637210	EXM254-256/4.300DH2	1532XF1Q4SX1	1532XF1Q4SX2	30	L	254JM	6

#### High Speed (3000-4000 RPM) 3 Phase - 200-240V (230V Nominal Voltage)

Pump Size	Motor Code	Motor Type	e-1532X BUNA PN	e-1532X EPR PN	Motor HP	e-1532 Frame	NEMA Frame	Impeller Trim (in.)
1.25AD	130637691	EXM213-215/3.075CH2	1532XA1L4RX1	1532XA1L4RX2	7.5	S	213JM	6
1.5AD	130636971	EXM254-256/3.200DH2	1532XB1N4RX1	1532XB1N4RX2	20	L	254JM	7
1.25BC	130636971	EXM254-256/3.200DH2	1532XA4N4RX1	1532XA4N4RX2	20	L	254JM	8.25
1.5BC	130636971	EXM254-256/3.200DH2	1532XB4N4RX1	1532XB4N4RX2	20	L	254JM	7.5
2.5AC	130636971	EXM254-256/3.200DH2	1532XD2N4RX1	1532XD2N4RX2	20	L	254JM	6.5
2.5AC	130637771	EXM254-256/3.150DH2	1532XD2M4RX1	1532XD2M4RX2	15	L	254JM	6
2AD	130636971	EXM254-256/3.200DH2	1532XC1N4RX1	1532XC1N4RX2	20	L	254JM	7
2BD	130636971	EXM254-256/3.200DH2	1532XC5N4RX1	1532XC5N4RX2	20	L	254JM	7
3AD	130636971	EXM254-256/3.200DH2	1532XE1N4RX1	1532XE1N4RX2	20	L	254JM	5.875
4AD	130636971	EXM254-256/3.200DH2	1532XF1N4RX1	1532XF1N4RX2	20	L	254JM	5.125

## e-1532X SERIES ASSEMBLY CONFIGURATIONS

### Low Speed (1500-2000 RPM) 3 Phase - 380-480V (460V Nominal Voltage)

Pump Size	Motor Code	Motor Type	e-1532X BUNA PN	e-1532X EPR PN	Motor HP	e-1532 Frame	NEMA Frame	Impeller Trim (in.)
1.25AD	130635810	EXM143-145/4.030BH4	1532XA1J5SX1	1532XA1J5SX2	3	S	143JM	7
1.5AD	130635810	EXM143-145/4.030BH4	1532XB1J5SX1	1532XB1J5SX2	3	S	143JM	7
1.25BC	130636610	EXM213-215/4.055CH4	1532XA4K5SX1	1532XA4K5SX2	5.5	S	213JM	9.5
1.5BC	130636730	EXM213-215/4.075CH4	1532XB4L5SX1	1532XB4L5SX2	7.5	S	213JM	9.5
1.5BC	130636610	EXM213-215/4.055CH4	1532XB4K5SX1	1532XB4K5SX2	5.5	S	213JM	9
2.5AC	130636610	EXM213-215/4.055CH4	1532XD2K5SX1	1532XD2K5SX2	5.5	S	213JM	7
2AD	130635810	EXM143-145/4.030BH4	1532XC1J5SX1	1532XC1J5SX2	3	S	143JM	7
2BD	130636730	EXM213-215/4.075CH4	1532XC5L5SX1	1532XC5L5SX2	7.5	S	213JM	9.5
2BD	130636610	EXM213-215/4.055CH4	1532XC5K5SX1	1532XC5K5SX2	5.5	S	213JM	8.5
2.5BB	130637450	EXM254-256/4.100DH4	1532XD11R5SX1	1532XD11R5SX2	10	L	254JM	9.5
2.5BB	130636730	EXM213-215/4.075CH4	1532XD11L5SX1	1532XD11L5SX2	7.5	S	213JM	8.5
3AD	130636610	EXM213-215/4.055CH4	1532XE1K5SX1	1532XE1K5SX2	5.5	L	215JM	7
3BD	130637570	EXM254-256/4.150DH4	1532XE5M5SX1	1532XE5M5SX2	15	L	254JM	9.5
3BD	130637450	EXM254-256/4.100DH4	1532XE5R5SX1	1532XE5R5SX2	10	S	254JM	8.5
4AD	130636730	EXM213-215/4.075CH4	1532XF1L5SX1	1532XF1L5SX2	7.5	S	213JM	7
4BD	130637570	EXM254-256/4.150DH4	1532XF5M5SX1	1532XF5M5SX2	15	L	254JM	9.25
5A	130637450	EXM254-256/4.100DH4	1532XG3R5SX1	1532XG3R5SX2	10	L	254JM	7
5BD	130637570	EXM254-256/4.150DH4	1532XG5M5SX1	1532XG5M5SX2	15	L	254JM	8.25
6BD	130637570	EXM254-256/4.150DH4	1532XH5M5SX1	1532XH5M5SX2	15	L	254JM	7.5
2EB	130637450	EXM254-256/4.100DH4	1532XC6R5SX1	1532XC6R5SX2	10	L	254JM	10.625
2EB	130636730	EXM213-215/4.075CH4	1532XC6L5SX1	1532XC6L5SX2	7.5	S	213JM	9.5
3EB	130637570	EXM254-256/4.150DH4	1532XE6M5SX1	1532XE6M5SX2	15	L	254JM	10.25
4EB	130637570	EXM254-256/4.150DH4	1532XF6M5SX1	1532XF6M5SX2	15	L	254JM	9.5
5EB	130637570	EXM254-256/4.150DH4	1532XG6M5SX1	1532XG6M5SX2	15	L	254JM	9
2GB	130637570	EXM254-256/4.150DH4	1532XC9M5SX1	1532XC9M5SX2	15	L	254JM	12
3GB	130637570	EXM254-256/4.150DH4	1532XE9M5SX1	1532XE9M5SX2	15	L	254JM	10.5
4GC	130637570	EXM254-256/4.150DH4	1532XF10M5SX1	1532XF10M5SX2	15	L	254JM	10

## e-1532X SERIES ASSEMBLY CONFIGURATIONS

### Low Speed (1500-2000 RPM) 3 Phase - 200-240V (230V Nominal Voltage)

Pump Size	Motor Code	Motor Type	e-1532X BUNA PN	e-1532X EPR PN	Motor HP	e-1532 Frame	NEMA Frame	Impeller Trim (in.)
1.25AD	130635811	EXM143-145/3.030BH4	1532XA1J5RX1	1532XA1J5RX2	3	S	143JM	7
1.5AD	130635811	EXM143-145/3.030BH4	1532XB1J5RX1	1532XB1J5RX2	3	S	143JM	7
1.25BC	130636611	EXM213-215/3.055CH4	1532XA4K5RX1	1532XA4K5RX2	5.5	L	213JM	9.5
1.5BC	130636731	EXM213-215/3.075CH4	1532XB4L5RX1	1532XB4L5RX2	7.5	S	213JM	9.5
1.5BC	130636611	EXM213-215/3.055CH4	1532XB4K5RX1	1532XB4K5RX2	5.5	S	213JM	9
2.5AC	130636611	EXM213-215/3.055CH4	1532XD2K5RX1	1532XD2K5RX2	5.5	S	213JM	7
2AD	130635811	EXM143-145/3.030BH4	1532XC1J5RX1	1532XC1J5RX2	3	S	143JM	7
2BD	130636731	EXM213-215/3.075CH4	1532XC5L5RX1	1532XC5L5RX2	7.5	L	213JM	9.5
2BD	130636611	EXM213-215/3.055CH4	1532XC5K5RX1	1532XC5K5RX2	5.5	L	213JM	8.5
2.5BB	130637451	EXM254-256/3.100DH4	1532XD11R5RX1	1532XD11R5RX2	10	L	254JM	9.5
2.5BB	130636731	EXM213-215/3.075CH4	1532XD11L5RX1	1532XD11L5RX2	7.5	S	213JM	8.5
3AD	130636611	EXM213-215/3.055CH4	1532XE1K5RX1	1532XE1K5RX2	5.5	S	215JM	7
3BD	130637571	EXM254-256/3.150DH4	1532XE5M5RX1	1532XE5M5RX2	15	S	254JM	9.5
3BD	130637451	EXM254-256/3.100DH4	1532XE5R5RX1	1532XE5R5RX2	10	S	254JM	8.5
4AD	130636731	EXM213-215/3.075CH4	1532XF1L5RX1	1532XF1L5RX2	7.5	S	213JM	7
4BD	130637571	EXM254-256/3.150DH4	1532XF5M5RX1	1532XF5M5RX2	15	L	254JM	9.25
5A	130637451	EXM254-256/3.100DH4	1532XG3R5RX1	1532XG3R5RX2	10	L	254JM	7
5BD	130637571	EXM254-256/3.150DH4	1532XG5M5RX1	1532XG5M5RX2	15	L	254JM	8.25
6BD	130637571	EXM254-256/3.150DH4	1532XH5M5RX1	1532XH5M5RX2	15	L	254JM	7.5
2EB	130637451	EXM254-256/3.100DH4	1532XC6R5RX1	1532XC6R5RX2	10	L	254JM	10.625
2EB	130636731	EXM213-215/3.075CH4	1532XC6L5RX1	1532XC6L5RX2	7.5	S	213JM	9.5
3EB	130637571	EXM254-256/3.150DH4	1532XE6M5RX1	1532XE6M5RX2	15	L	254JM	10.25
4EB	130637571	EXM254-256/3.150DH4	1532XF6M5RX1	1532XF6M5RX2	15	L	254JM	9.5
5EB	130637571	EXM254-256/3.150DH4	1532XG6M5RX1	1532XG6M5RX2	15	L	254JM	9
2GB	130637571	EXM254-256/3.150DH4	1532XC9M5RX1	1532XC9M5RX2	15	L	254JM	12
3GB	130637571	EXM254-256/3.150DH4	1532XE9M5RX1	1532XE9M5RX2	15	L	254JM	10.5
4GC	130637571	EXM254-256/3.150DH4	1532XF10M5RX1	1532XF10M5RX2	15	L	254JM	10

### hydrovar X MOTOR SPECIFICATIONS DOCUMENT LIST<sup>1</sup>

Speed Tier	Motor Type	Voltage Range	Power (hp)	Motor Frame	Specification Document Number
High Speed	EXM56/4.040BH2	380-480V	4	56	XY-hyXeXM-SUB-520
	EXM143-145/4.040BH2		4	143-145	XY-hyXeXM-SUB-521
	EXM143-145/4.055BH2		5.5	143-145	XY-hyXeXM-SUB-522
	EXM143-145/4.075BH2		7.5	143-145	XY-hyXeXM-SUB-523
	EXM213-215/4.075CH2		7.5	213-215	XY-hyXeXM-SUB-524
	EXM213-215/4.100CH2		10	213-215	XY-hyXeXM-SUB-525
	EXM213-215/4.150CH2		15	213-215	XY-hyXeXM-SUB-526
	EXM254-256/4.150DH2		15	254-256	XY-hyXeXM-SUB-527
	EXM254-256/4.200DH2		20	254-256	XY-hyXeXM-SUB-528
	EXM254-256/4.250DH2		25	254-256	XY-hyXeXM-SUB-529
	EXM254-256/4.300DH2		30	254-256	XY-hyXeXM-SUB-530
	EXM56/3.040BH2		200-240V	4	56
	EXM143-145/3.040BH2	4		143-145	XY-hyXeXM-SUB-536
	EXM213-215/3.075CH2	7.5		213-215	XY-hyXeXM-SUB-537
	EXM254-256/3.150DH2	15		254-256	XY-hyXeXM-SUB-538
	EXM254-256/3.200DH2	20		254-256	XY-hyXeXM-SUB-539
Low Speed	EXM56/4.020BH4	380-480V	2	56	XY-hyXeXM-SUB-542
	EXM56/4.030BH4		3	56	XY-hyXeXM-SUB-543
	EXM143-145/4.020BH4		2	143-145	XY-hyXeXM-SUB-544
	EXM143-145/4.030BH4		3	143-145	XY-hyXeXM-SUB-545
	EXM213-215/4.040CH4		4	213-215	XY-hyXeXM-SUB-546
	EXM213-215/4.055CH4		5.5	213-215	XY-hyXeXM-SUB-547
	EXM213-215/4.075CH4		7.5	213-215	XY-hyXeXM-SUB-548
	EXM254-256/4.075DH4		7.5	254-256	XY-hyXeXM-SUB-549
	EXM254-256/4.100DH4		10	254-256	XY-hyXeXM-SUB-550
	EXM254-256/4.150DH4		15	254-256	XY-hyXeXM-SUB-551
	EXM56/3.020BH4	200-240V	2	56	XY-hyXeXM-SUB-552
	EXM56/3.030BH4		3	56	XY-hyXeXM-SUB-553
	EXM143-145/3.020BH4		2	143-145	XY-hyXeXM-SUB-554
	EXM143-145/3.030BH4		3	143-145	XY-hyXeXM-SUB-555
	EXM213-215/3.040CH4		4	213-215	XY-hyXeXM-SUB-556
	EXM213-215/3.055CH4		5.5	213-215	XY-hyXeXM-SUB-557
	EXM213-215/3.075CH4		7.5	213-215	XY-hyXeXM-SUB-558
	EXM254-256/3.075DH4		7.5	254-256	XY-hyXeXM-SUB-559
	EXM254-256/3.100DH4		10	254-256	XY-hyXeXM-SUB-560
EXM254-256/3.150DH4	15	254-256	XY-hyXeXM-SUB-561		

<sup>1</sup> The table above consists of all NEMA frame hydrovar X motor types. Not all motor types are used in the e-1510X product line.

### hydrovar X ELECTRICAL DATA

\* Please note: Efficiency values shown are power-drive-system (PDS) efficiencies which include the combined losses from both the inverter and motor. The values shown correspond to the full load range of the hydrovar X motor. The hydrovar X motor may operate below the minimum rated speed at partial loading.

Table 1: 56 Frame, High Speed, 380-480V

Pn HP	MOTOR TYPE	NEMA FRAME	SPEED (RPM) min-1	INPUT CURRENT (I) 380-480V A	DATA RELATED TO 460V						
					In	POWER FACTOR cos (φ)	Tn lb.ft	*PDS EFFICIENCY η%			
					A			100	75	50	
4.0	EXM56/4.040BH2	56	3000	6.7-5.3	5.4	0.80	7.04	87.6	87.5	86.0	
			3600		5.3			5.87	88.0	87.4	85.4
			4000		5.3			5.28	88.1	87.1	84.9

Table 2: 56 Frame, High Speed, 200-240V

Pn HP	MOTOR TYPE	NEMA FRAME	SPEED (RPM) min-1	INPUT CURRENT (I) 200-240V A	DATA RELATED TO 230V						
					In	POWER FACTOR cos (φ)	Tn lb.ft	*PDS EFFICIENCY η%			
					A			100	75	50	
4.0	EXM56/3.040BH2	56	-	10.7-8.9	-	0.94	-	-	-	-	
			3600		9.2			5.87	87.2	87.1	85.9
			4000		9.1			5.28	88.0	87.8	86.4

Table 3: 143-145 Frame High Speed, 380-480V

Pn HP	MOTOR TYPE	NEMA FRAME	SPEED (RPM) min-1	INPUT CURRENT (I) 380-480V A	DATA RELATED TO 460V						
					In	POWER FACTOR cos (φ)	Tn lb.ft	*PDS EFFICIENCY η%			
					A			100	75	50	
4.0	EXM143- 145/4.040BH2	143-145	3000	6.7-5.3	5.4	0.80	7.04	87.6	87.5	86.0	
			3600		5.3			5.87	88.0	87.4	85.4
			4000		5.3			5.28	88.1	87.1	84.9
5.5	EXM143- 145/4.055BH2		3000	7.7-6.6	6.8	0.86	9.39	87.3	87.7	87.5	
			3600		6.6			7.83	89.1	88.8	87.3
			4000		6.5			7.04	89.1	88.5	86.8
7.5	EXM143- 145/4.075BH2		3000	10.2-8.4	8.6	0.89	12.91	89.9	89.9	89.2	
			3600		8.6			10.76	89.7	89.5	88.5
			4000		8.4			9.68	90.5	89.4	87.4

### hydrovar X ELECTRICAL DATA

Table 4: 143-145 Frame High Speed, 200-240V

Pn HP	MOTOR TYPE	NEMA FRAME	SPEED (RPM) min-1	INPUT CURRENT (I) 200-240V A	DATA RELATED TO 230V					
					In A	POWER FACTOR cos (φ)	Tn lb.ft	*PDS EFFICIENCY η%		
								100	75	50
4.0	EXM143- 145/3.040BH2	143-145	3000	10.7-8.9	-	0.94	-	-	-	-
			3600		9.2		5.87	87.2	87.1	85.9
			4000		9.1		5.28	88.0	87.8	86.4
5.5	EXM143- 145/3.055BH2		3000	Unavailable						
			3600	Unavailable						
			4000	Unavailable						
7.5	EXM143- 145/3.075BH2		3000	Unavailable						
			3600	Unavailable						
			4000	Unavailable						

Table 5: 213-215 Frame, High Speed, 380-480V

Pn HP	MOTOR TYPE	NEMA FRAME	SPEED (RPM) min-1	INPUT CURRENT (I) 380-480V A	DATA RELATED TO 460V					
					In A	POWER FACTOR cos (φ)	Tn lb.ft	*PDS EFFICIENCY η%		
								100	75	50
7.50	EXM213- 215/4.075CH2	213-215	3000	11.4-11.0	11.1	0.72	12.92	90.5	90.1	88.8
			3600		10.6		10.76	90.8	90.1	88.5
			4000		10.6		9.68	90.5	89.5	87.4
10.0	EXM213- 215/4.100CH2		3000	14.4-12.5	12.2	0.85	17.61	90.8	90.1	88.4
			3600		12.4		14.67	90.2	89.2	87.0
			4000		12.0		13.20	90.6	89.5	87.1
15.0	EXM213- 215/4.150CH2		3000	20.3-16.5	16.8	0.90	25.82	91.2	90.7	89.3
			3600		16.9		21.52	91.1	90.5	89.1
			4000		17.0		19.37	90.6	90.2	88.4

Table 6: 213-215 Frame, High Speed, 200-240V

Pn HP	MOTOR TYPE	NEMA FRAME	SPEED (RPM) min-1	INPUT CURRENT (I) 200-240V A	DATA RELATED TO 230V					
					In A	POWER FACTOR cos (φ)	Tn lb.ft	*PDS EFFICIENCY η%		
								100	75	50
7.50	EXM213- 215/3.075CH2	213-215	3000	18.9-16.2	16.7	0.94	12.92	89.6	89.3	88.2
			3600		16.3		10.76	89.9	89.2	87.6
			4000		16.6		9.68	88.6	87.6	85.1
10.0	EXM213- 215/3.100CH2		3000	Unavailable						
			3600	Unavailable						
			4000	Unavailable						
15.0	EXM213- 215/3.150CH2		3000	Unavailable						
			3600	Unavailable						
			4000	Unavailable						

### hydrovar X ELECTRICAL DATA

Table 7: 254-256 Frame, High Speed, 380-480V

Pn HP	MOTOR TYPE	NEMA FRAME	SPEED (RPM) min-1	INPUT CURRENT (I) 380-480V A	DATA RELATED TO 460V					
					In A	POWER FACTOR cos (φ)	Tn lb.ft	*PDS EFFICIENCY η%		
								100	75	50
15.00	EXM254- 256/4.150DH2	254-256	3000	24.5-22.8	21.7	0.72	25.82	91.7	91.2	90.2
			3600		20.9		21.52	92.0	91.2	89.9
			4000		20.5		19.37	91.5	90.6	88.8
20.0	EXM254- 256/4.200DH2		3000	30.2-27.1	24.5	0.76	35.22	91.5	91.2	90.1
			3600		27.0		29.35	92.1	91.4	90.1
			4000		26.8		26.41	91.8	91.1	89.6
25.0	EXM254- 256/4.250DH2		3000	33.5-28.6	29.4	0.87	43.44	91.7	91.4	90.7
			3600		28.9		36.19	92.1	91.5	90.4
			4000		28.8		32.58	92.0	91.4	90.2
30.0	EXM254- 256/4.300DH2		3000	38.9-32.4	33.5	0.90	51.65	92.1	91.7	90.7
			3600		33.3		43.04	92.5	91.8	90.6
			4000		32.7		38.83	92.4	91.6	90.2

Table 8: 254-256 Frame, High Speed, 200-240V

Pn HP	MOTOR TYPE	NEMA FRAME	SPEED (RPM) min-1	INPUT CURRENT (I) 200-240V A	DATA RELATED TO 230V						
					In A	POWER FACTOR cos (φ)	Tn lb.ft	*PDS EFFICIENCY η%			
								100	75	50	
15.00	EXM254- 256/3.150DH2	254-256	3000	38.4-34.1	35.4	0.90	25.82	90.3	90.3	89.4	
			3600		33.7		21.52	91.2	90.8	89.7	
			4000		32.5		19.37	91.3	90.6	89.3	
20.0	EXM254- 256/3.200DH2		-	50.0-44.1	-	0.92	-	-	-	-	
			3600		44.9		29.35	91.1	90.6	89.5	
			4000		44.4		26.41	90.3	89.4	87.5	
25.0	EXM254- 256/3.250DH2		3000	-	-	-	-	-	-	-	
			3600								Unavailable
			4000								
30.0	EXM254- 256/3.300DH2		3000	-	-	-	-	-	-	-	
			3600								Unavailable
			4000								

Table 9: 56 Frame, Low Speed, 380-480V

Pn HP	MOTOR TYPE	NEMA FRAME	SPEED (RPM) min-1	INPUT CURRENT (I) 380-480V A	DATA RELATED TO 460V					
					In A	POWER FACTOR cos (φ)	Tn lb.ft	*PDS EFFICIENCY η%		
								100	75	50
2.0	EXM56/4.020BH4	56	1500	4.0-3.8	3.70	0.57	7.04	82.2	83.2	83.0
			1800		3.90		5.87	85.1	85.9	85.6
			2000		3.50		5.28	86.7	86.4	85.3
3.0	EXM56/4.030BH4		1500	5.0-4.6	4.70	0.69	10.33	85.6	85.8	84.9
			1800		4.60		8.61	88.0	87.6	86.5
			2000		4.50		7.74	89.0	88.6	87.3

### hydrovar X ELECTRICAL DATA

Table 10: HX-B-LS-LV

Pn HP	MOTOR TYPE	NEMA FRAME	SPEED (RPM) min-1	INPUT CURRENT (I) 200-240V A	DATA RELATED TO 230V						
					In A	POWER FACTOR cos (φ)	Tn lb.ft	*PDS EFFICIENCY η%			
								100	75	50	
2.0	EXM56/3.020BH4	56	1500	5.7-4.9	5.1	0.89	7.04	83.2	83.8	83.5	
			1800		4.9			5.87	85.7	85.9	85.3
			2000		4.9			5.28	86.5	85.7	83.6
3.0	EXM56/3.030BH4		1500	7.9-6.7	7.00	0.93	10.33	86.0	86.3	86.2	
			1800		6.80			8.63	87.9	87.7	86.8
			2000		6.70			7.74	88.9	88.9	87.9

Table 11: HX-B-LS-HV

Pn HP	MOTOR TYPE	NEMA FRAME	SPEED (RPM) min-1	INPUT CURRENT (I) 380-480V A	DATA RELATED TO 460V						
					In A	POWER FACTOR cos (φ)	Tn lb.ft	*PDS EFFICIENCY η%			
								100	75	50	
2.0	EXM143- 145/4.020BH4	143-145	1500	4.0-3.8	3.70	0.57	7.04	82.2	83.2	83.0	
			1800		3.90			5.87	85.1	85.9	85.6
			2000		3.50			5.28	86.7	86.4	85.3
3.0	EXM143- 145/4.030BH4		1500	5.0-4.6	4.70	0.69	10.33	85.6	85.8	84.9	
			1800		4.60			8.61	88.0	87.6	86.5
			2000		4.50			7.74	89.0	88.6	87.3

Table 12: 143-145 Frame, Low Speed, 200-240V

Pn HP	MOTOR TYPE	NEMA FRAME	SPEED (RPM) min-1	INPUT CURRENT (I) 200-240V A	DATA RELATED TO 230V						
					In A	POWER FACTOR cos (φ)	Tn lb.ft	*PDS EFFICIENCY η%			
								100	75	50	
2.0	EXM143- 145/3.020BH4	143-145	1500	5.7-4.9	5.1	0.89	7.04	83.2	83.8	83.5	
			1800		4.9			5.87	85.7	85.9	85.3
			2000		4.9			5.28	86.5	85.7	83.6
3.0	EXM143- 145/3.030BH4		1500	7.9-6.7	7.00	0.93	10.33	86.0	86.3	86.2	
			1800		6.80			8.63	87.9	87.7	86.8
			2000		6.70			7.74	88.9	88.9	87.9

Table 13: HX-C-LS-HV

Pn HP	MOTOR TYPE	NEMA FRAME	SPEED (RPM) min-1	INPUT CURRENT (I) 380-480V A	DATA RELATED TO 460V						
					In A	POWER FACTOR cos (φ)	Tn lb.ft	*PDS EFFICIENCY η%			
								100	75	50	
4.0	EXM213- 215/4.040CH4	213-215	1500	7.9-7	7.2	0.62	14.09	86.3	86.6	85.7	
			1800		6.9			11.73	88.1	87.9	86.8
			2000		7			10.55	88.5	88.2	87.1
5.5	EXM213- 215/4.055CH4		1500	9.2-8.5	8.9	0.66	18.78	89.4	89.4	88.8	
			1800		8.4			15.65	91.2	91.1	90.4
			2000		8.3			14.09	91.6	91.5	90.8
7.5	EXM213- 215/4.075CH4		1500	11.2-10.2	10.3	0.75	25.82	90.7	90.8	90.4	
			1800		10.1			21.52	91.6	91.8	90.6
			2000		10.1			19.37	91.6	91.3	90.5



### hydrovar X ELECTRICAL DATA

Table 14: HX-C-LS-LV

Pn HP	MOTOR TYPE	NEMA FRAME	SPEED (RPM) min-1	INPUT CURRENT (I) 200-240V A	DATA RELATED TO 230V						
					In	POWER FACTOR cos (φ)	Tn lb.ft	*PDS EFFICIENCY η%			
					A			100	75	50	
4.00	EXM213- 215/3.040CH4	213-215	1500	11.0-9.8	9.9	0.87	14.09	87.2	87.4	87.1	
			1800		9.8			11.73	88.3	88.3	87.7
			2000		9.8			10.55	88.4	88.7	87.7
5.5	EXM213- 215/3.055CH4		1500	14.0-12.3	12.5	0.92	18.81	88.4	88.8	88.7	
			1800		12.2			15.64	89.9	89.8	89.3
			2000		12.1			14.09	90.2	90.4	89.6
7.5	EXM213- 215/3.075CH4		1500	21.6-20.4	16.6	0.93	25.82	89.4	89.7	89.5	
			1800		16.5			21.52	90.2	90.5	90.2
			2000		16.6			19.37	90.1	90.4	90.1

Table 15: 254-256 Frame, Low Speed, 380-480V

Pn HP	MOTOR TYPE	NEMA FRAME	SPEED (RPM) min-1	INPUT CURRENT (I) 380-480V A	DATA RELATED TO 460V						
					In	POWER FACTOR cos (φ)	Tn lb.ft	*PDS EFFICIENCY η%			
					A			100	75	50	
7.50	EXM254- 256/4.075DH4	254-256	1500	15.3-13.6	14.1	0.55	25.82	88.6	88.6	87.9	
			1800		13.8			21.52	90.9	90.7	89.8
			2000		14.3			19.37	91.0	91.1	90.4
10.0	EXM254- 256/4.100DH4		1500	18.7-17.4	17.8	0.60	35.22	89.6	89.9	89.7	
			1800		17.3			29.35	91.0	90.8	89.9
			2000		17.2			26.41	91.3	91.2	90.1
15.0	EXM254- 256/4.150DH4		1500	24.5-22.8	22.9	0.66	51.65	91.1	91.2	90.7	
			1800		22.7			43.04	92.0	91.7	90.8
			2000		22.2			38.74	92.6	92.3	91.4

Table 16: 254-256 Frame, Low Speed, 200-240V

Pn HP	MOTOR TYPE	NEMA FRAME	SPEED (RPM) min-1	INPUT CURRENT (I) 200-240V A	DATA RELATED TO 230V						
					In	POWER FACTOR cos (φ)	Tn lb.ft	*PDS EFFICIENCY η%			
					A			100	75	50	
7.50	EXM254- 256/3.075DH4	254-256	1500	20.5-18.8	19.2	0.83	25.81	88.0	88.4	88.2	
			1800		18.6			21.54	88.9	88.6	87.6
			2000		18			19.40	89.8	89.6	88.8
10.0	EXM254- 256/3.100DH4		1500	27.5-24.8	25.4	0.88	35.22	88.9	89.3	89.1	
			1800		23.5			29.35	90.7	90.7	90.3
			2000		23.3			26.41	91.2	91.2	90.6
15.0	EXM254- 256/3.150DH4		1500	39.0-34.5	35.6	0.9	51.65	89.6	90.1	90.0	
			1800		33.6			43.05	91.1	91.0	90.6
			2000		32.9			38.74	91.5	91.2	90.5

### TERMINAL BLOCK hydrovar X

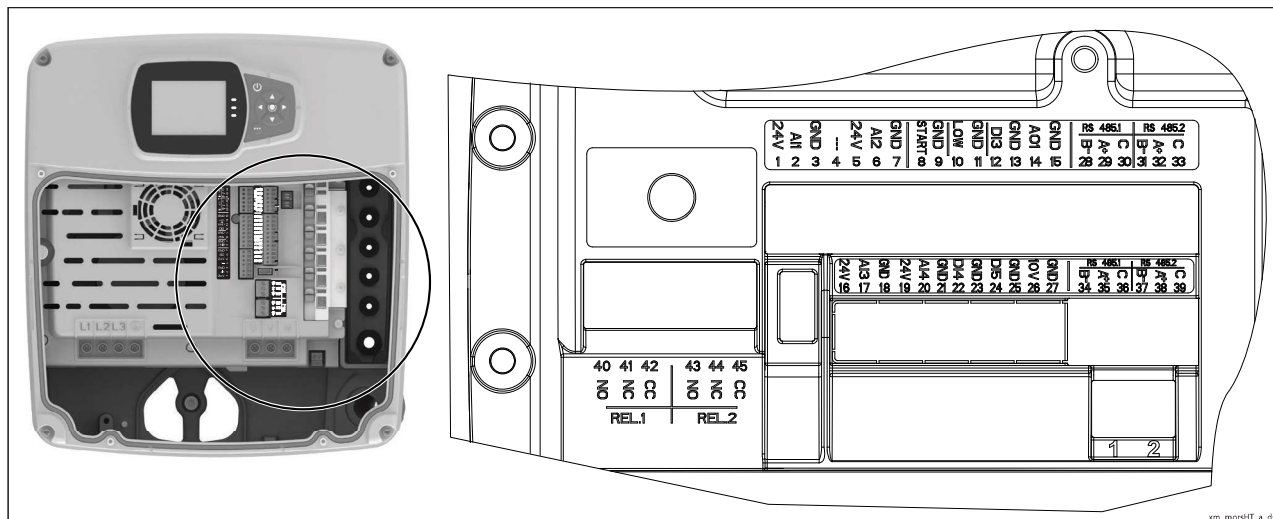

REF.	ITEM	DESCRIPTION	DEFAULT
1		Power supply +24 VDC, max. 60mA (total, terminals 1 + 5)	
2	Analog Input 1	Configurable Analog Input 1	Pressure Sensor 1
3		Electronic GND	
4	Not used	Internal use - Do not connect	
5		Power supply +24 VDC, max. 60mA (total, terminals 1 + 5)	
6	Analog Input 2	Configurable Analog Input 2	Not used
7		Electronic GND	
8	External Start/Stop	Start/Stop digital input, +24 VDC internal pull-up, 6mA contact current	-
9		Electronic GND	
10	External Lack of Water	Low water digital input, +24 VDC internal pull-up, 6mA contact current	-
11		Electronic GND	
12	Digital Input 3	Configurable Digital Input 3, +24 VDC internal pull-up, 6mA contact current	Solo Run
13		Electronic GND	
14	Analog Output	Configurable Analog Output	Motor Speed
15		Electronic GND	
16		Power supply +24 VDC, max. 60mA (total, terminals 16 and 19)	
17	Analog Input 3	Configurable Analog Input 3	Not used
18		Electronic GND	
19		Power supply +24 VDC, max. 60mA (total, terminals 16 and 19)	
20	Analog Input 4	Configurable Analog Input 4	Not used
21		Electronic GND	
22	Digital Input 4	Configurable Digital Input 4, +24 VDC internal pull-up, 6mA contact current	Not used
23		Electronic GND	
24	Digital Input 5	Configurable Digital Input 5, +24 VDC internal pull-up, 6mA contact current	Not used
25		Electronic GND	
26	10 VDC supply	Power supply +10 VDC, max. 3mA	-
27		Electronic GND	
28	Communication bus 1	RS485 port 1: RS485-1B N (-)	Multipump
29		RS485 port 1: RS485-1A P (+)	
30		RS485 port 1: RS485-COM	
31	Communication bus 2	RS485 port 2: RS485-2B N (-)	Modbus
32		RS485 port 2: RS485-2A P (+)	
33		RS485 port 2: RS485-COM	
34	Communication bus 1	RS485 port 1: RS485-1B N (-)	Multipump
35		RS485 port 1: RS485-1A P (+)	
36		RS485 port 1: RS485-COM	
37	Communication bus 2	RS485 port 2: RS485-2B N (-)	Modbus
38		RS485 port 2: RS485-2A P (+)	
39		RS485 port 2: RS485-COM	
40	Relay 1	Configurable relay 1: Normally Open	Running
41		Configurable relay 1: Normally Closed	
42		Configurable relay 1: Common Contact	
43	Relay 2	Configurable relay 2: Normally Open	Error
44		Configurable relay 2: Normally Closed	
45		Configurable relay 2: Common Contact	

### HOW TO READ SMART PUMP SERIES CURVES

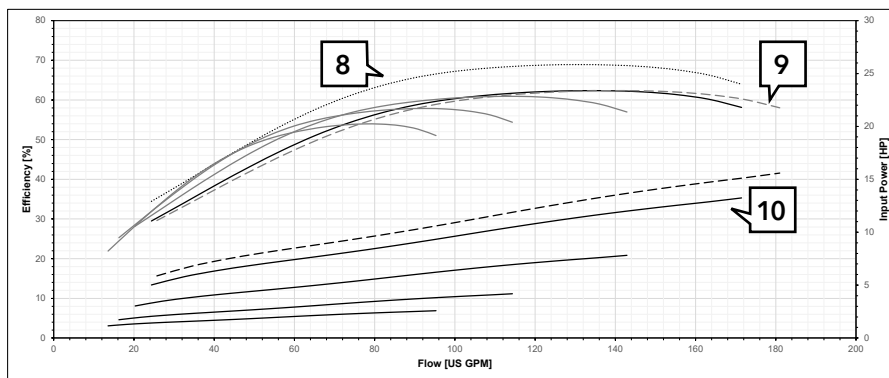
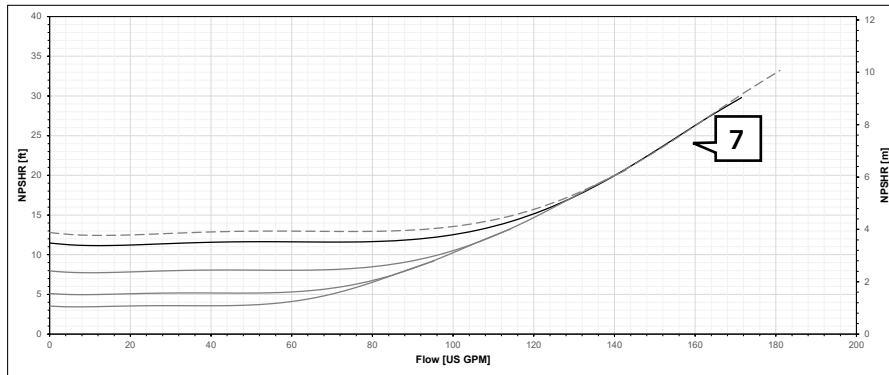
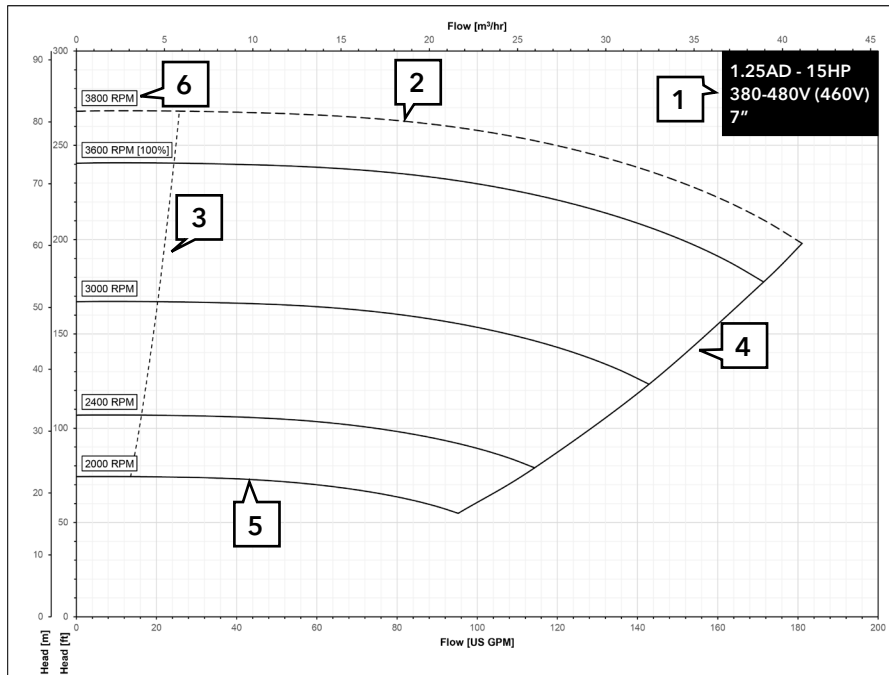

- 1. Model Information:** pump model and motor information.
- 2. Maximum Speed Curve:** the maximum operating speed of the pump. Any speed above the nominal speed rating (i.e. 1800 RPM or 3600 RPM) is indicated by a dashed line.
- 3. Minimum Continuous Stable Flow:** the recommended minimum flow rate of the pump.
- 4. Maximum Flow Curve:** the recommended maximum flow rate of the pump.
- 5. Minimum Speed Curve:** the minimum operating speed of the pump for continuous operation.
- 6. Speed Tags:** indicate the motor speed of a given performance curve. The [100%] modifier indicates the default maximum speed setting of the motor.
- 7. NPSH Curve:** the net positive suction head required of the pump. The dashed NPSH curve corresponds to the maximum speed condition. The solid black NPSH curve represents the NPSH operating at the [100%] speed. Subsequent NPSH curves represent NPSH required by speed in decreasing order.
- 8. Pump Efficiency Curve:** the standalone efficiency of the pump operating at the [100%] speed condition.
- 9. Efficiency Overall:** the overall efficiency (wire-to-water efficiency) of the pump and motor per speed.
- 10. Input Power:** the input power required to drive the motor by speed.

Series e-1531X & e-1532X PERFORMANCE CURVES FOR HIGH SPEED MODELS

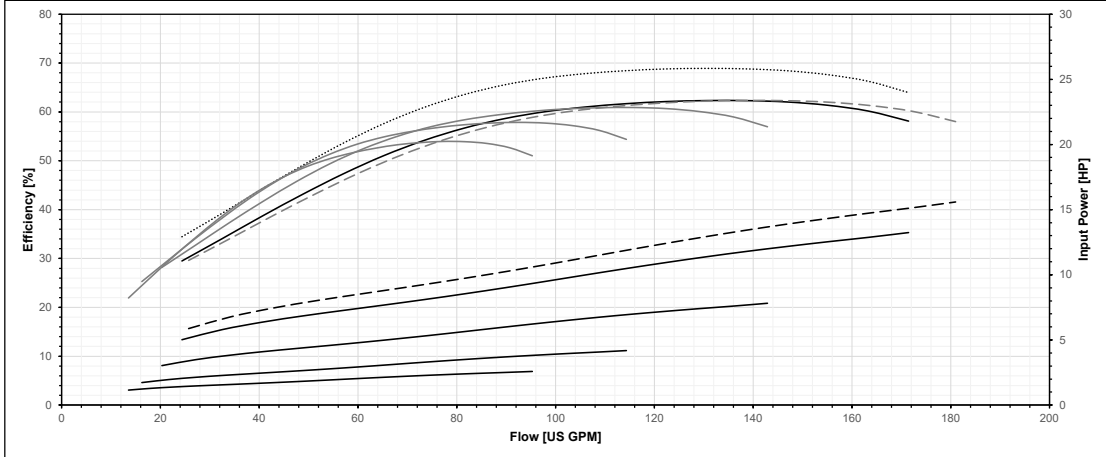
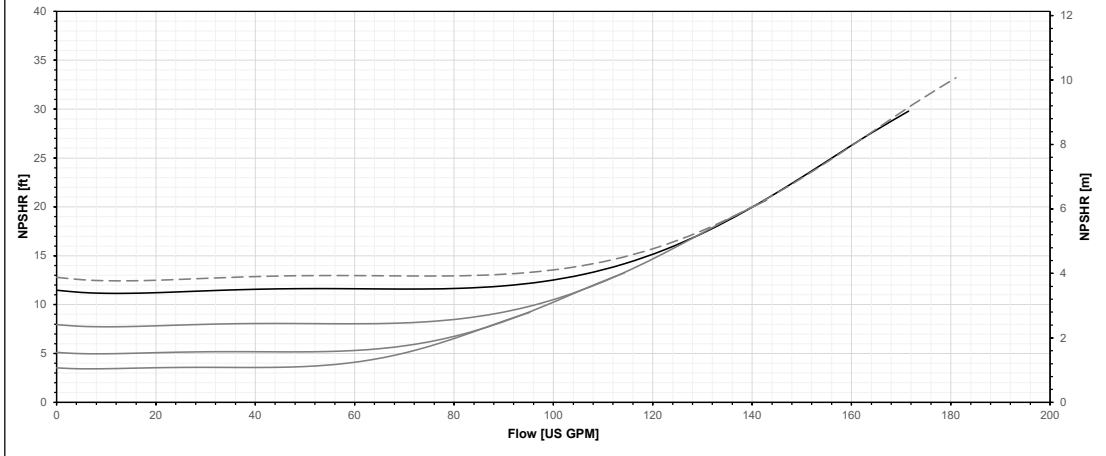
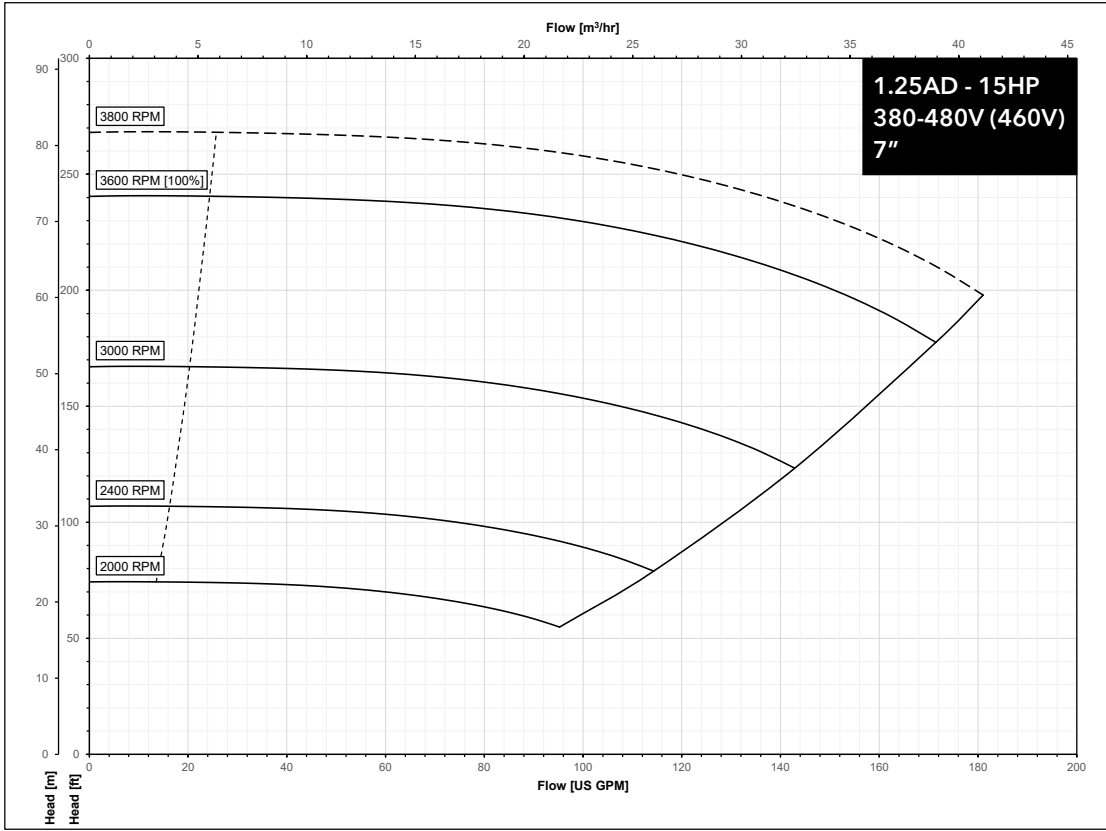

## Series e-1531X & e-1532X PERFORMANCE CURVES FOR HIGH SPEED MODELS

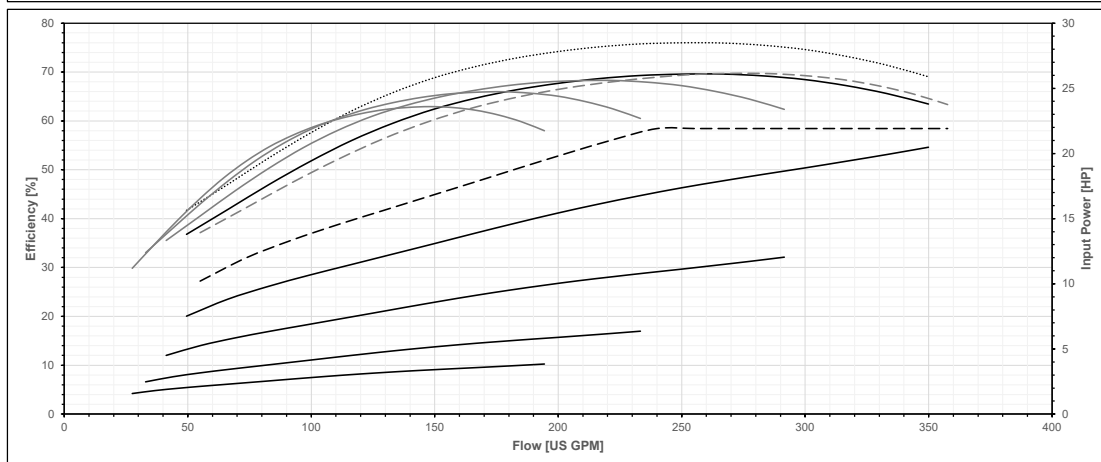
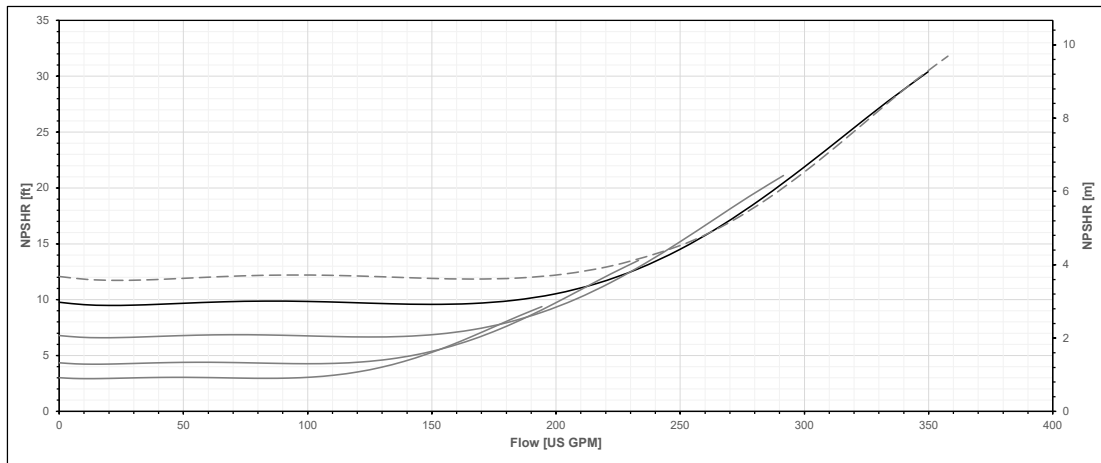
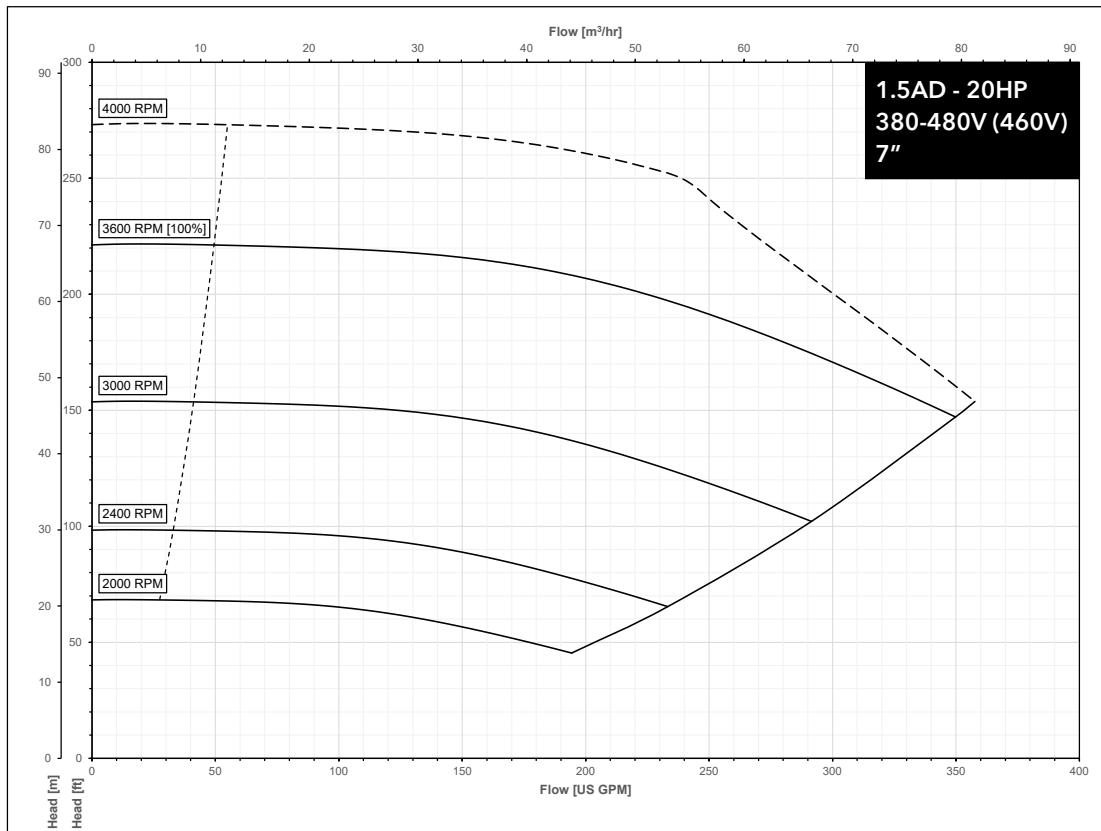

Series e-1531X & e-1532X PERFORMANCE CURVES FOR HIGH SPEED MODELS

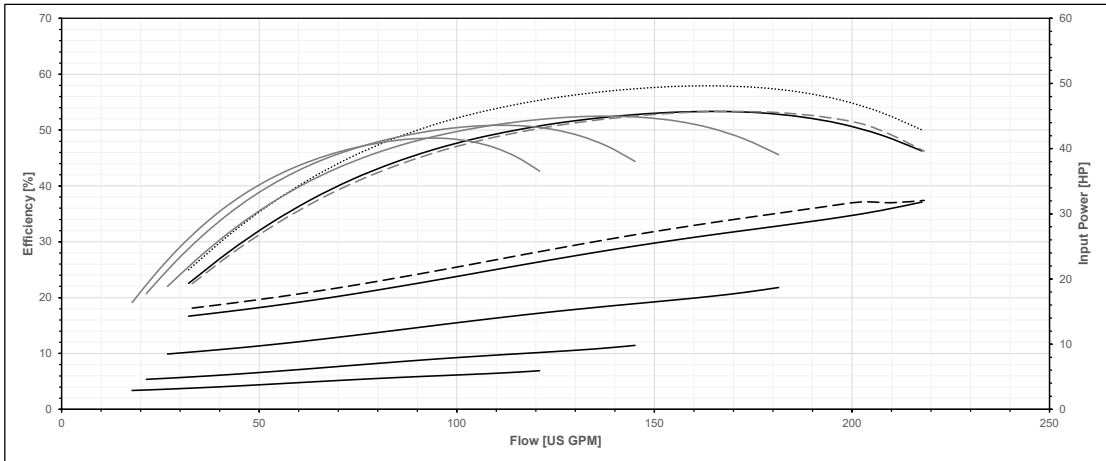
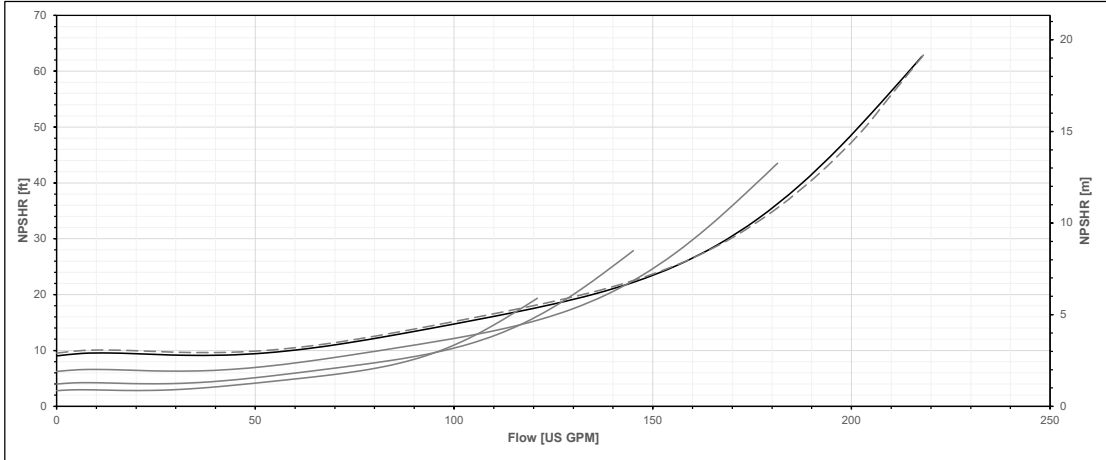
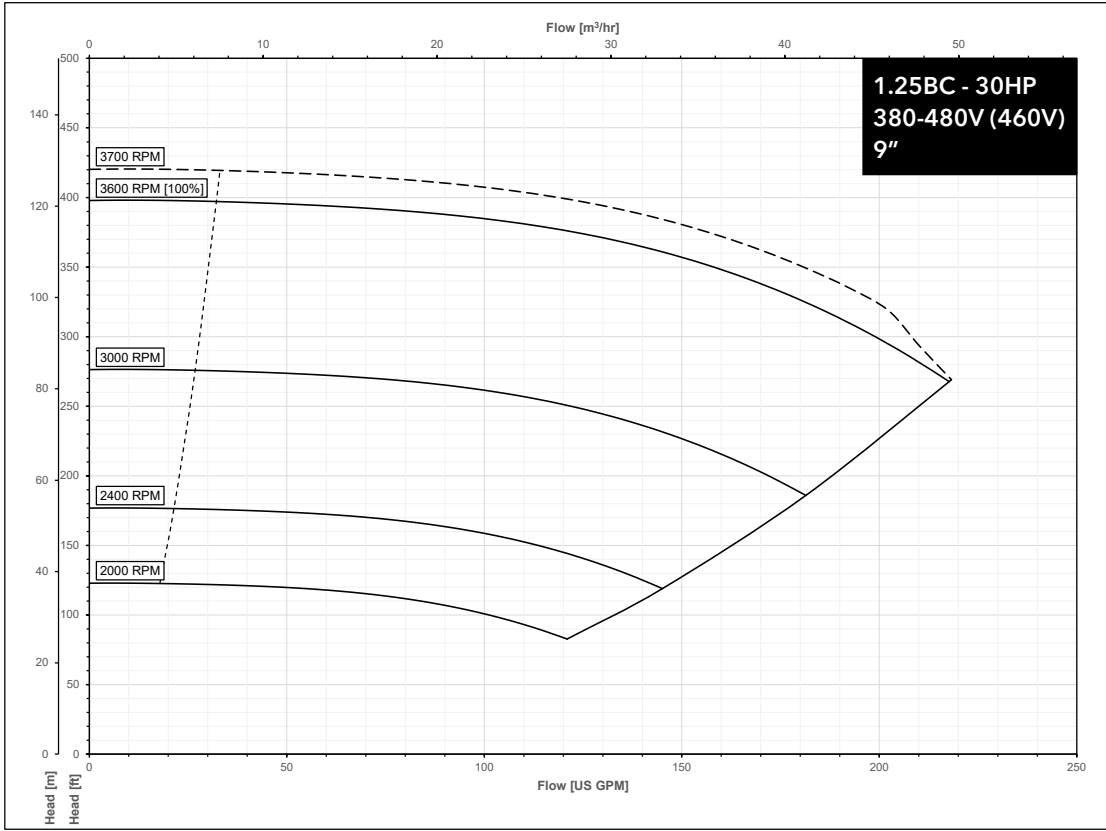

### Series e-1531X & e-1532X PERFORMANCE CURVES FOR HIGH SPEED MODELS

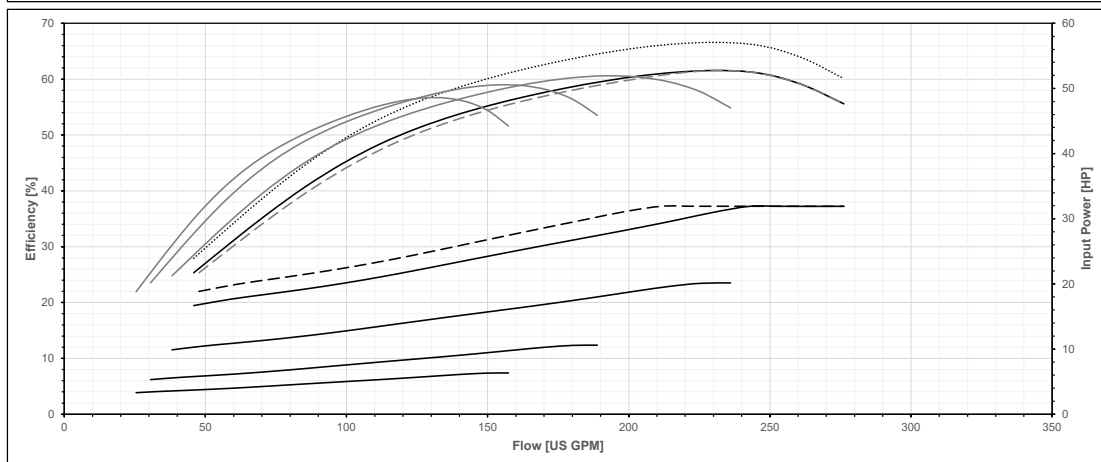
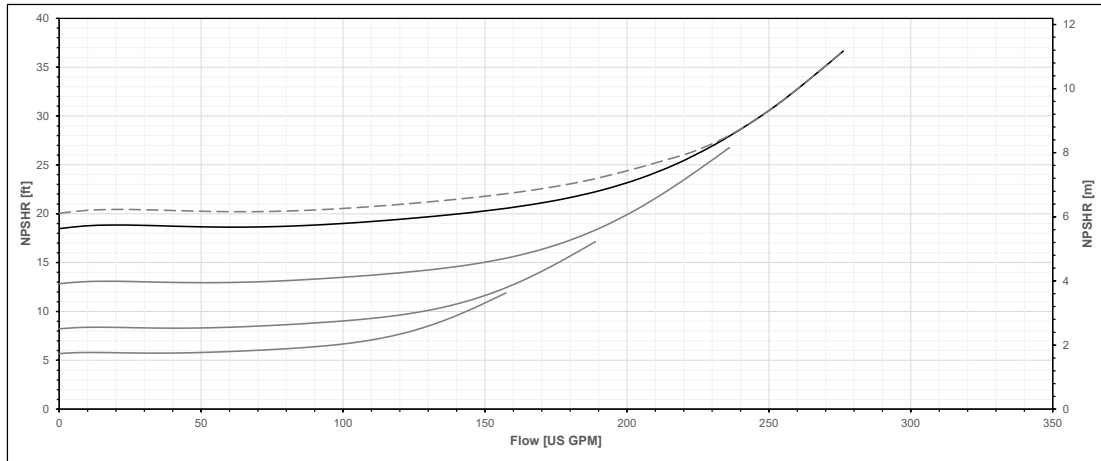
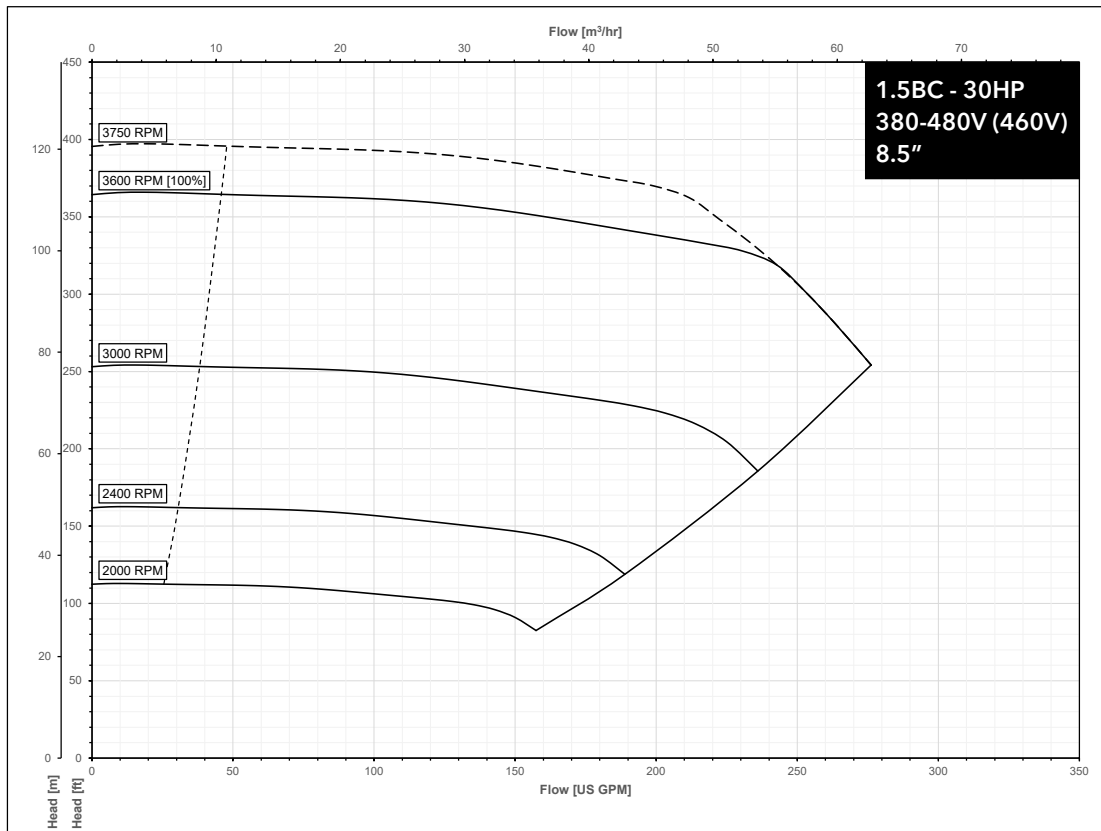

Series e-1531X & e-1532X PERFORMANCE CURVES FOR HIGH SPEED MODELS

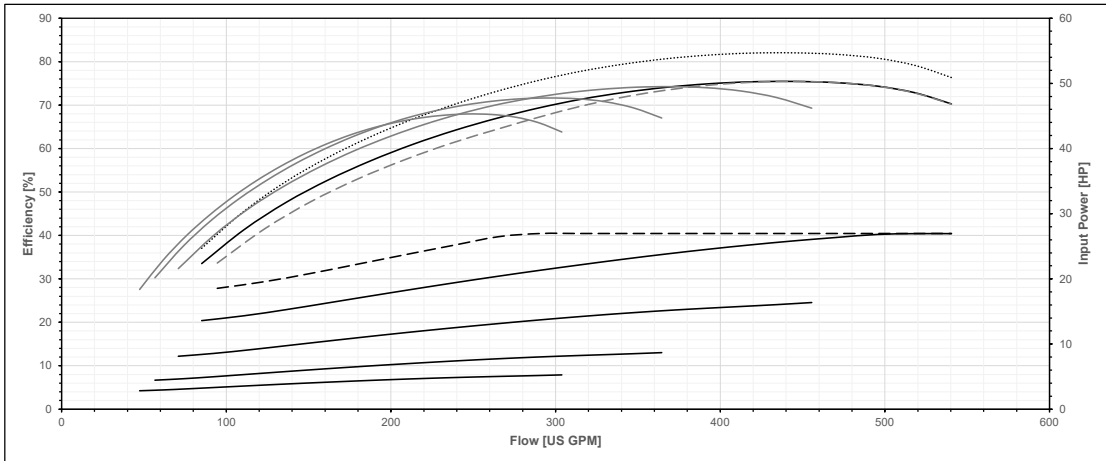
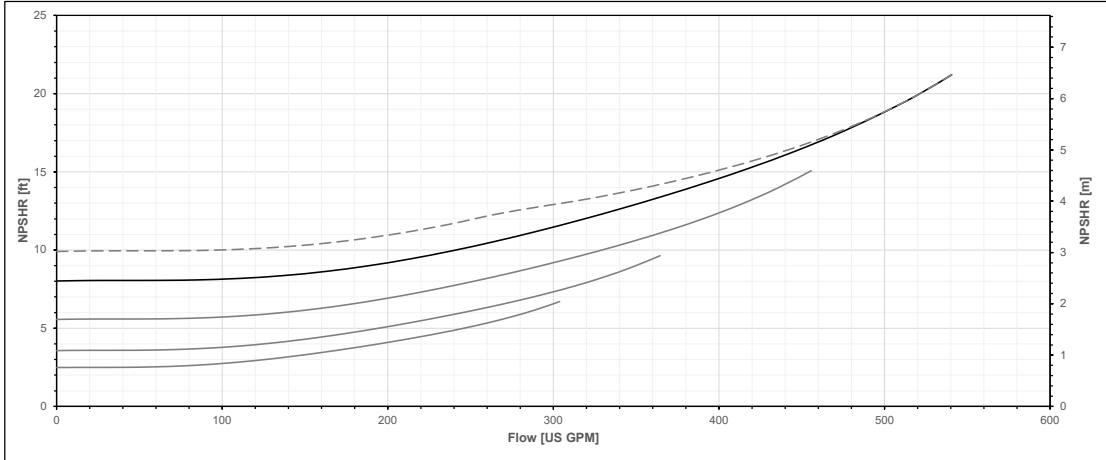
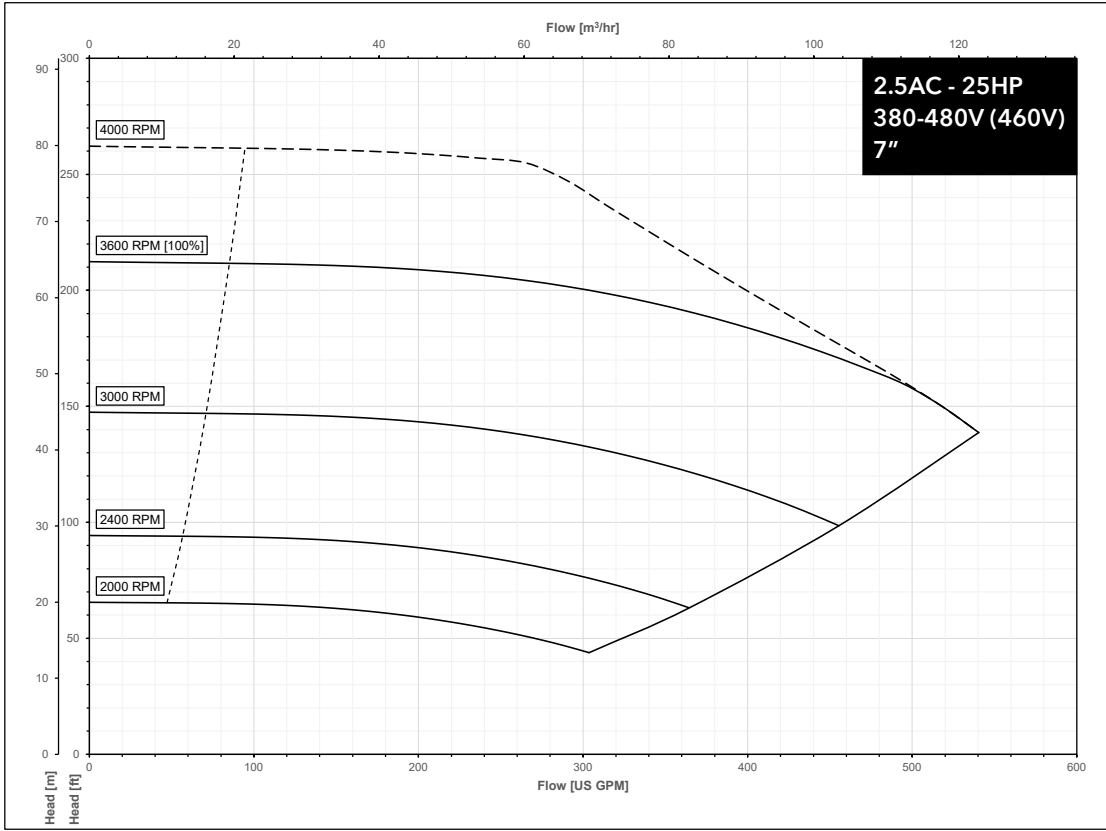



### Series e-1531X & e-1532X PERFORMANCE CURVES FOR HIGH SPEED MODELS

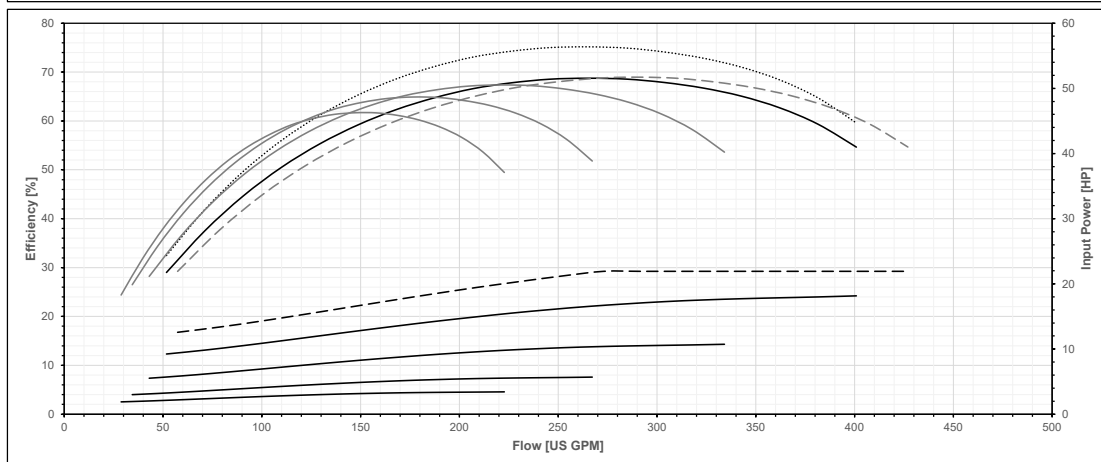
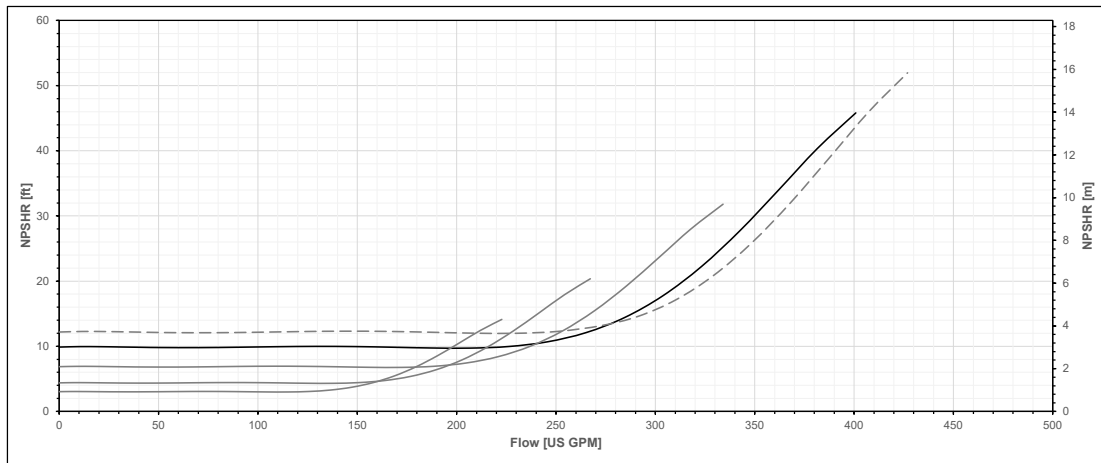
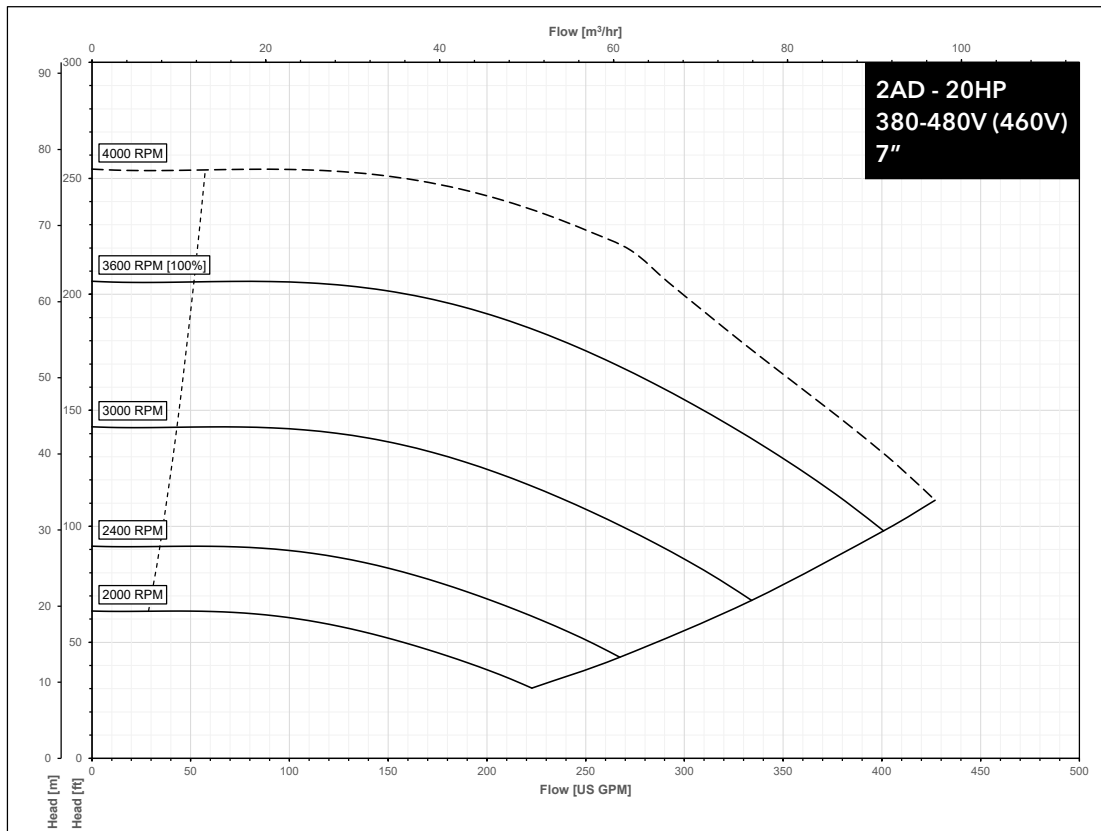

Series e-1531X & e-1532X PERFORMANCE CURVES FOR HIGH SPEED MODELS

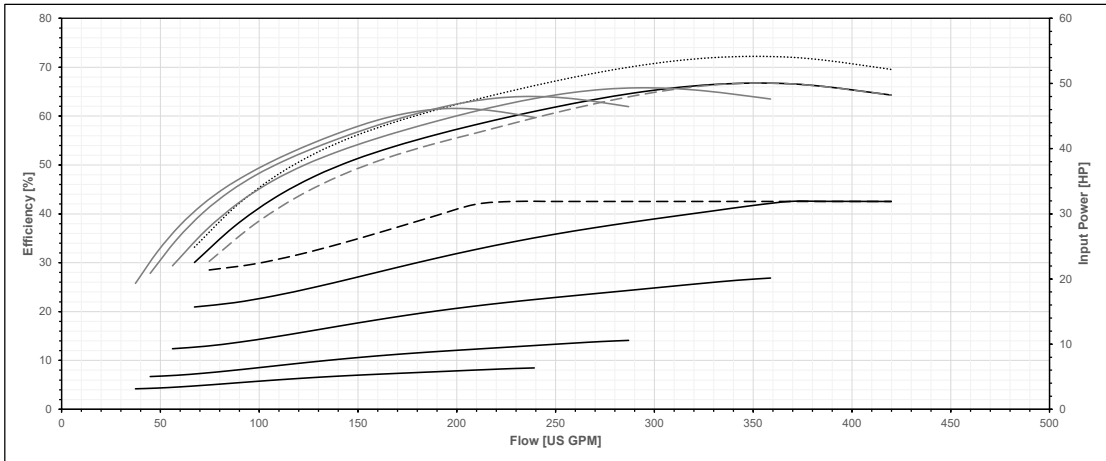
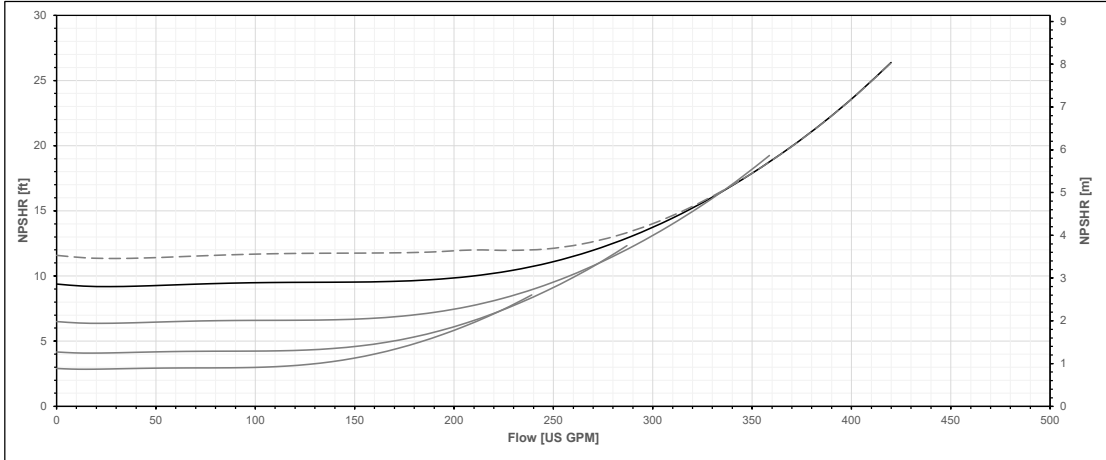
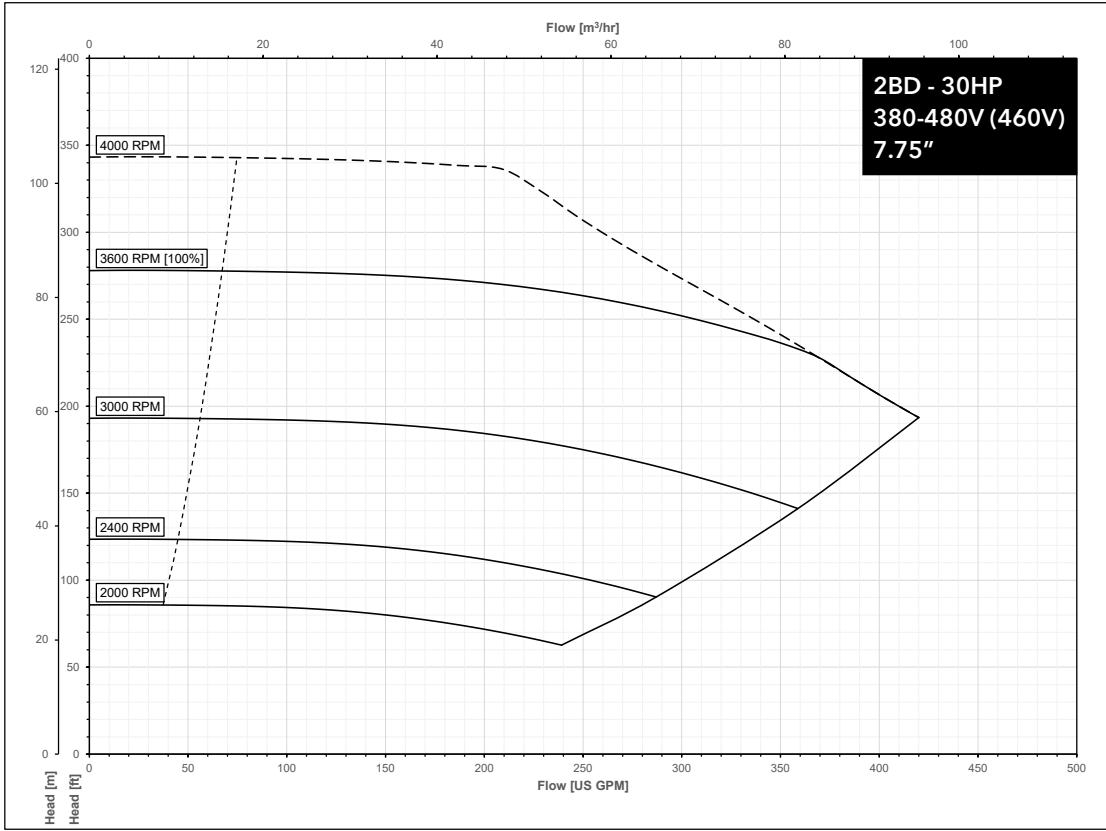

### Series e-1531X & e-1532X PERFORMANCE CURVES FOR HIGH SPEED MODELS

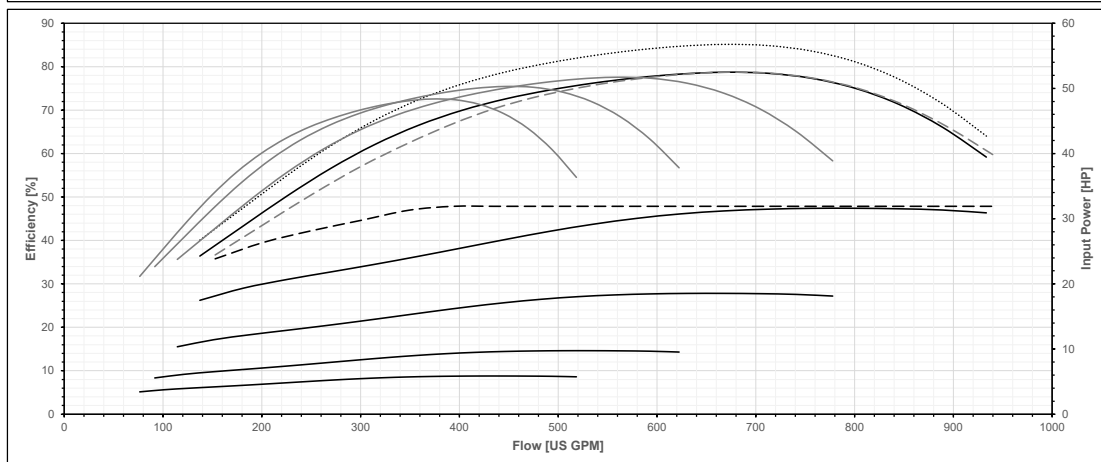
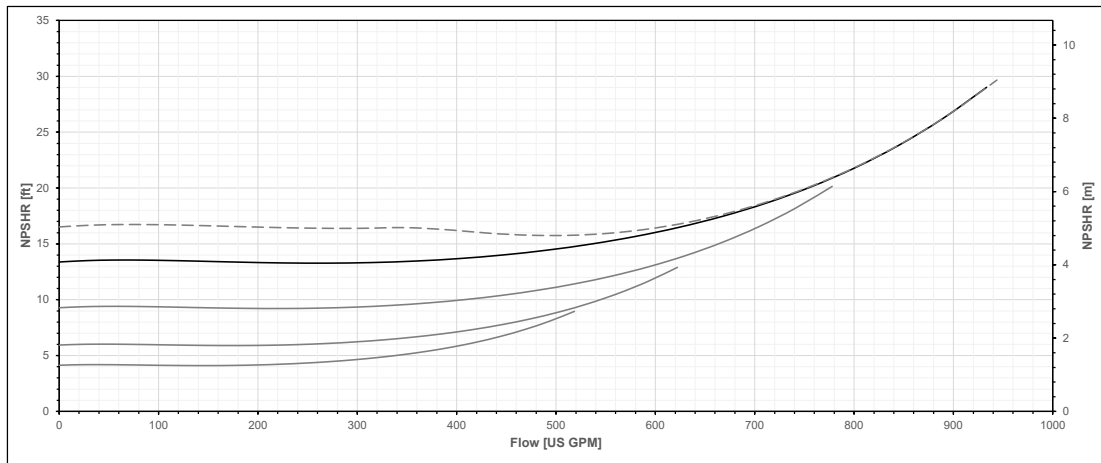
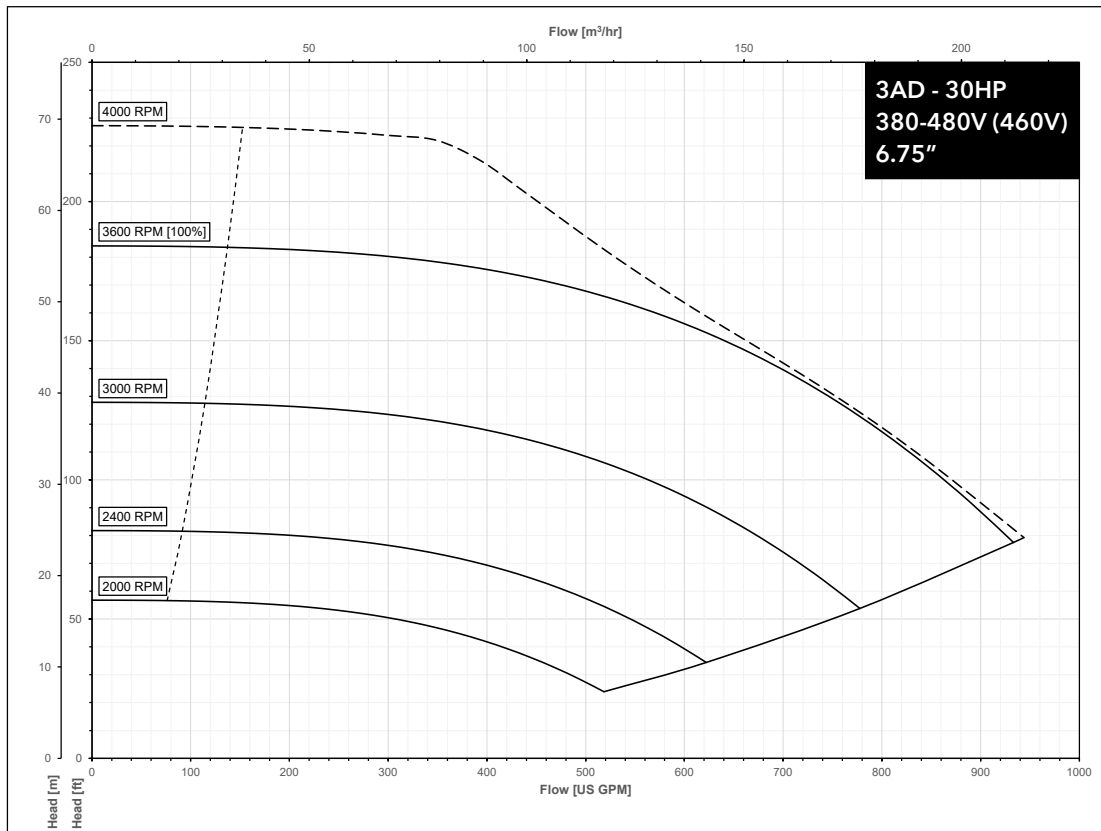

Series e-1531X & e-1532X PERFORMANCE CURVES FOR HIGH SPEED MODELS

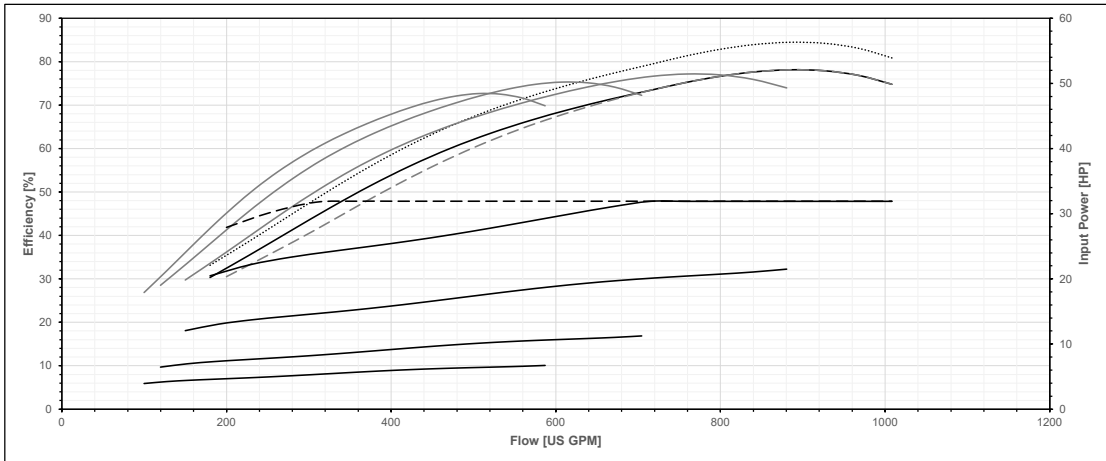
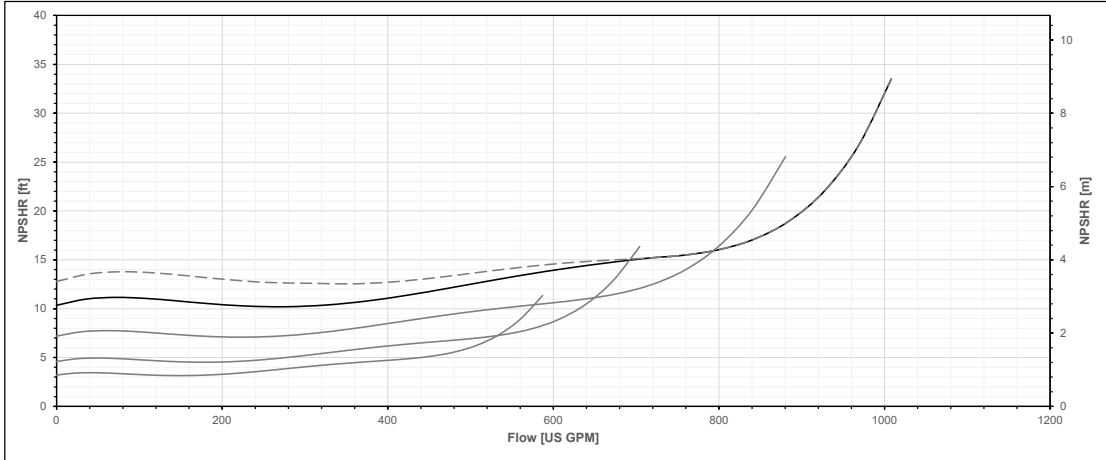
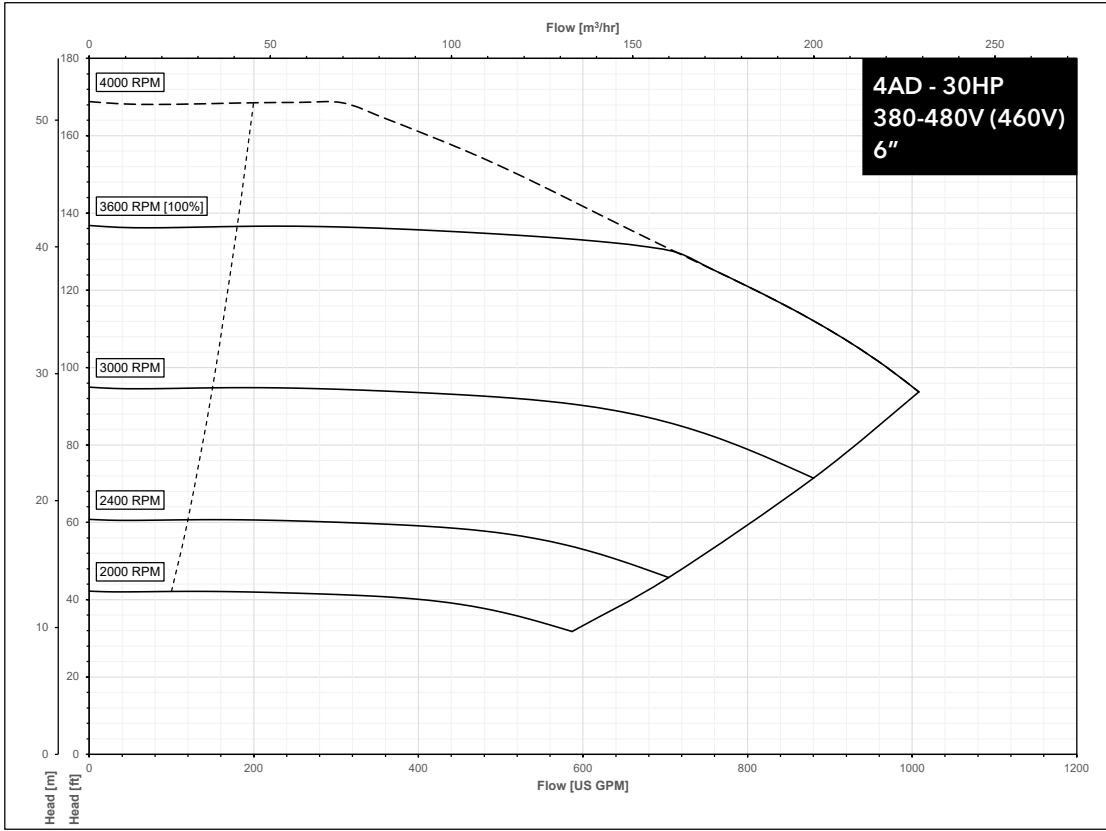

### Series e-1531X & e-1532X PERFORMANCE CURVES FOR HIGH SPEED MODELS

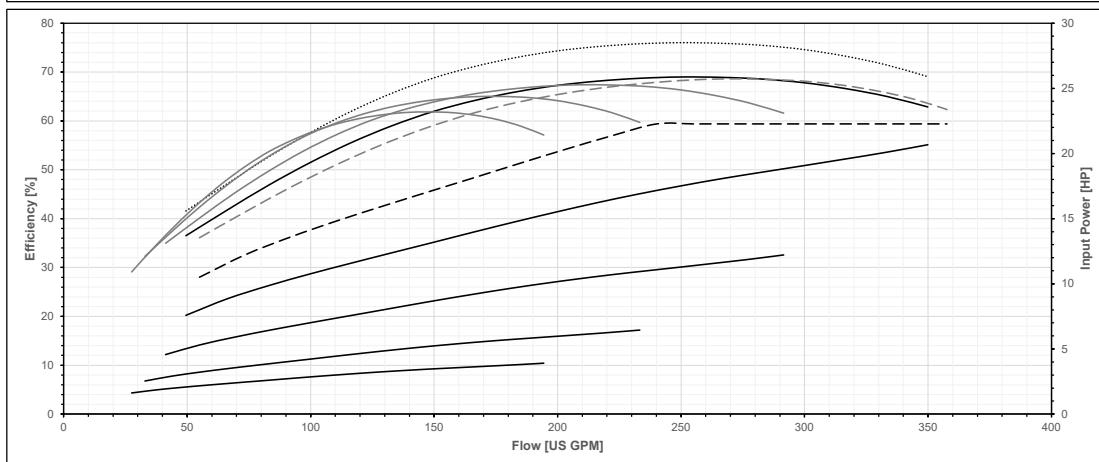
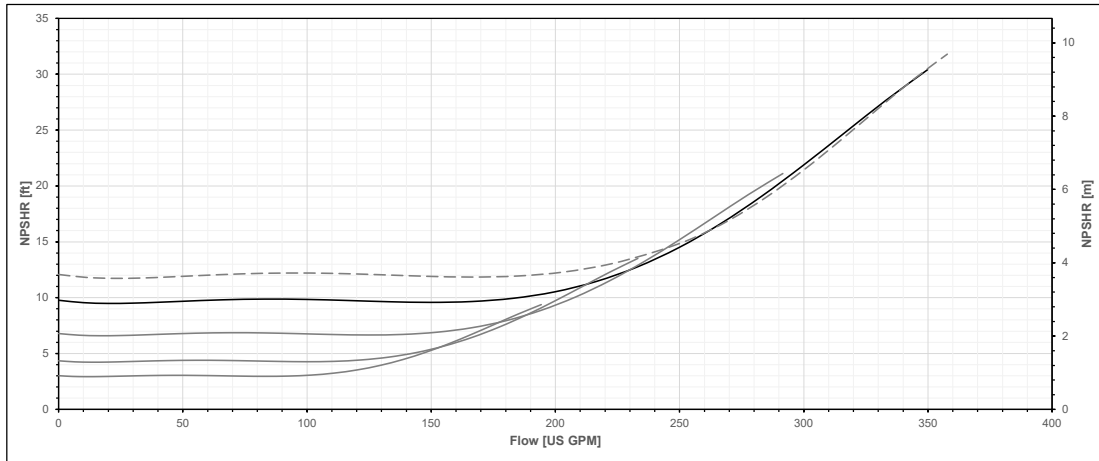
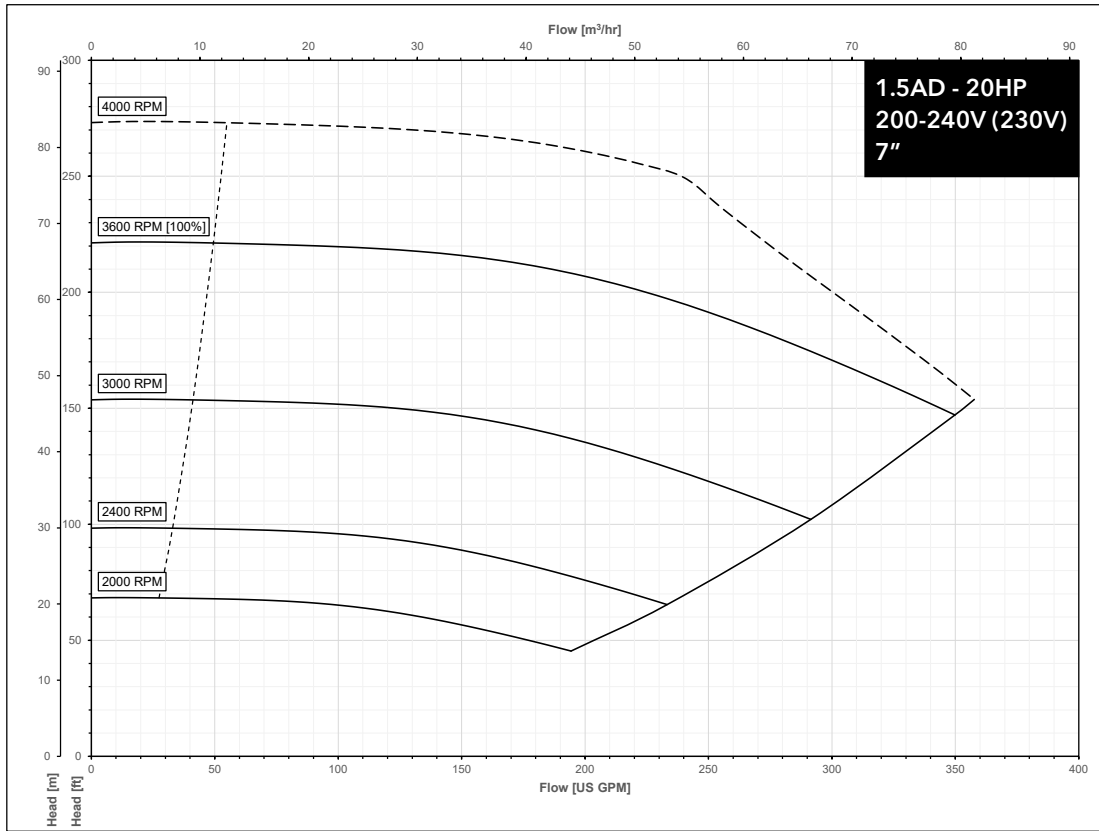

Series e-1531X & e-1532X PERFORMANCE CURVES FOR HIGH SPEED MODELS

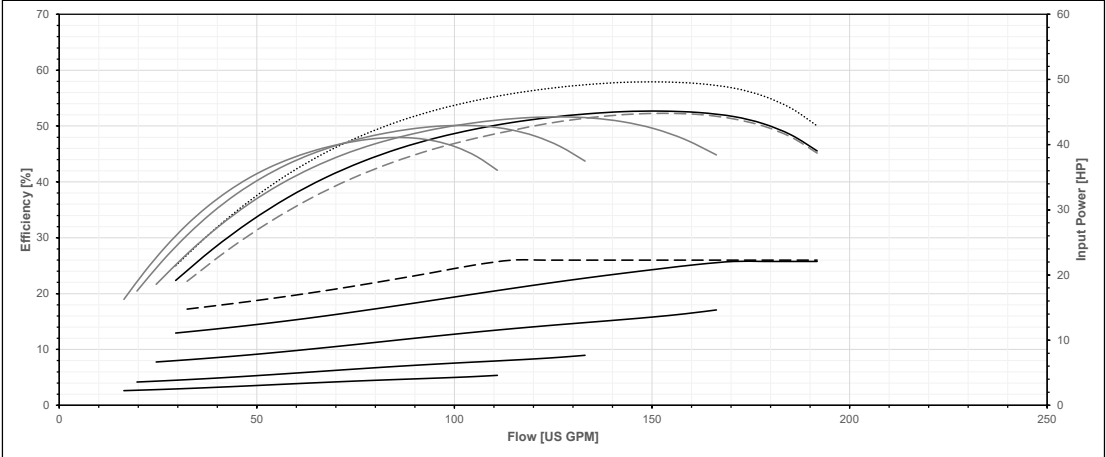
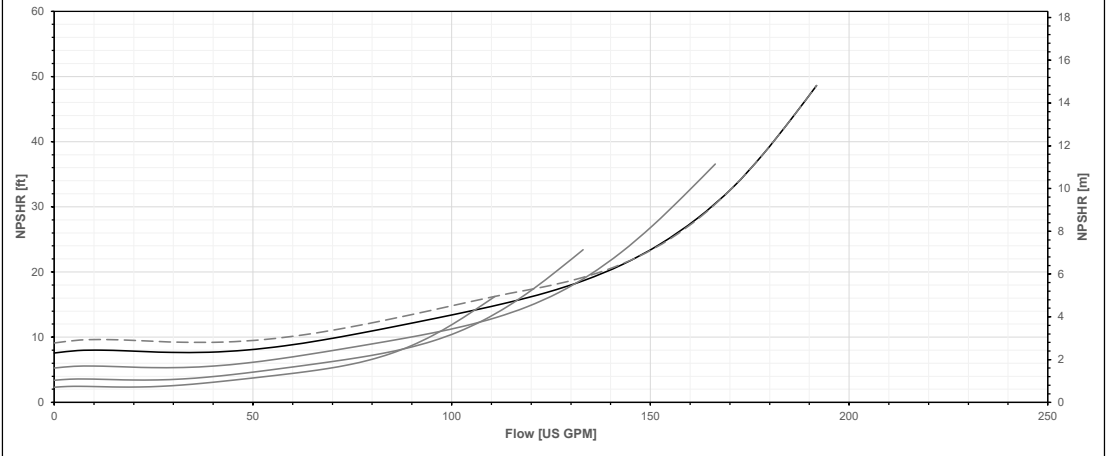
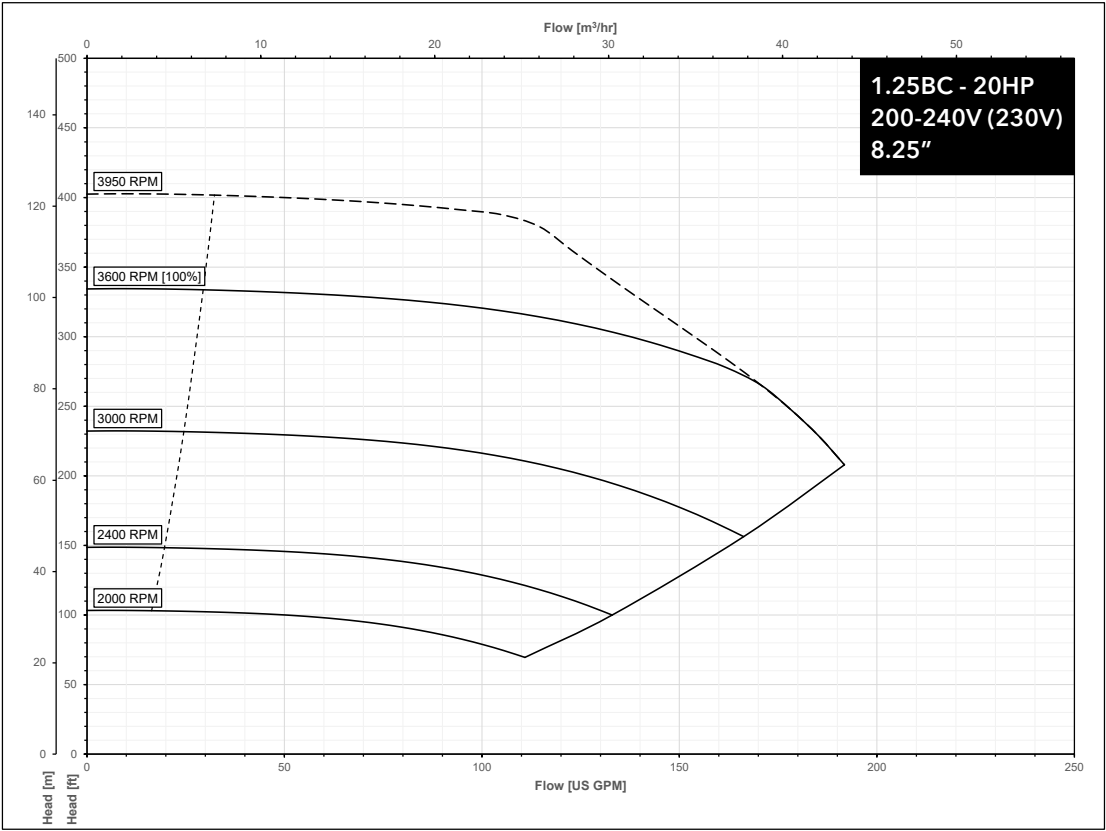

## Series e-1531X & e-1532X PERFORMANCE CURVES FOR HIGH SPEED MODELS

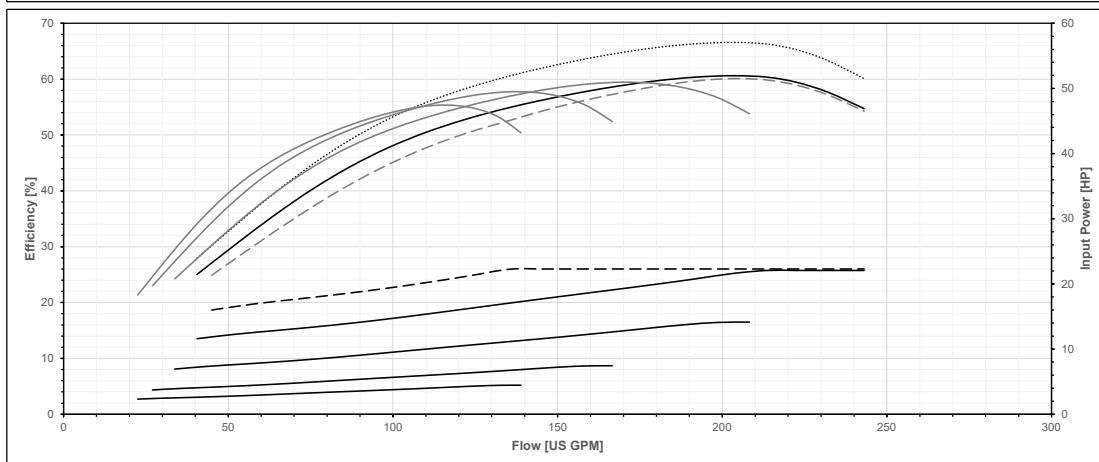
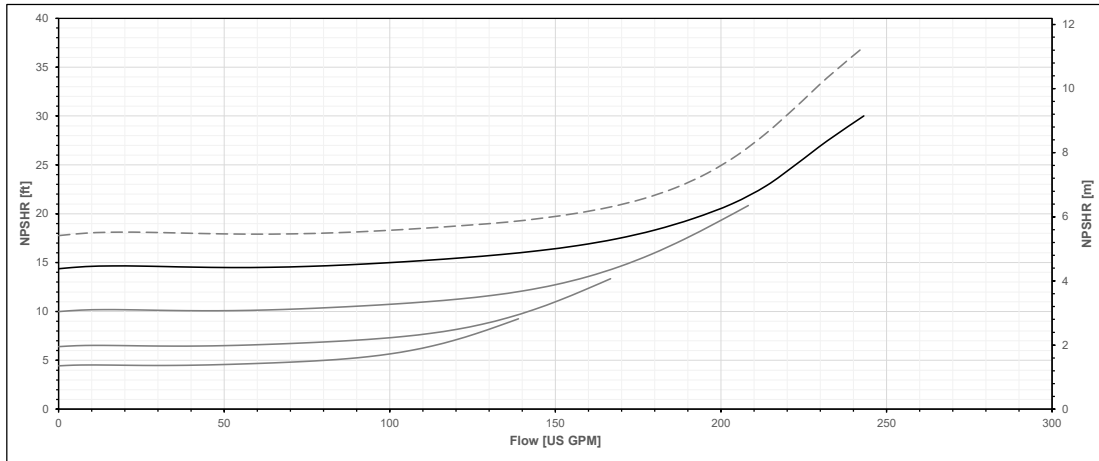
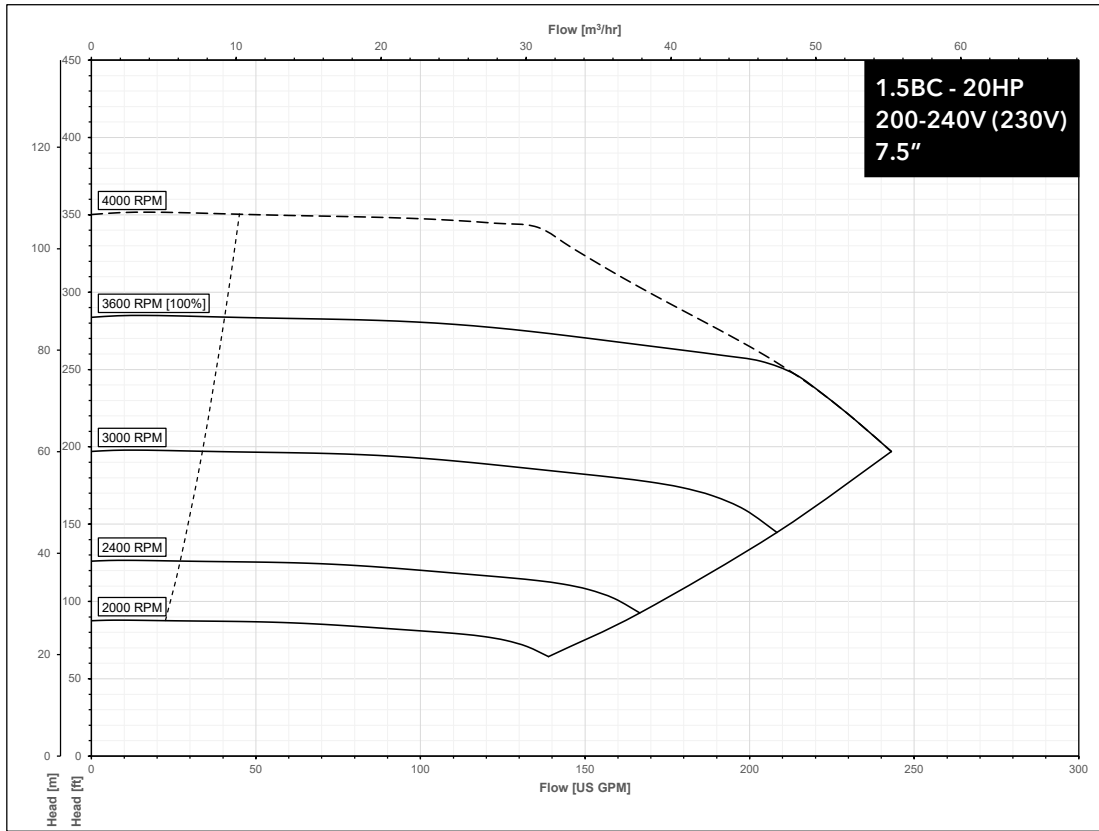

Series e-1531X & e-1532X PERFORMANCE CURVES FOR HIGH SPEED MODELS

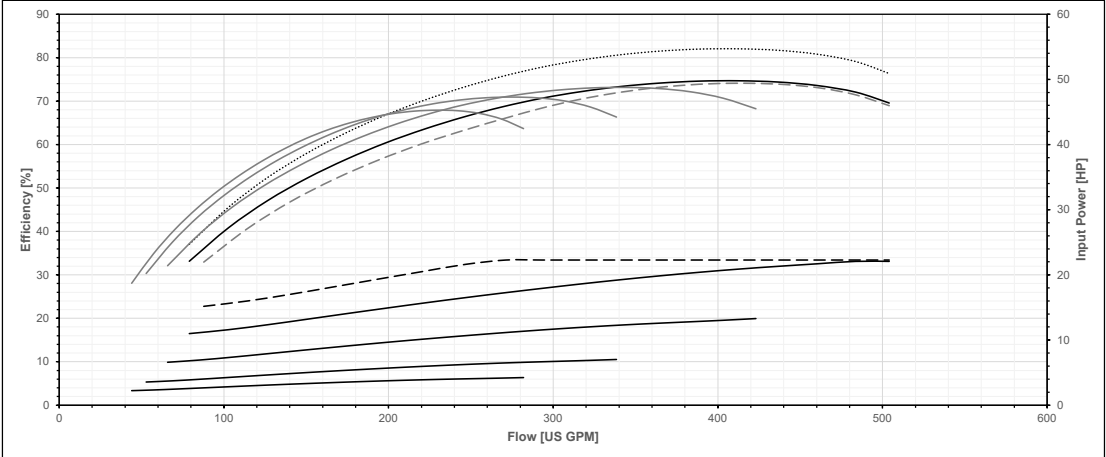
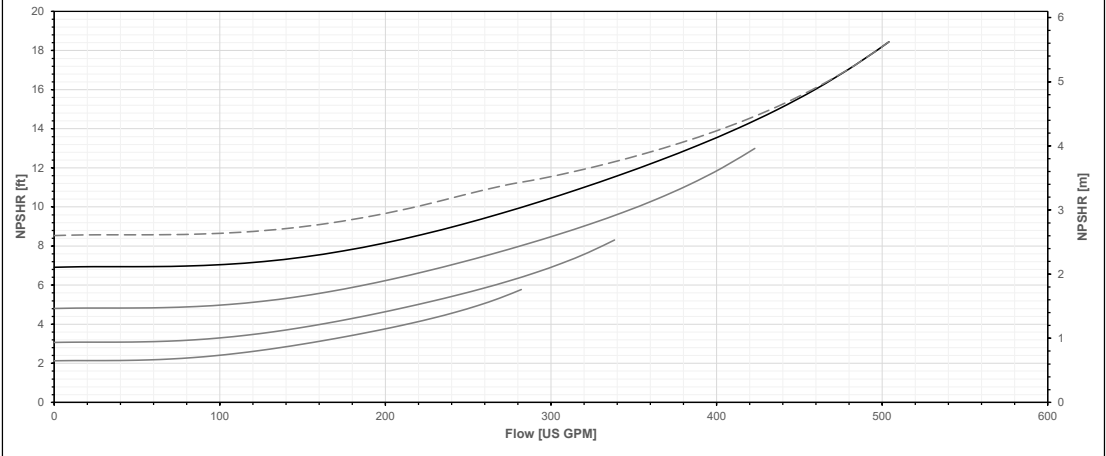
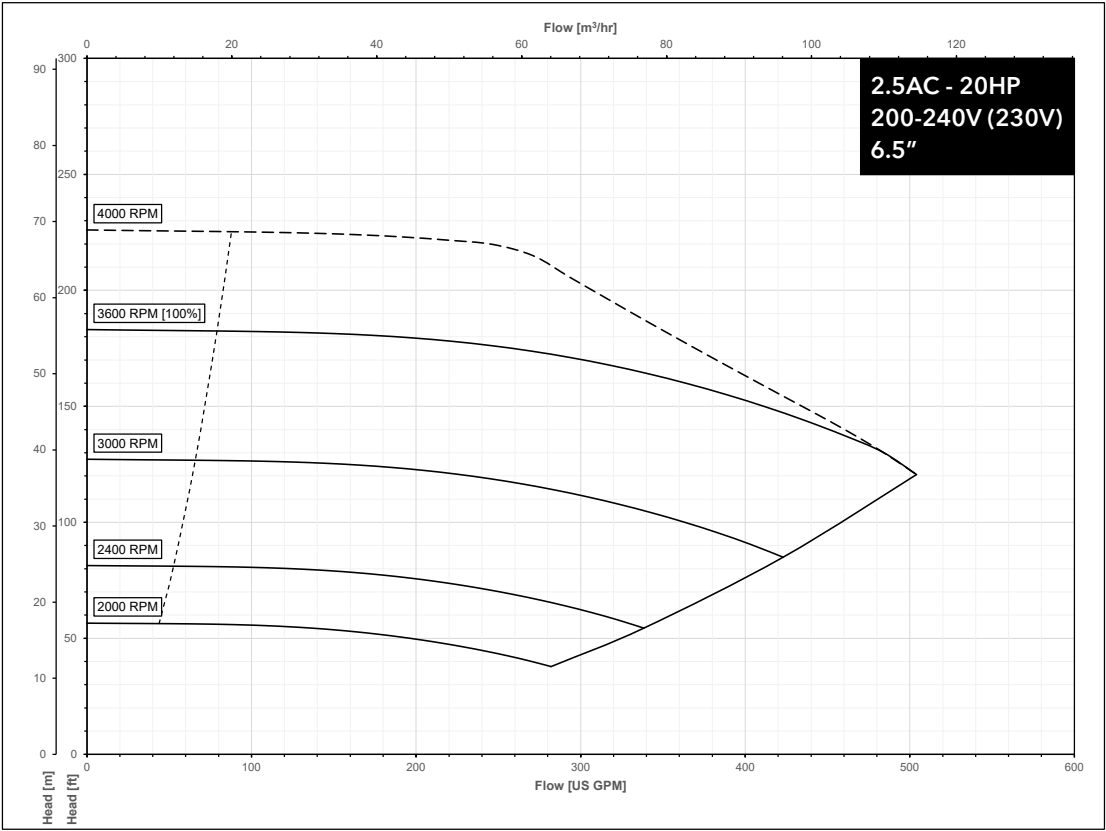



### Series e-1531X & e-1532X PERFORMANCE CURVES FOR HIGH SPEED MODELS

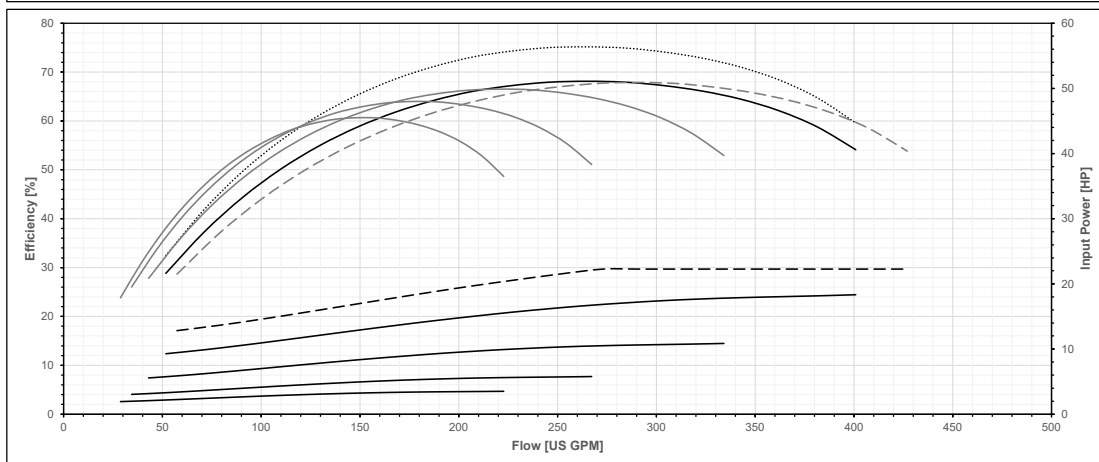
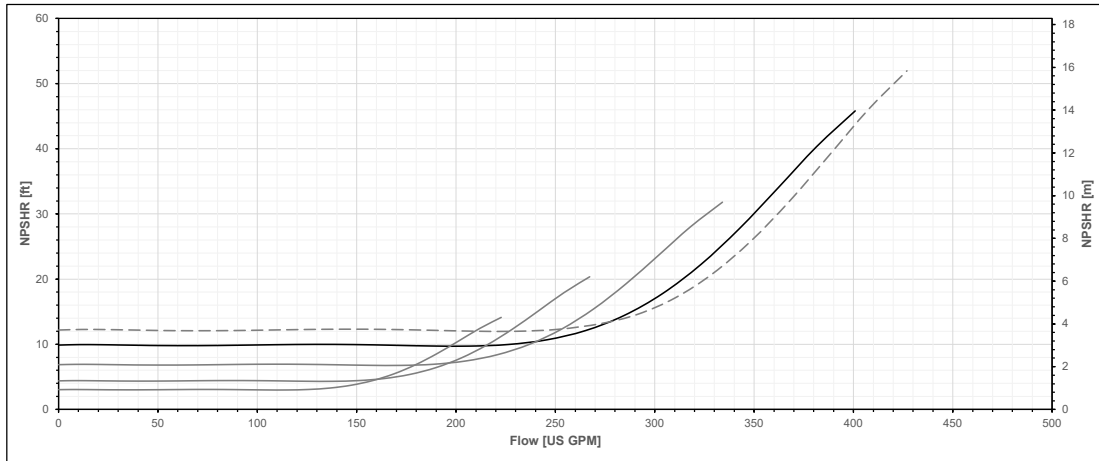
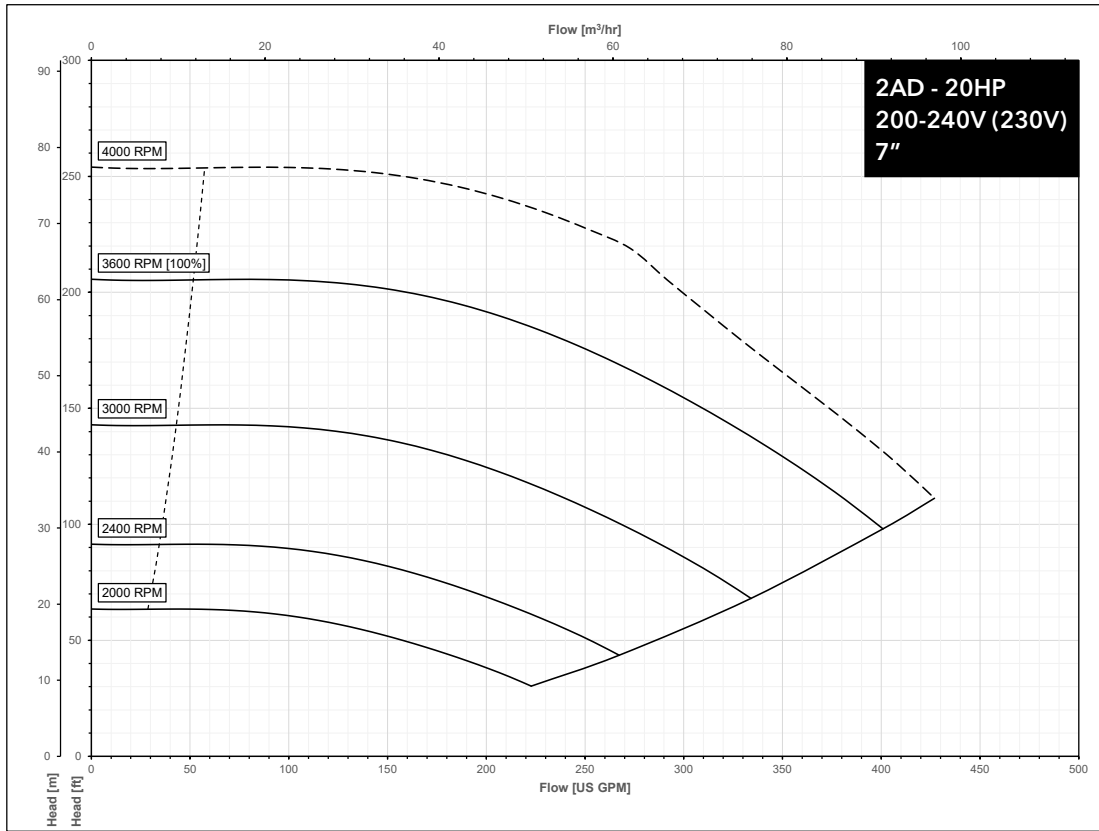

Series e-1531X & e-1532X PERFORMANCE CURVES FOR HIGH SPEED MODELS

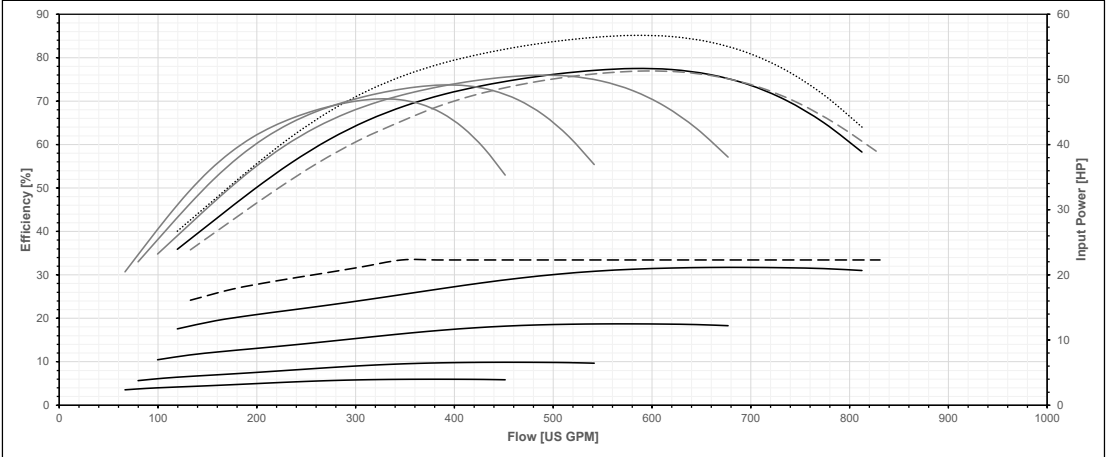
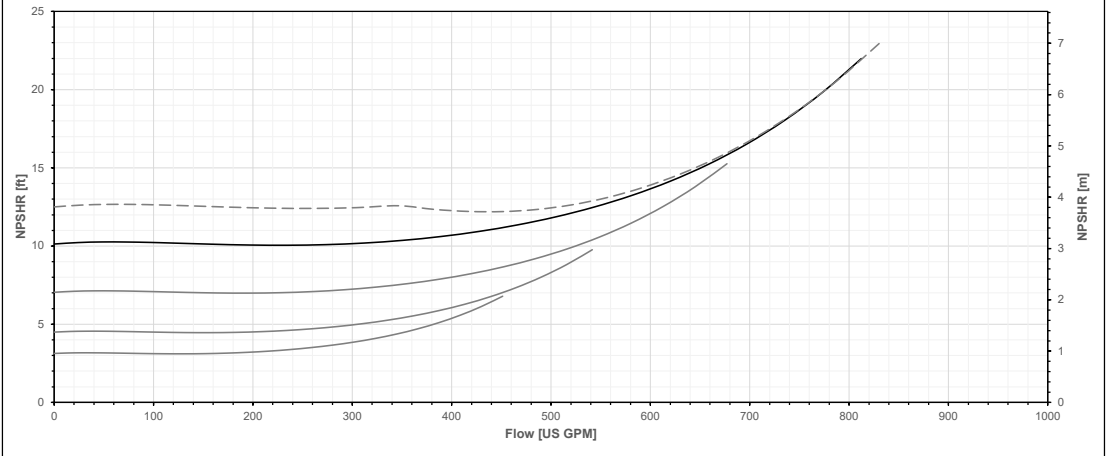
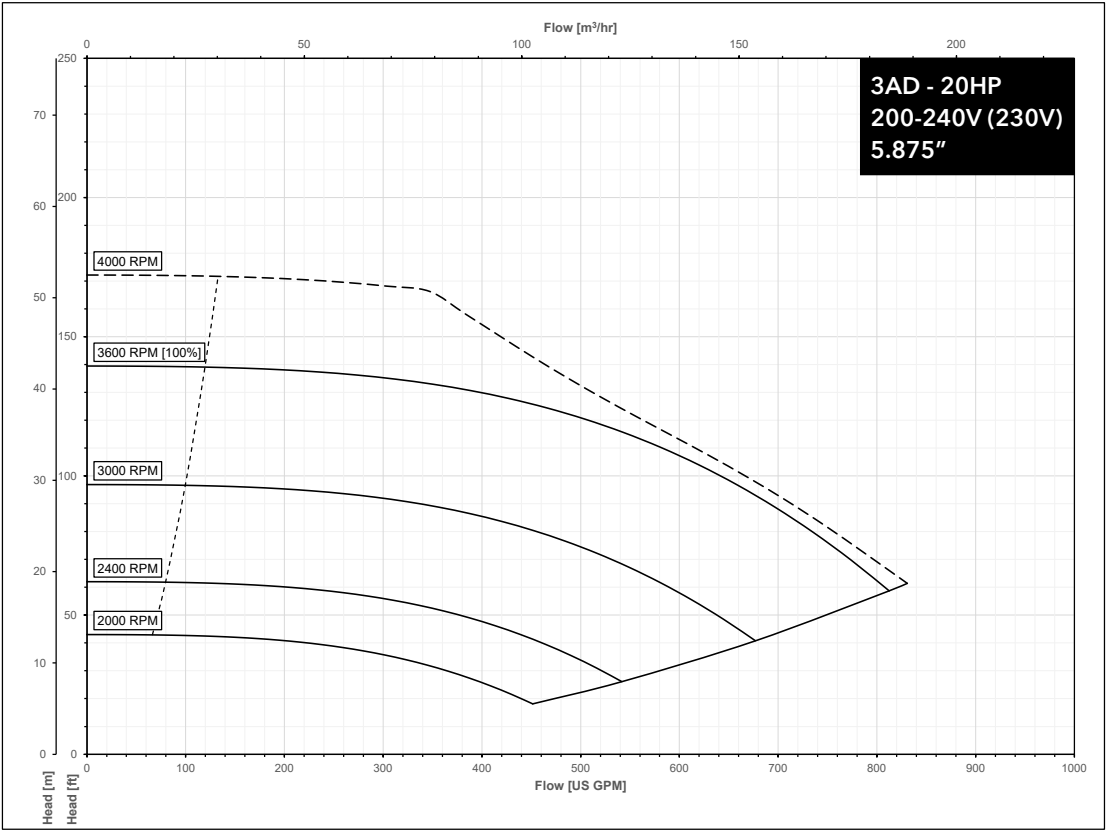

### Series e-1531X & e-1532X PERFORMANCE CURVES FOR HIGH SPEED MODELS

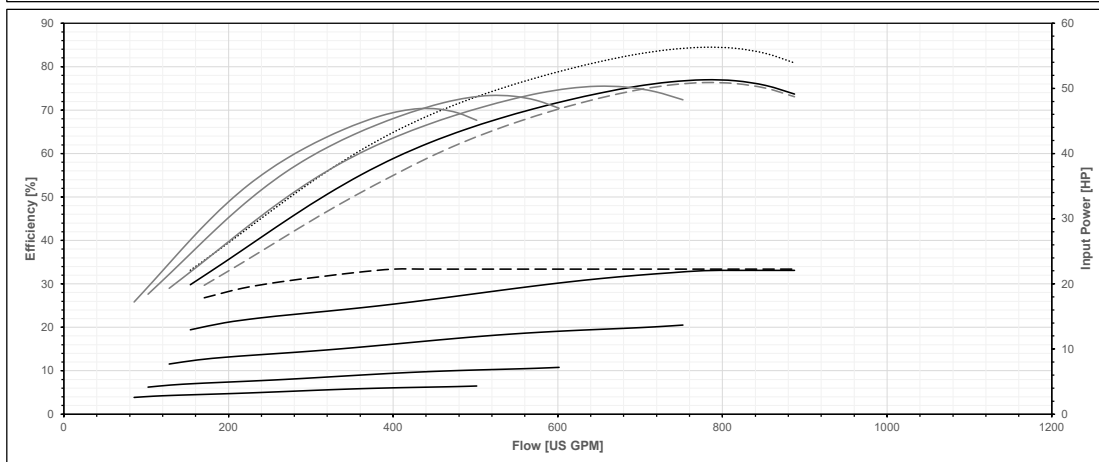
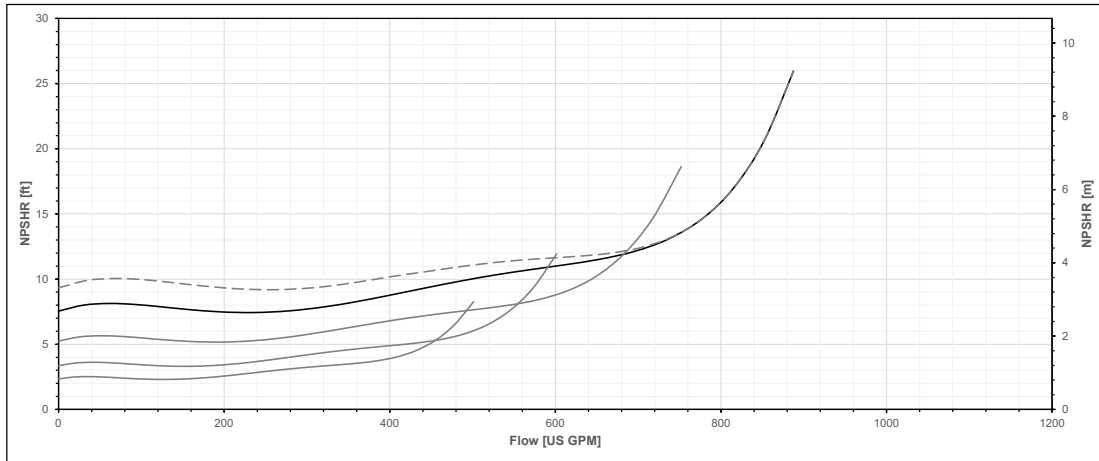
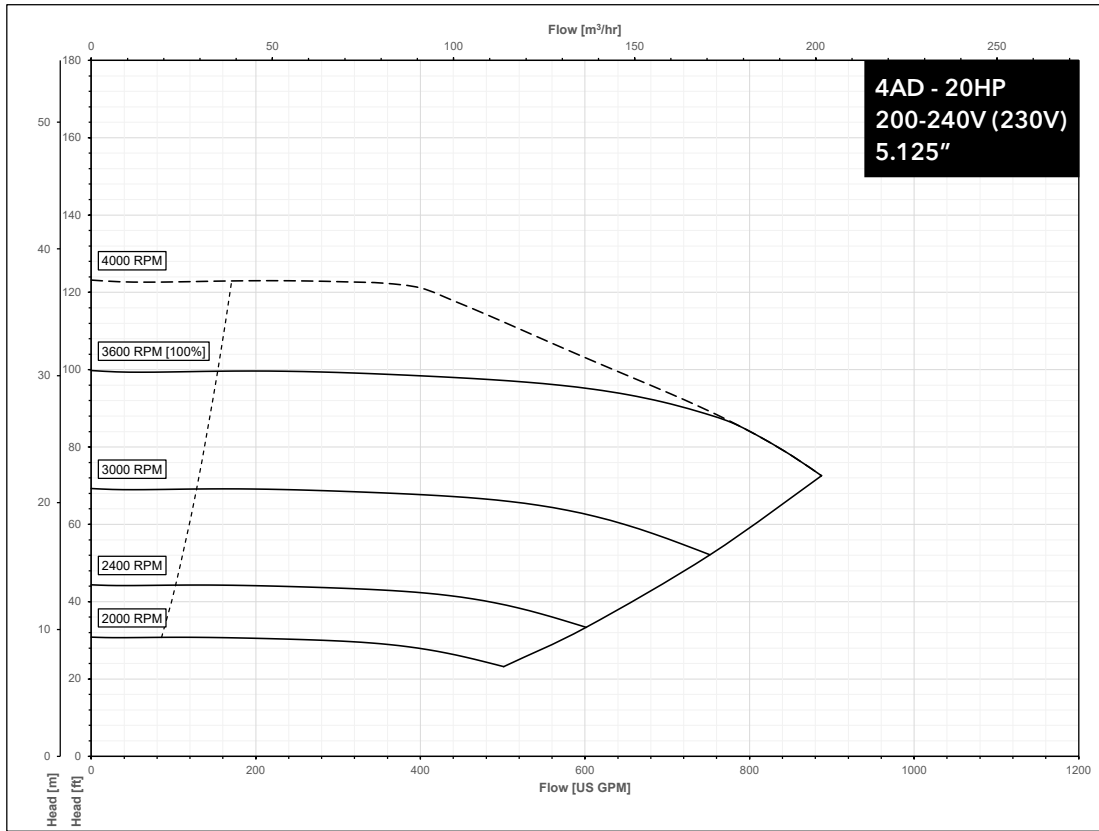

Series e-1531X & e-1532X PERFORMANCE CURVES FOR LOW SPEED MODELS

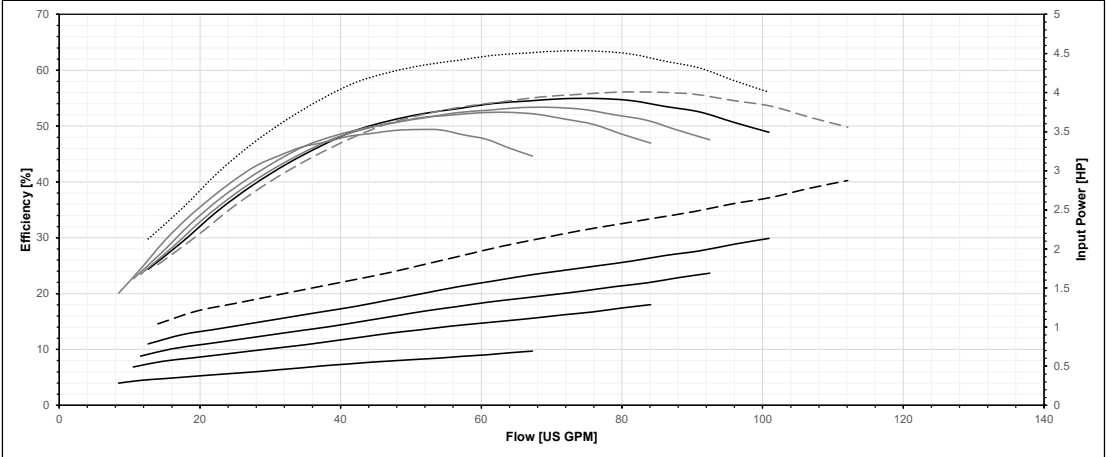
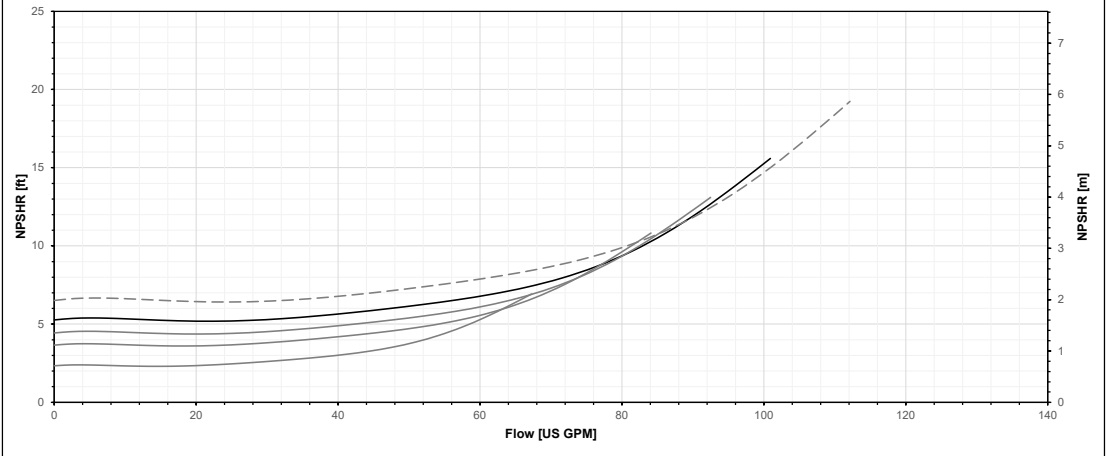
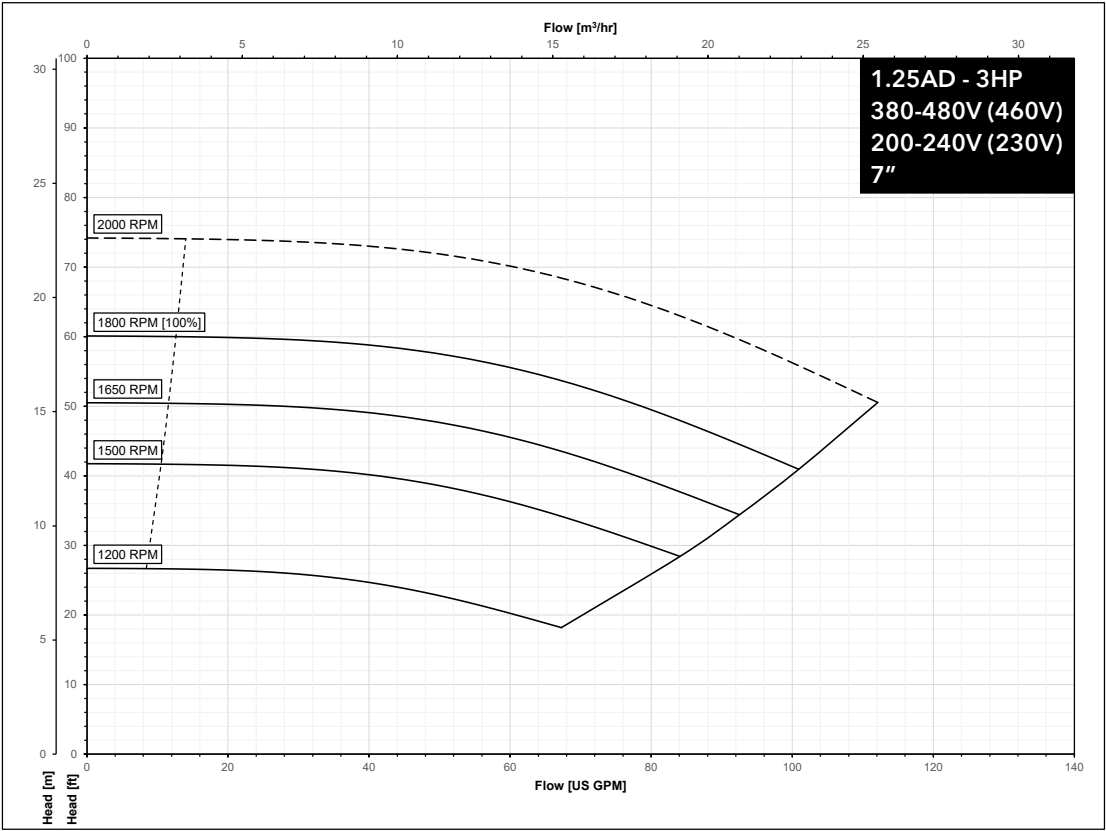

### Series e-1531X & e-1532X PERFORMANCE CURVES FOR LOW SPEED MODELS

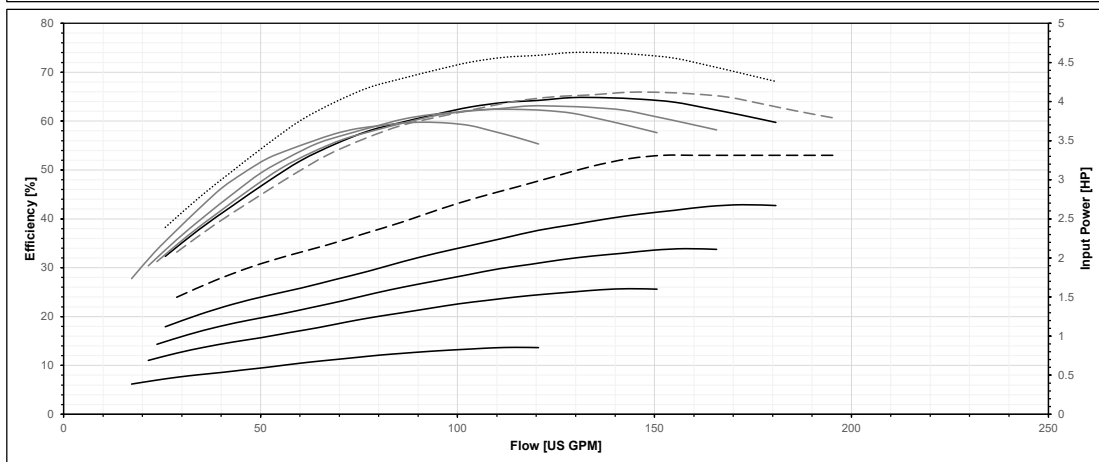
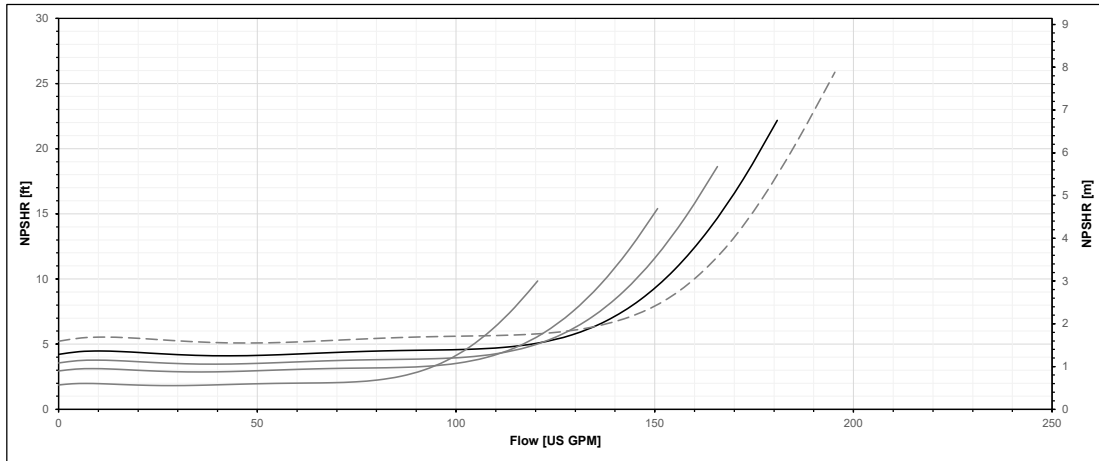
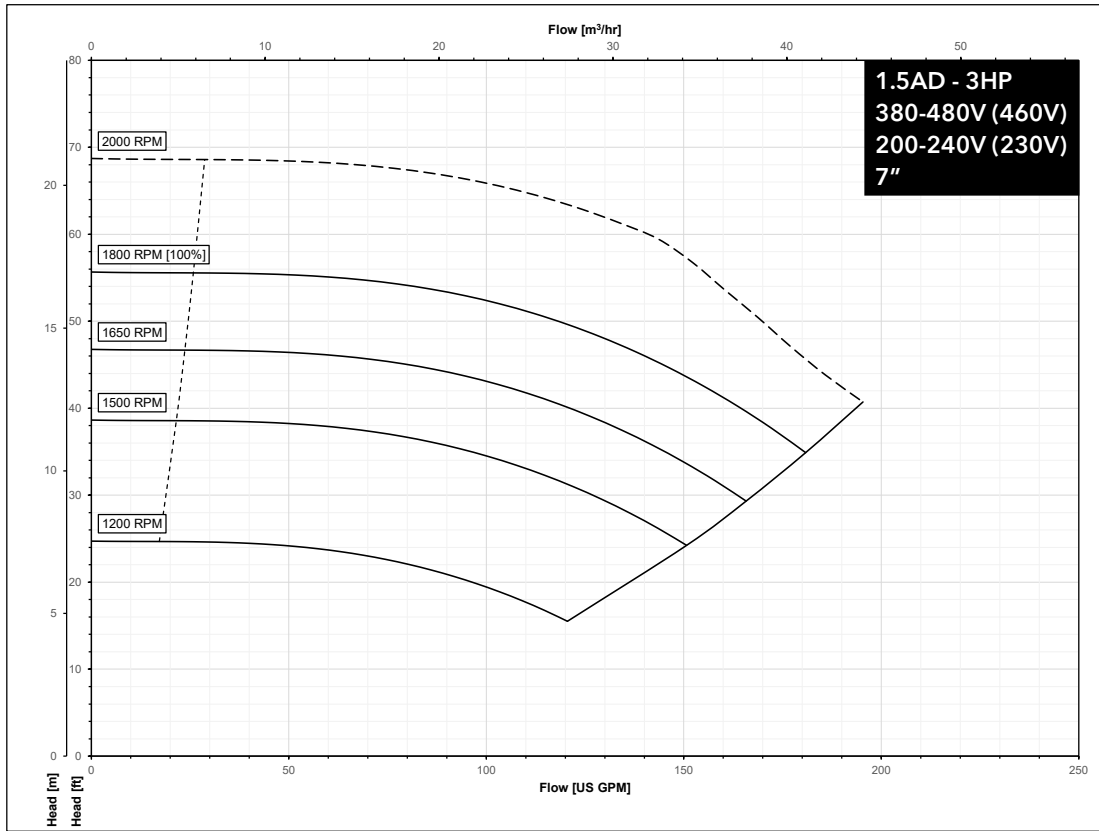

Series e-1531X & e-1532X PERFORMANCE CURVES FOR LOW SPEED MODELS

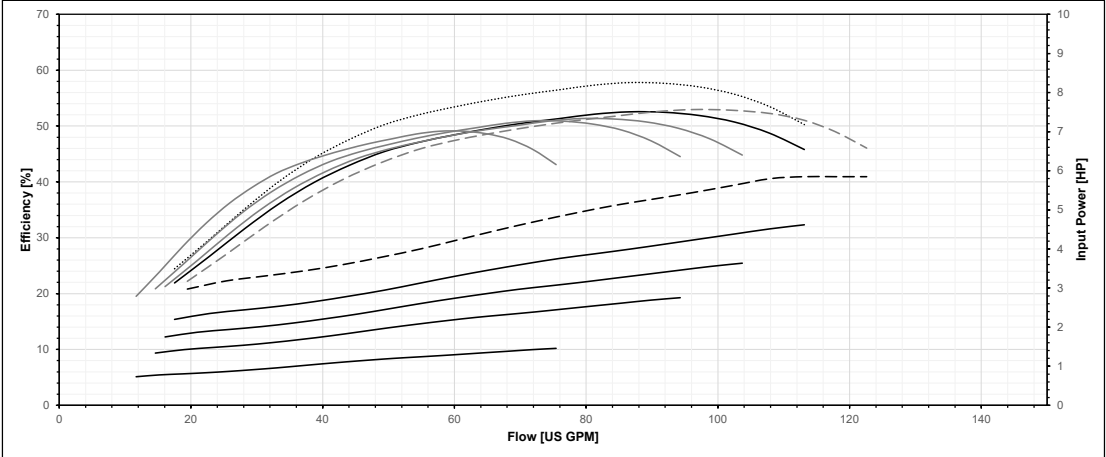
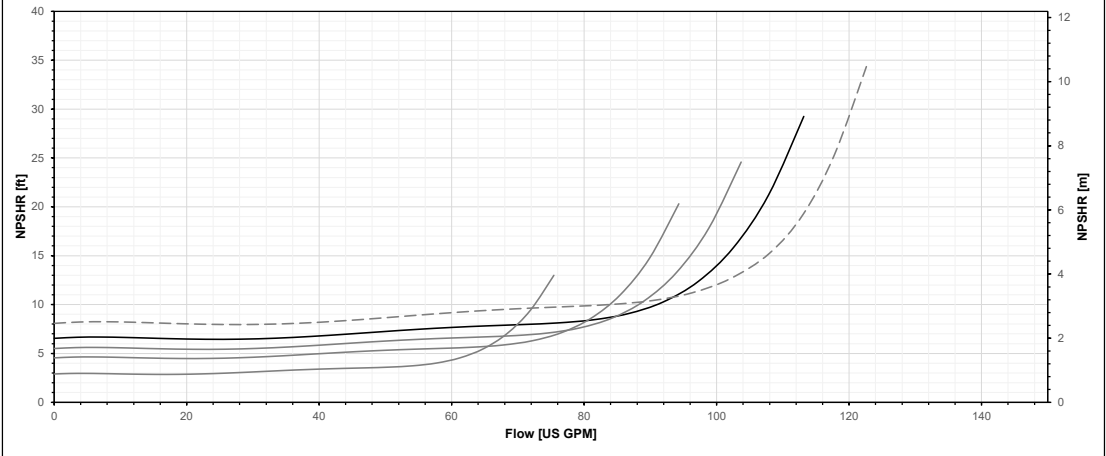
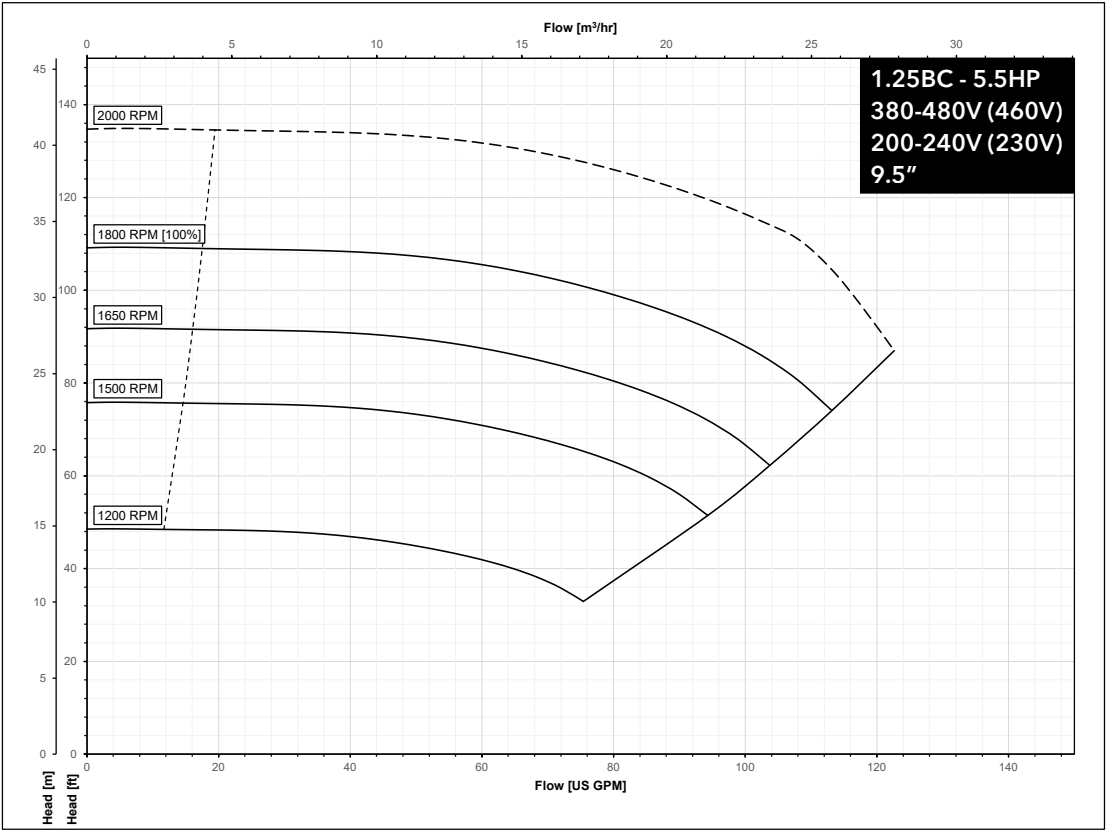

### Series e-1531X & e-1532X PERFORMANCE CURVES FOR LOW SPEED MODELS

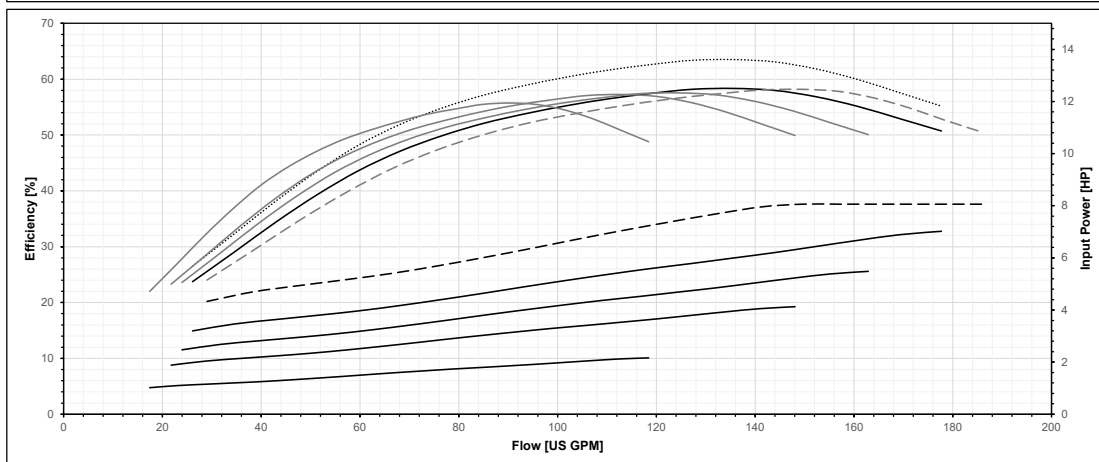
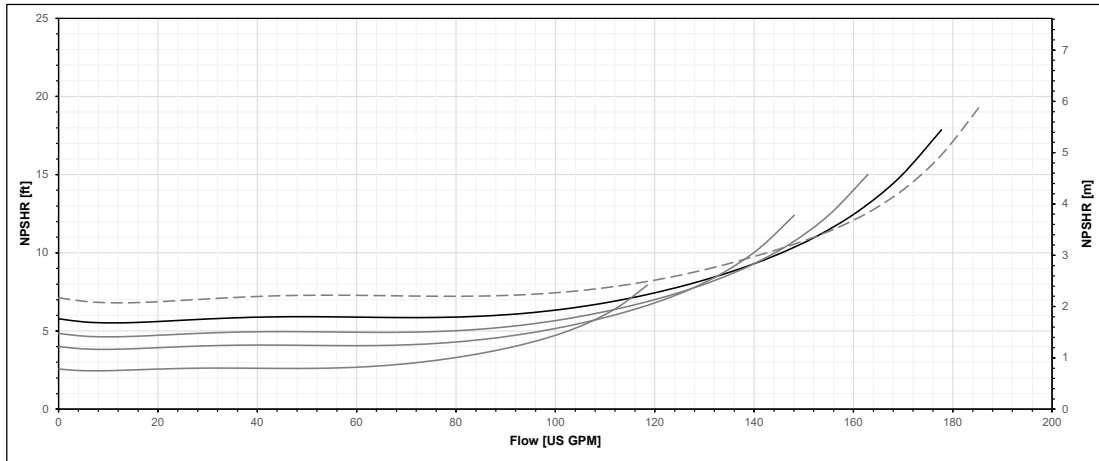
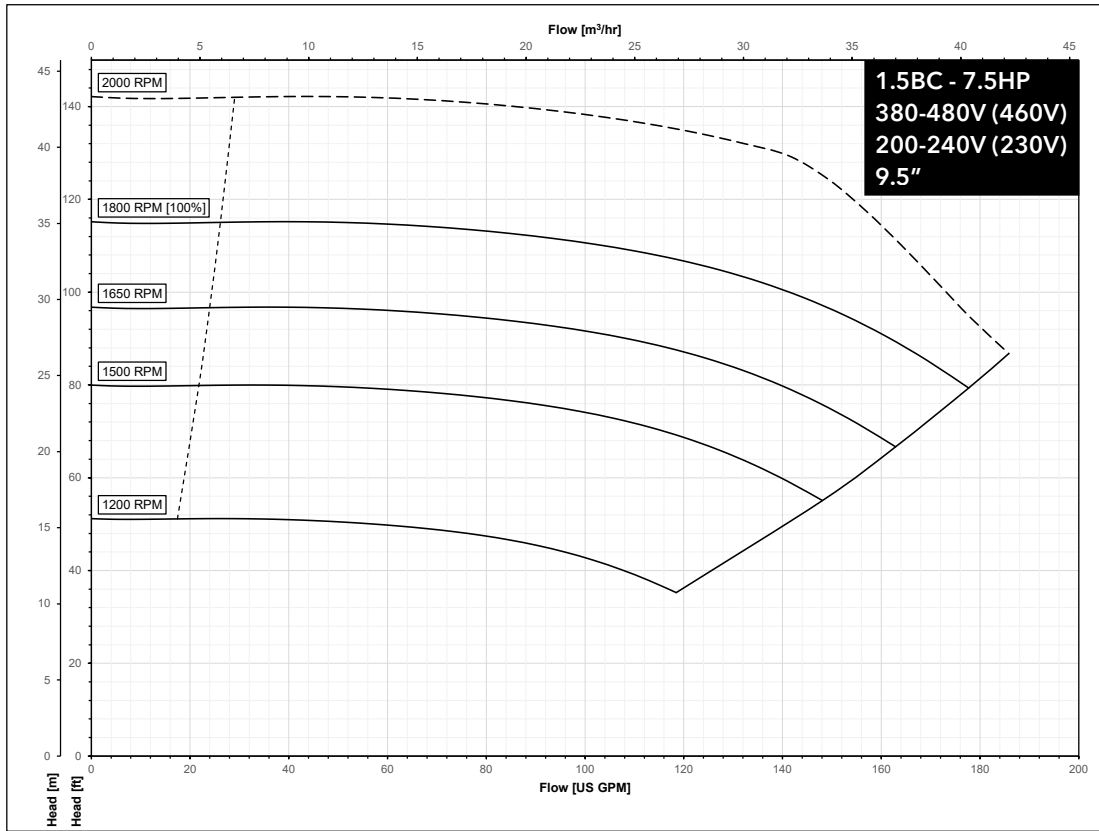

Series e-1531X & e-1532X PERFORMANCE CURVES FOR LOW SPEED MODELS

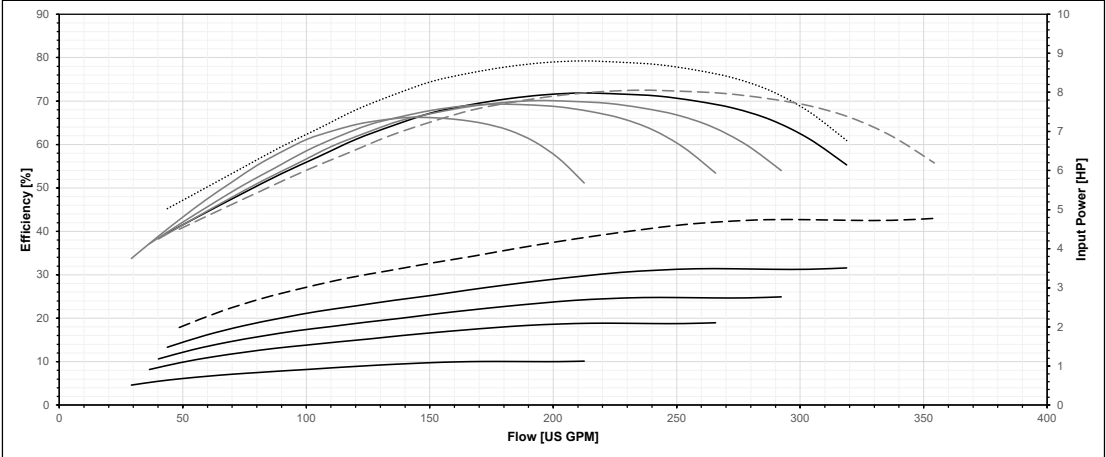
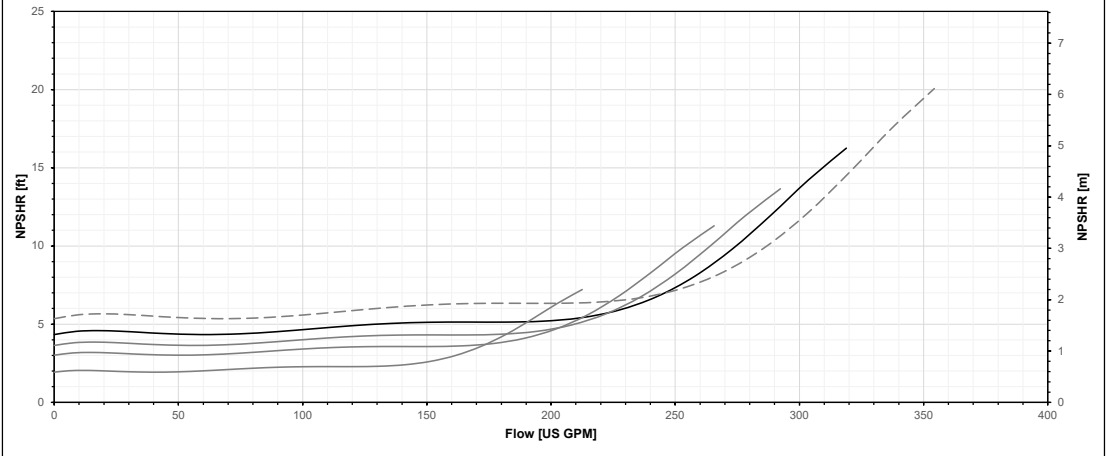
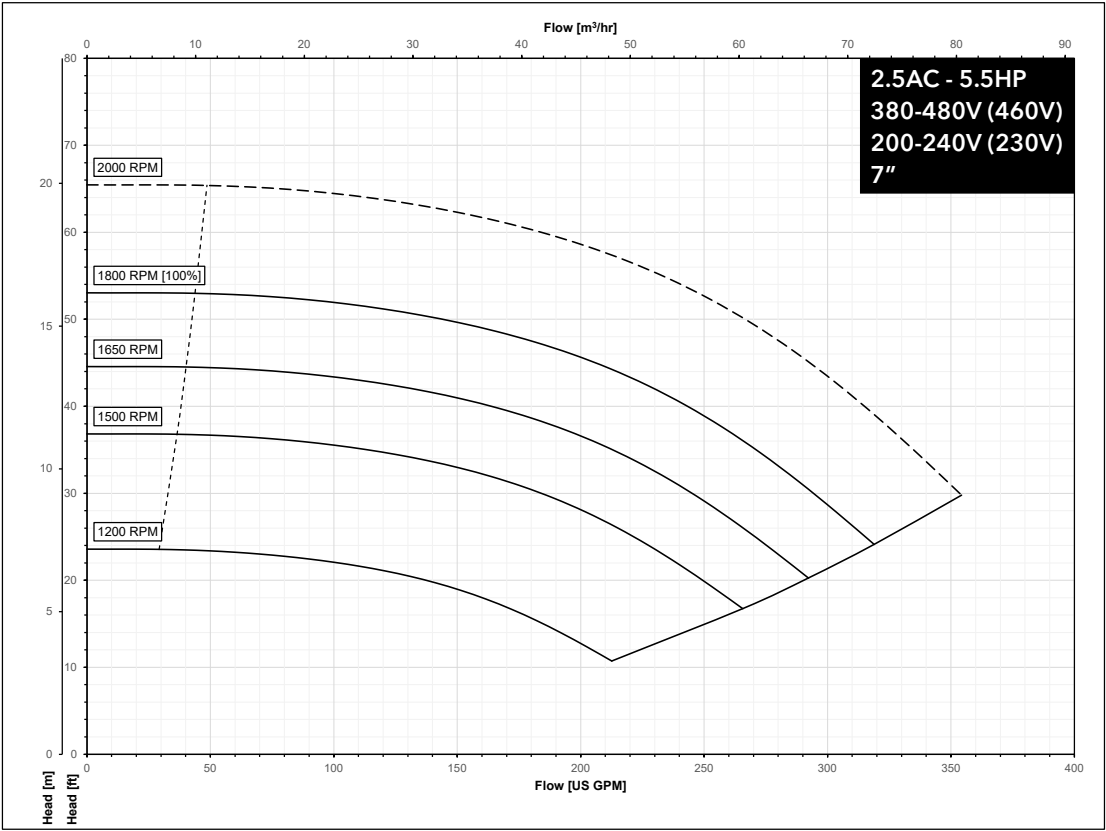



### Series e-1531X & e-1532X PERFORMANCE CURVES FOR LOW SPEED MODELS

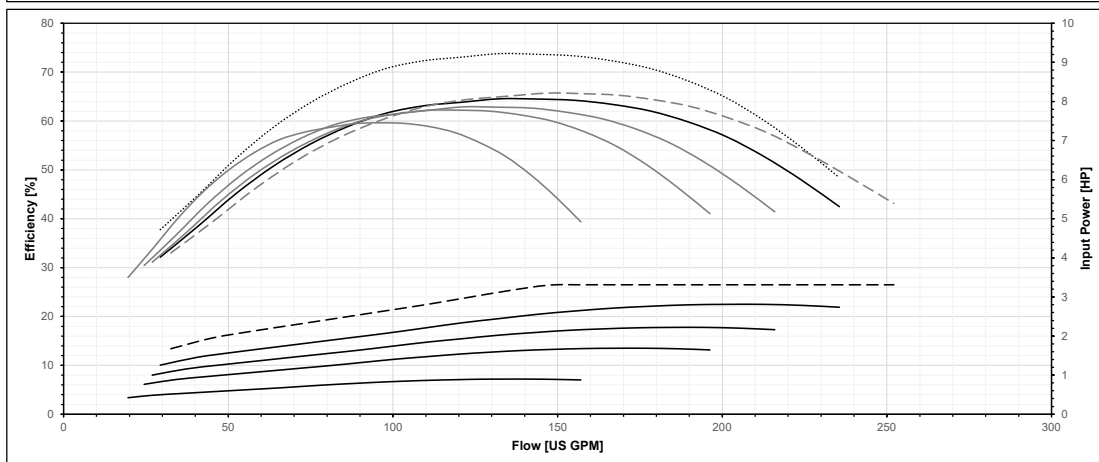
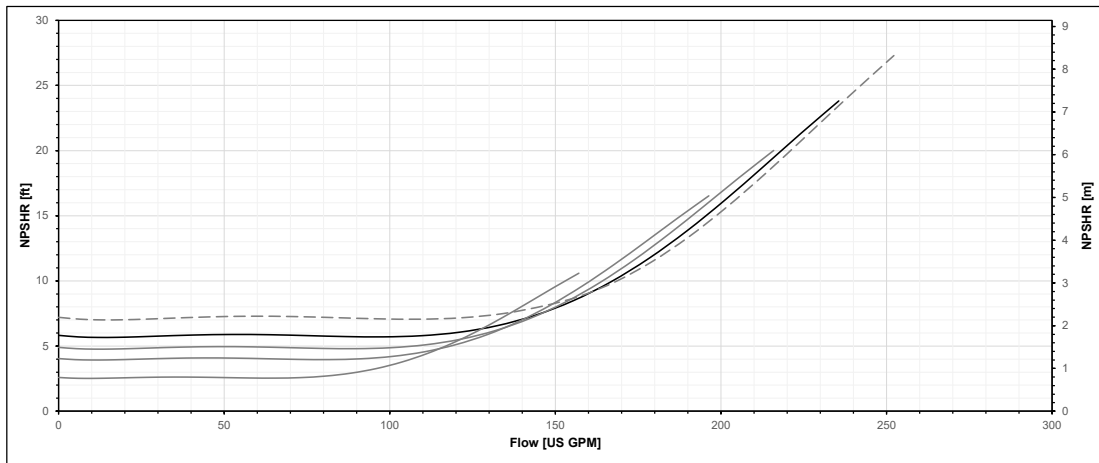
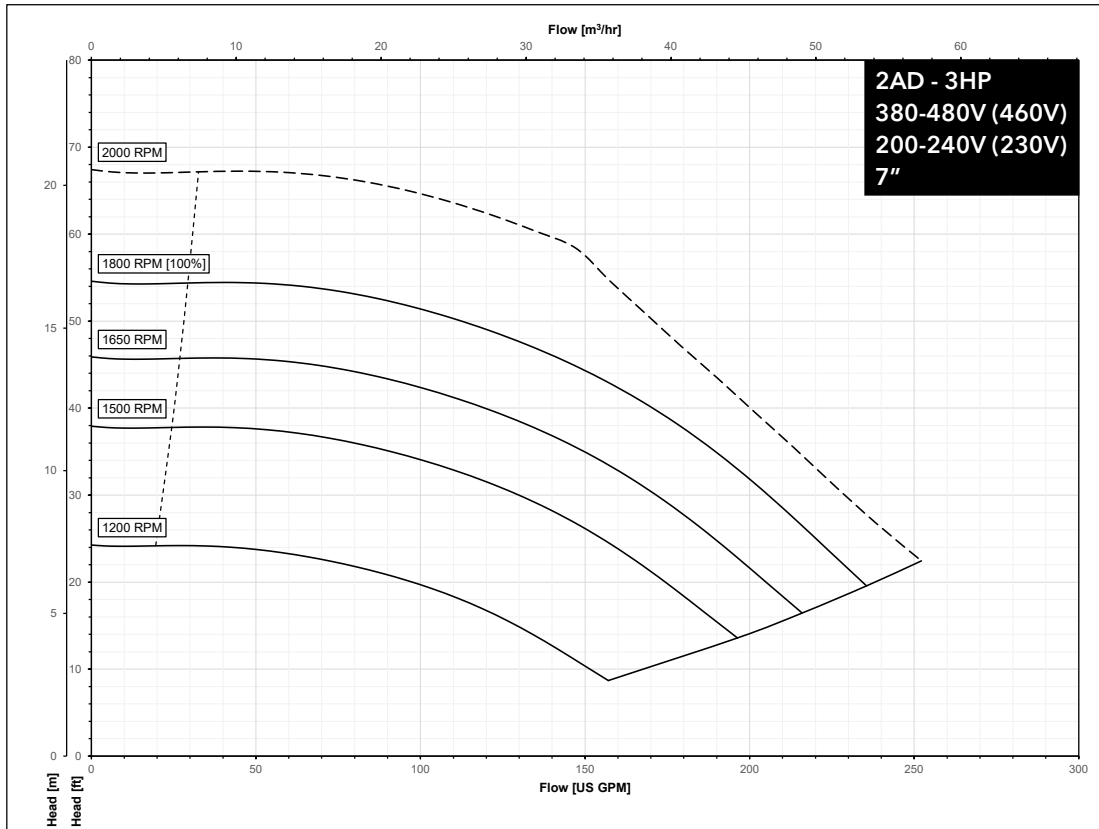

Series e-1531X & e-1532X PERFORMANCE CURVES FOR LOW SPEED MODELS

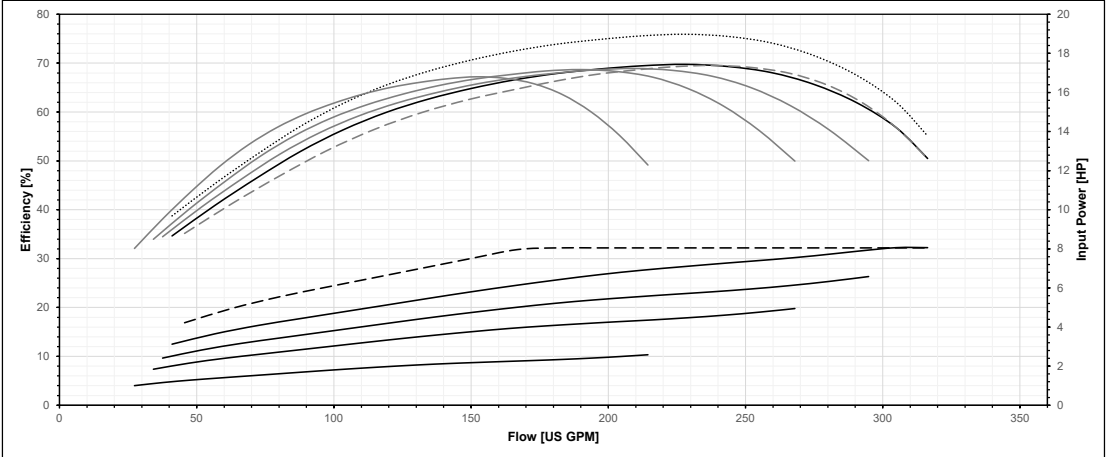
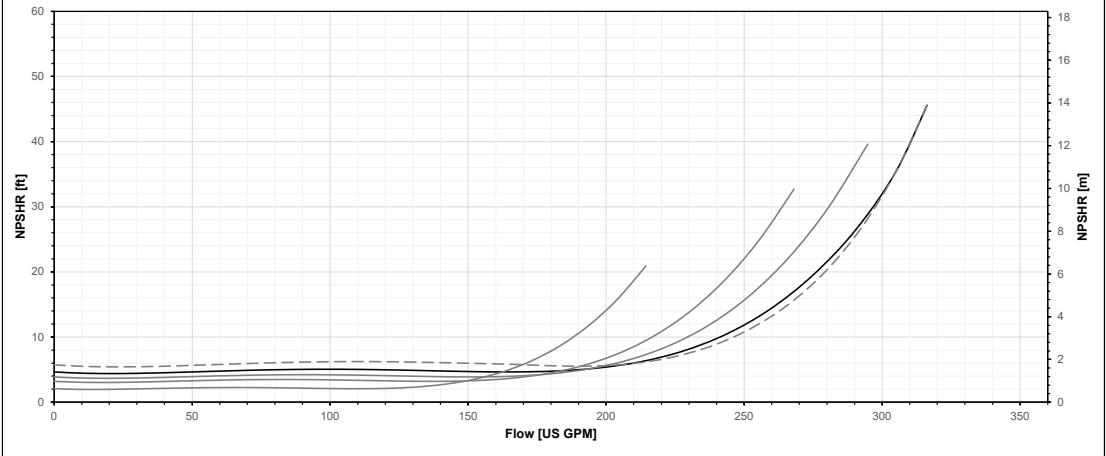
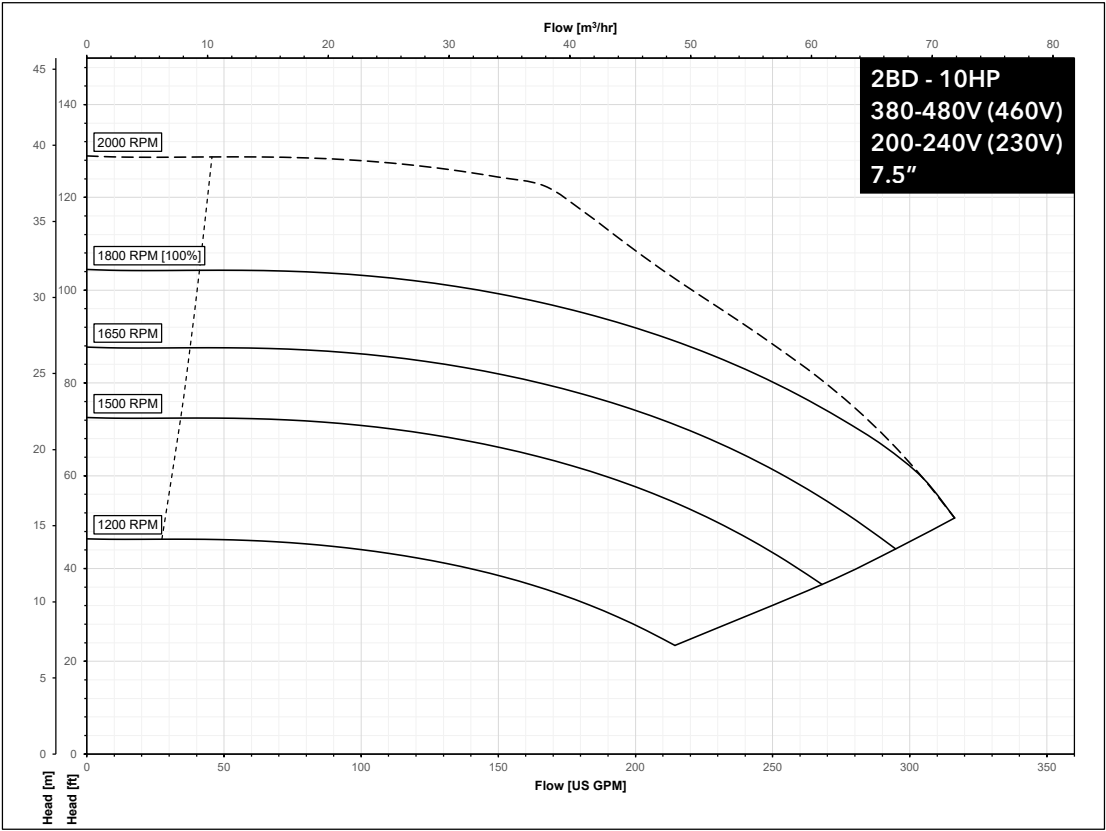

### Series e-1531X & e-1532X PERFORMANCE CURVES FOR LOW SPEED MODELS

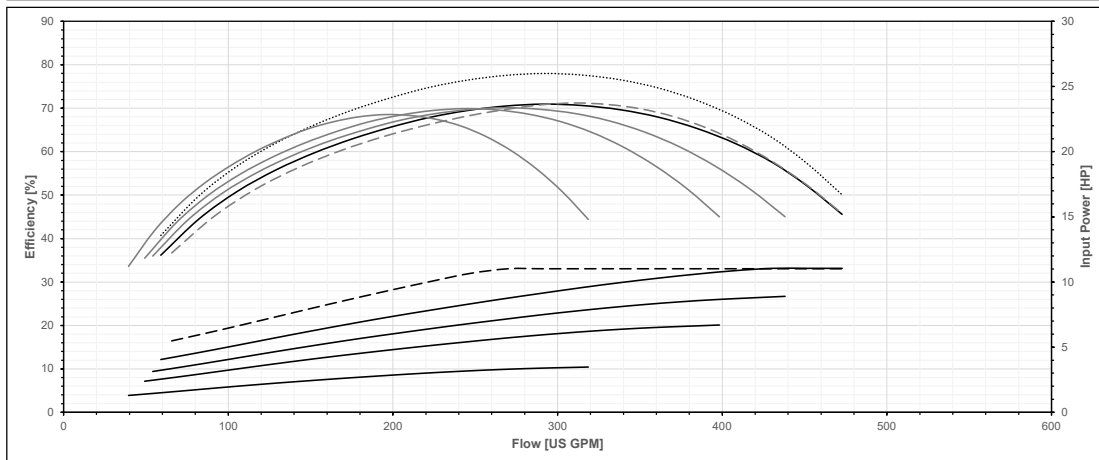
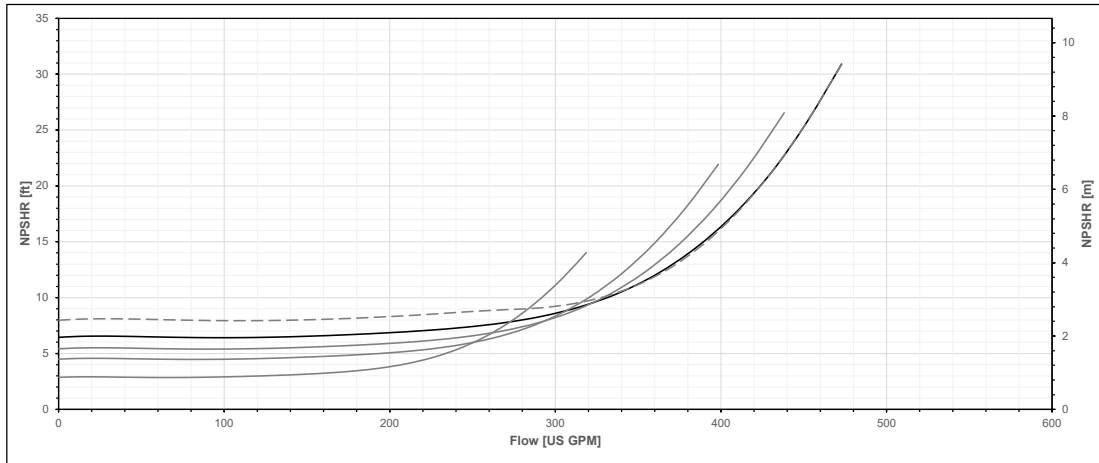
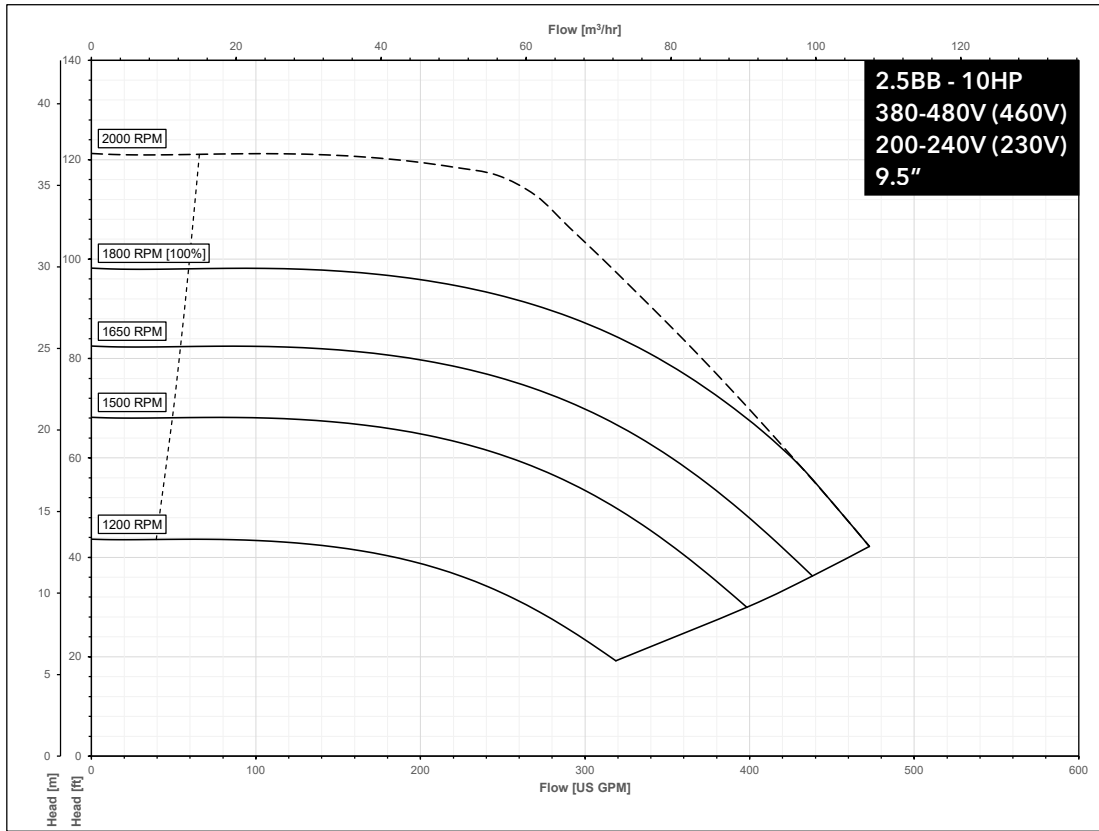

Series e-1531X & e-1532X PERFORMANCE CURVES FOR LOW SPEED MODELS

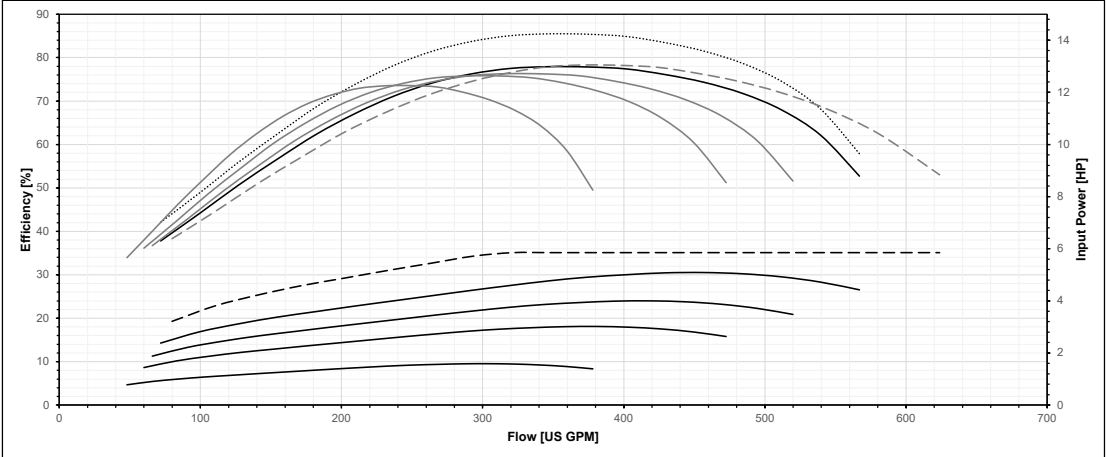
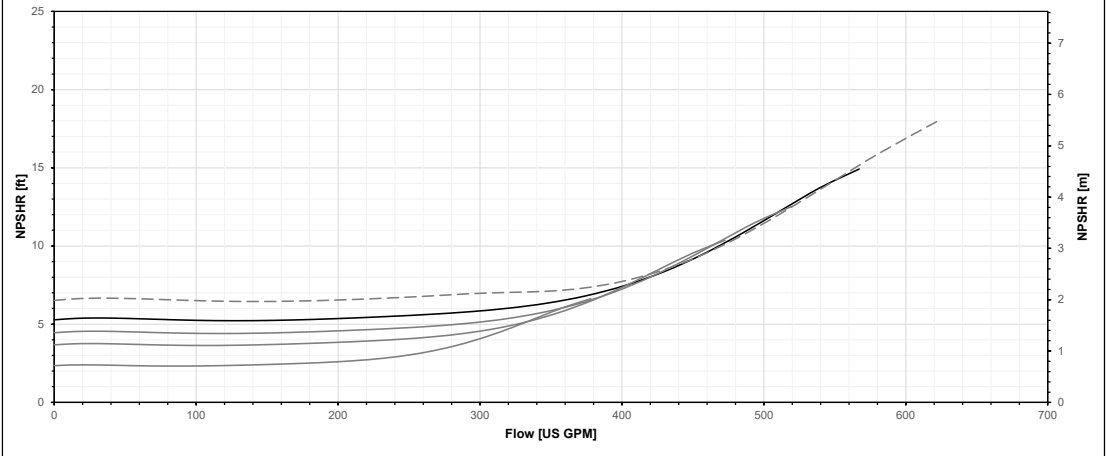
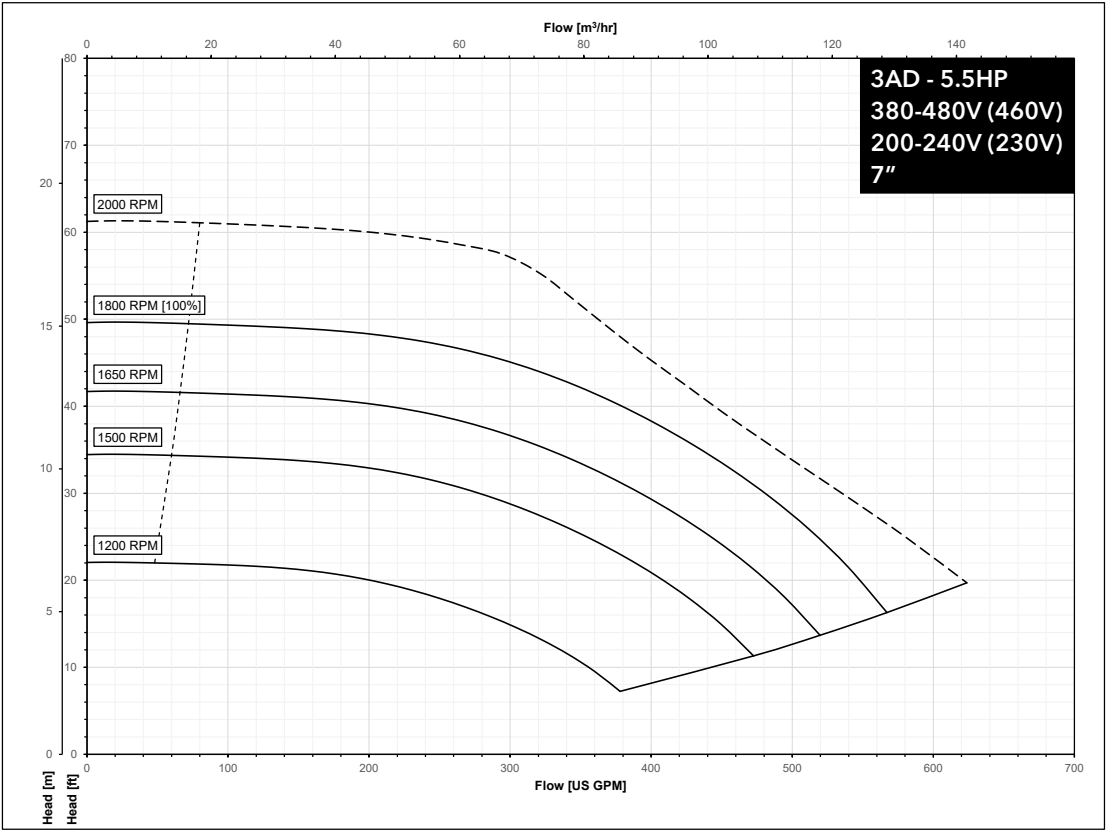

### Series e-1531X & e-1532X PERFORMANCE CURVES FOR LOW SPEED MODELS

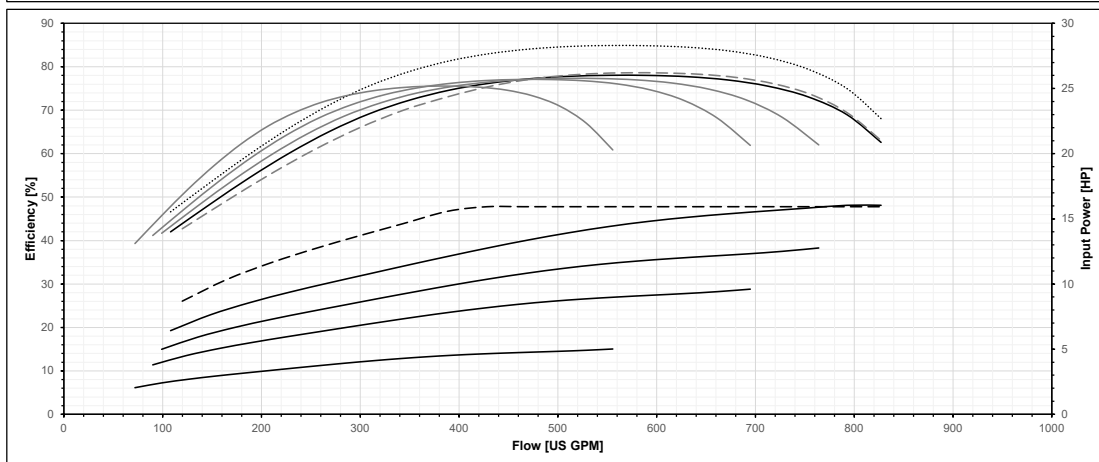
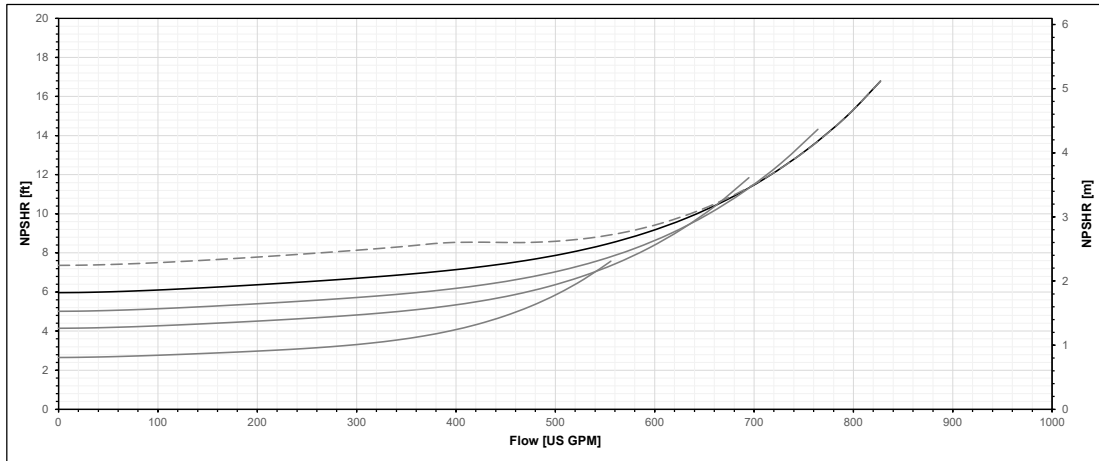
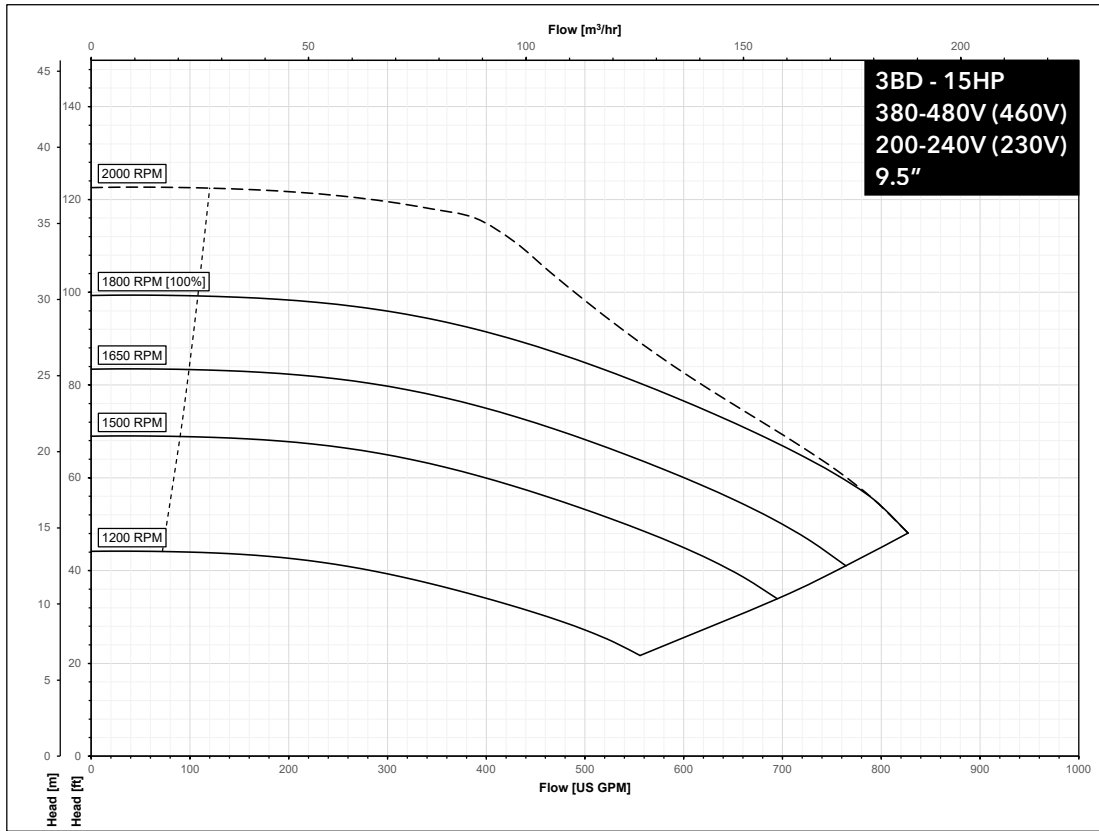

Series e-1531X & e-1532X PERFORMANCE CURVES FOR LOW SPEED MODELS

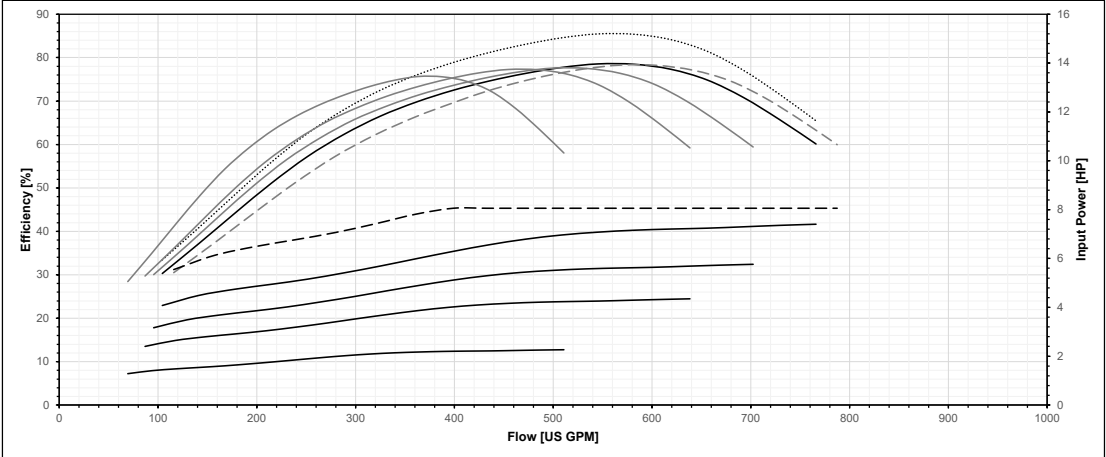
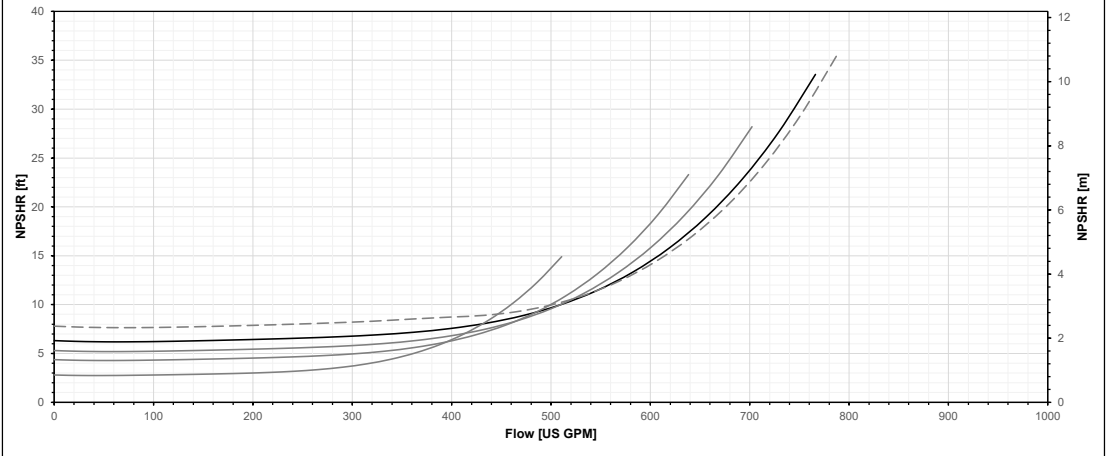
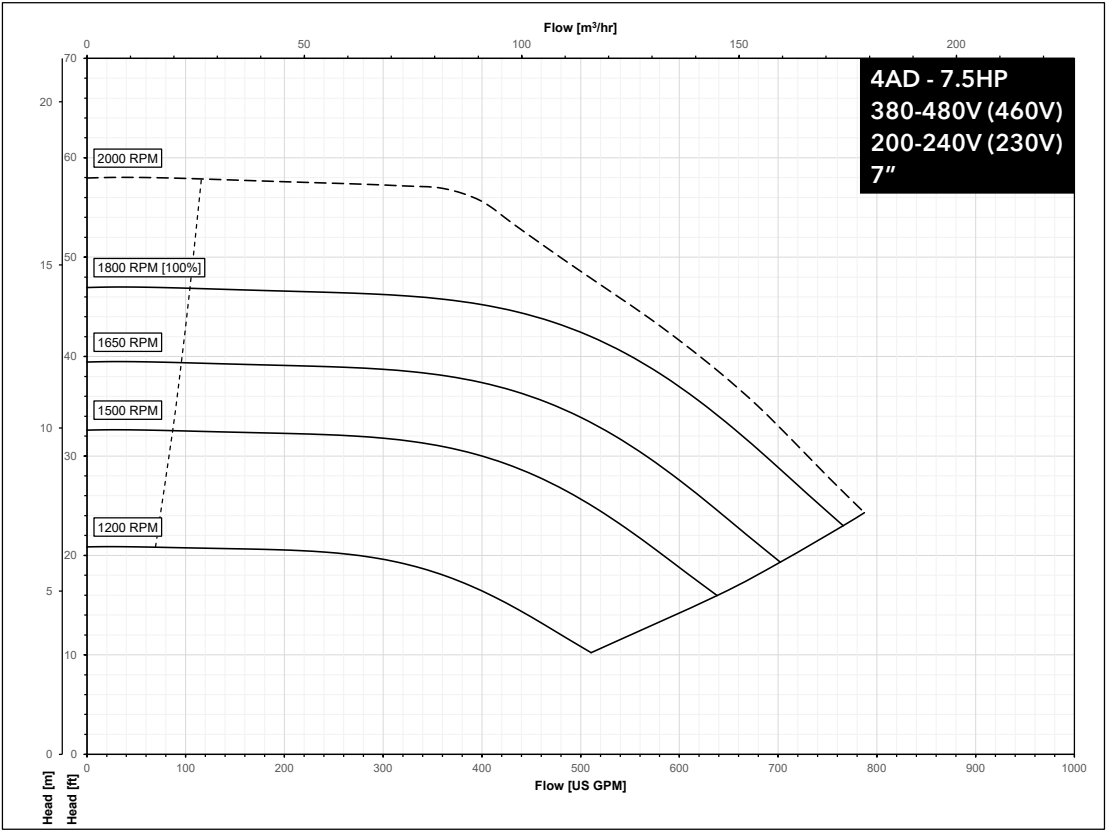

### Series e-1531X & e-1532X PERFORMANCE CURVES FOR LOW SPEED MODELS

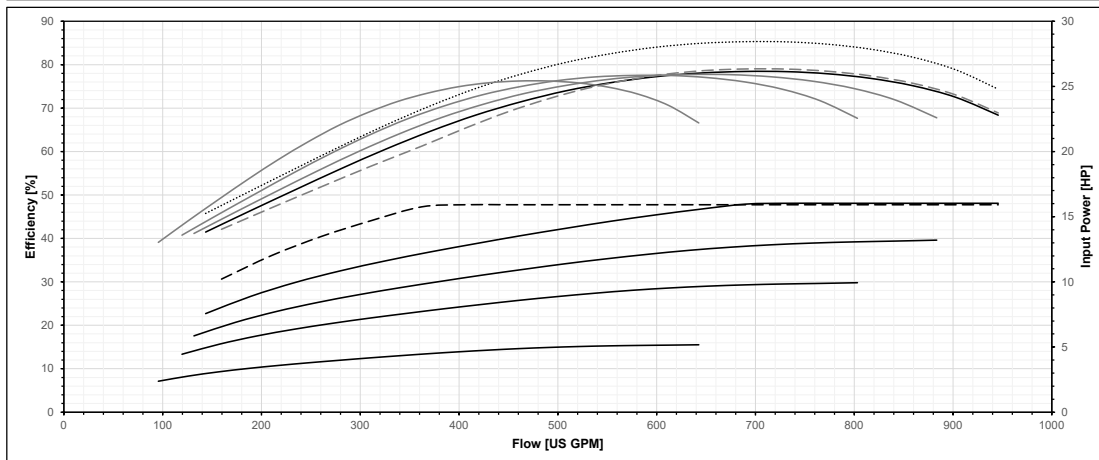
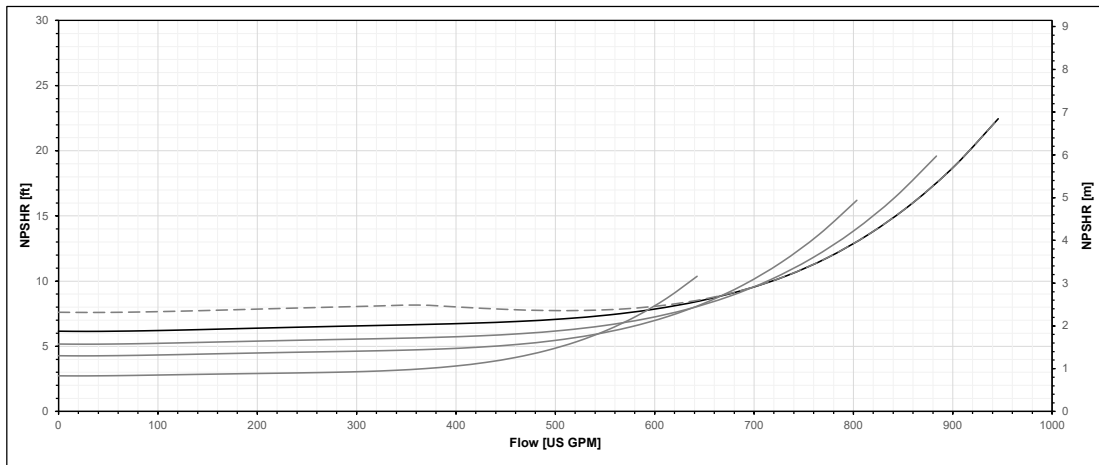
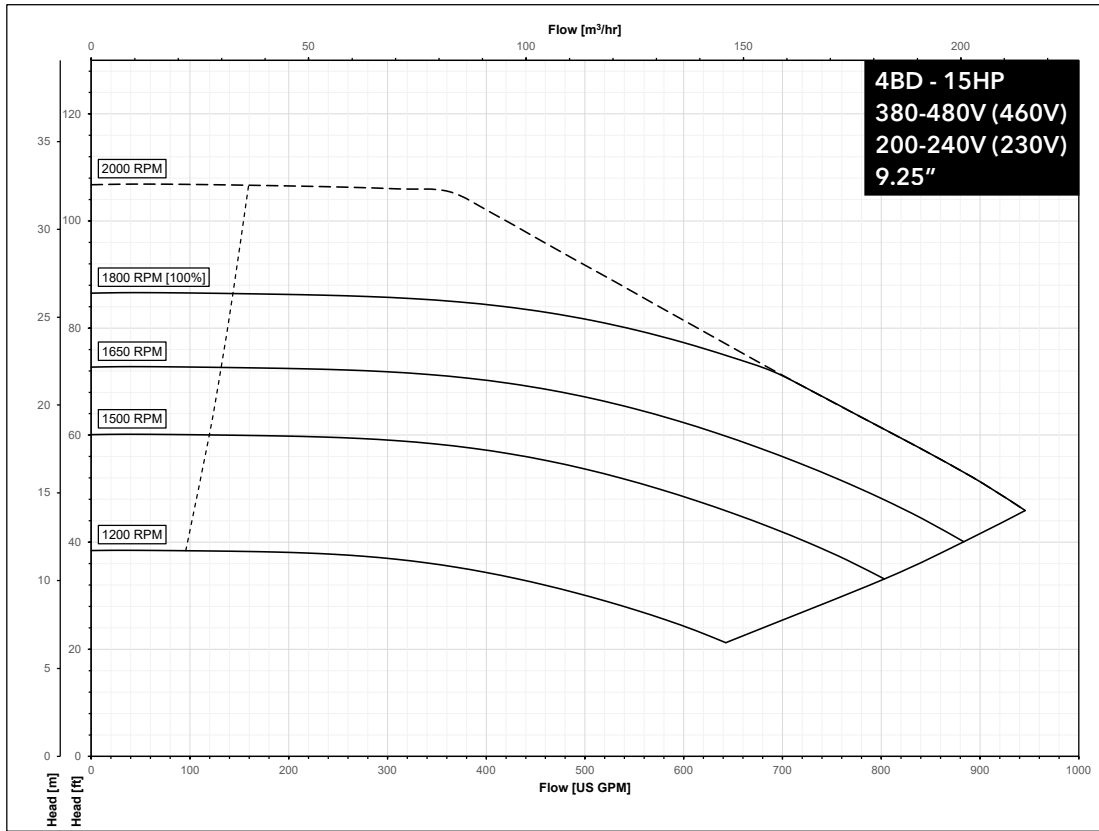

Series e-1531X & e-1532X PERFORMANCE CURVES FOR LOW SPEED MODELS

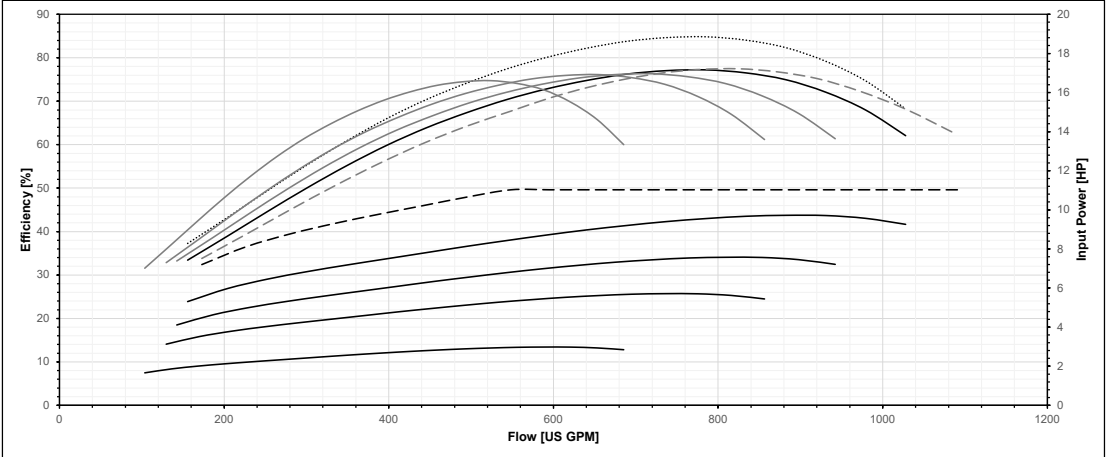
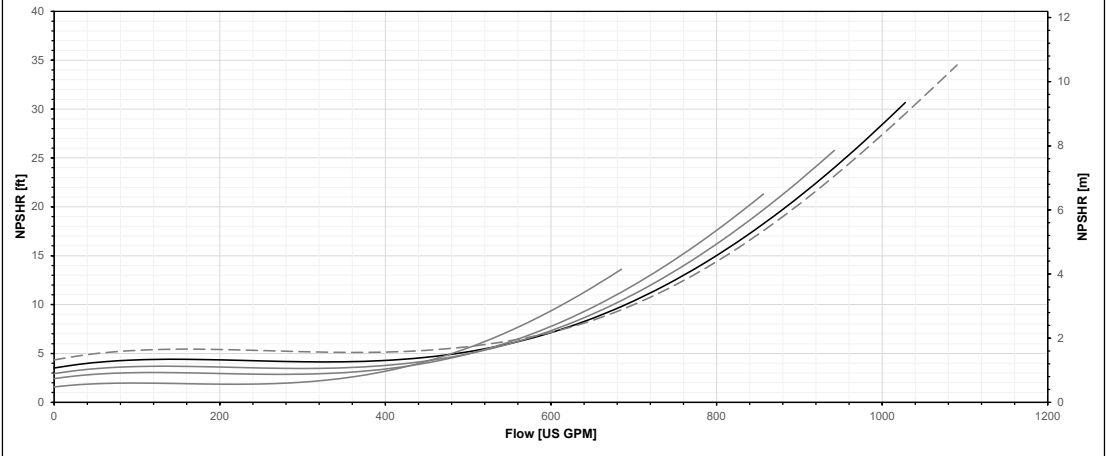
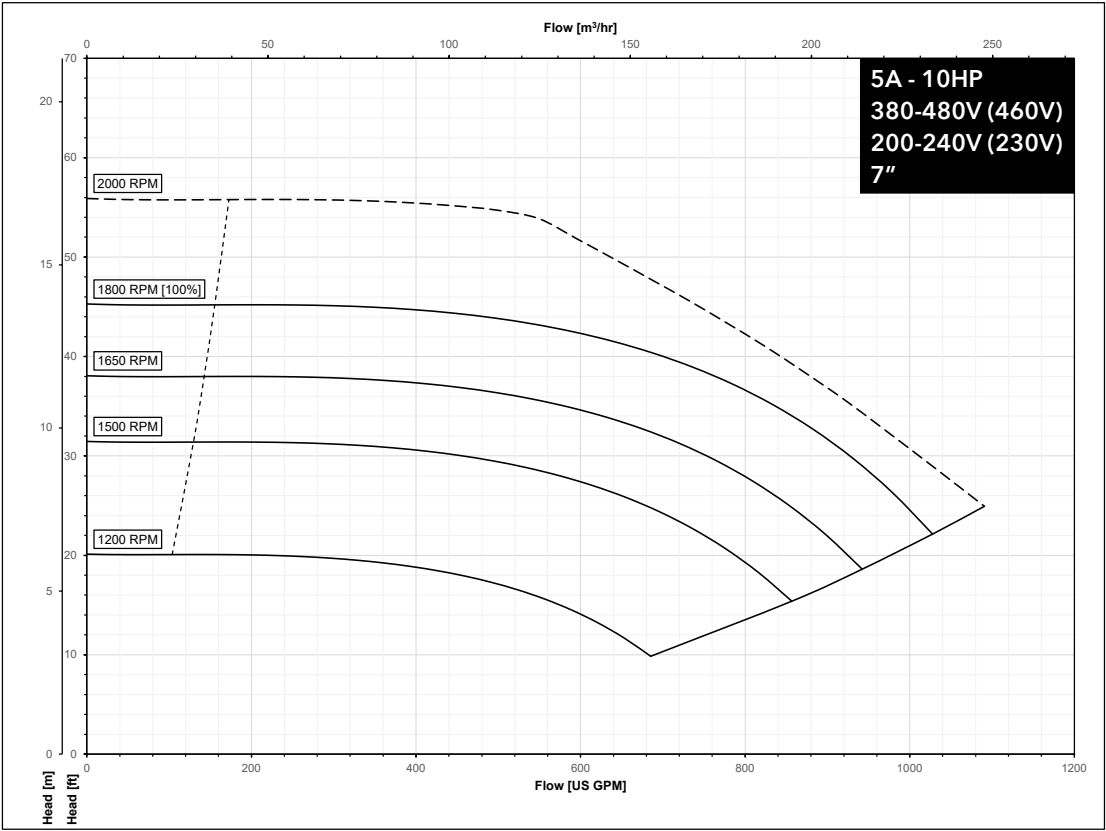



### Series e-1531X & e-1532X PERFORMANCE CURVES FOR LOW SPEED MODELS

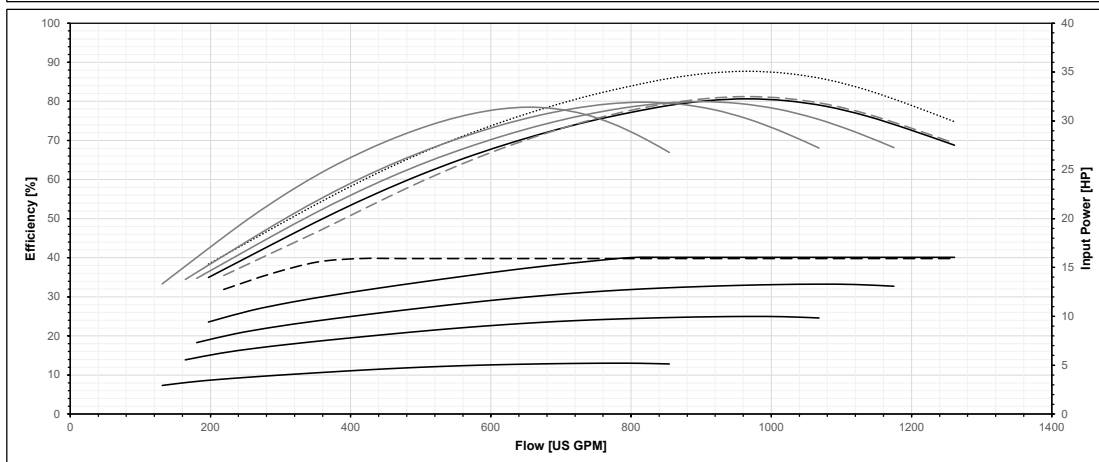
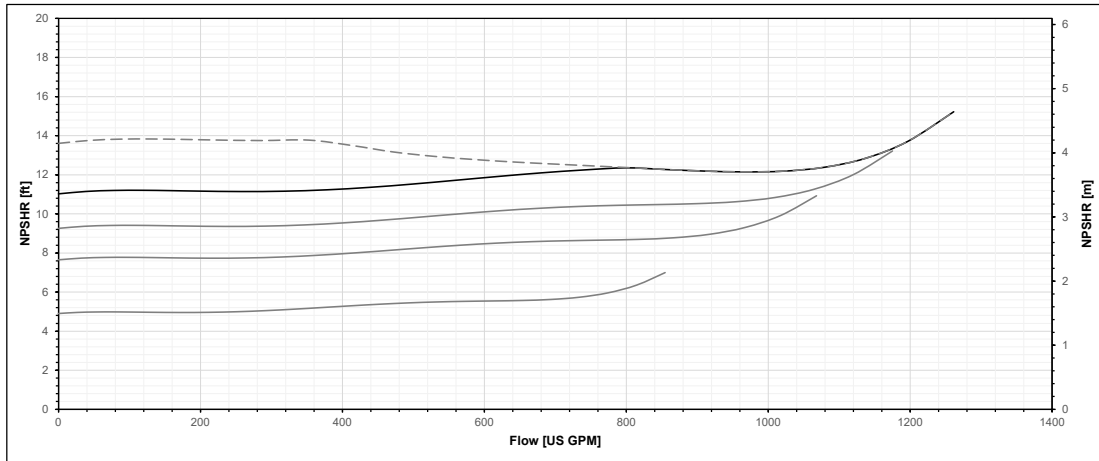
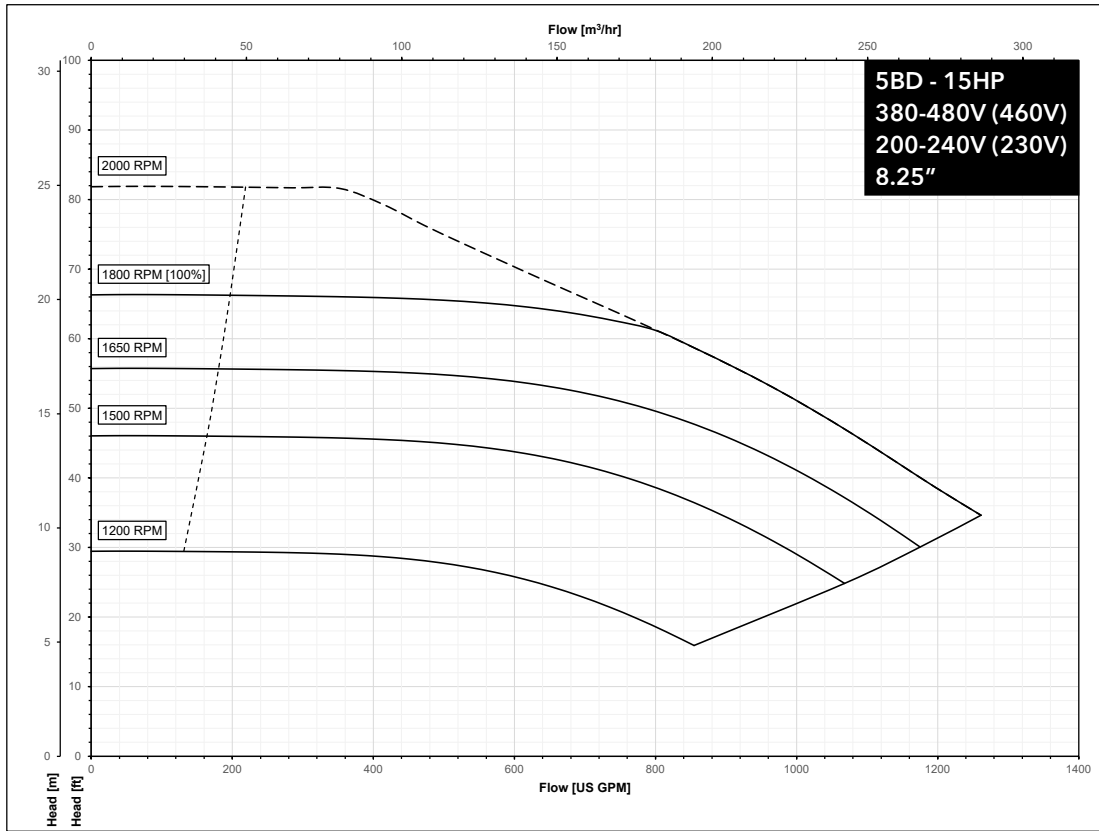

Series e-1531X & e-1532X PERFORMANCE CURVES FOR LOW SPEED MODELS

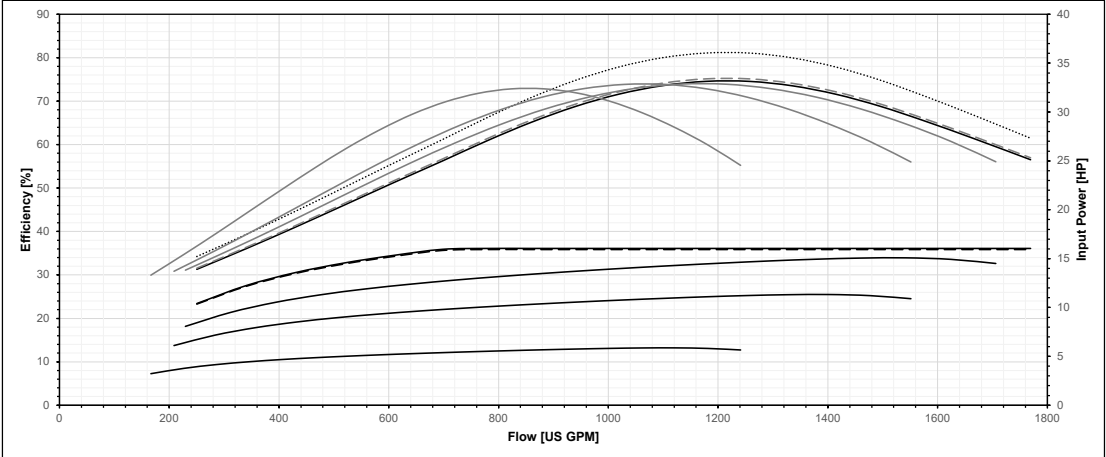
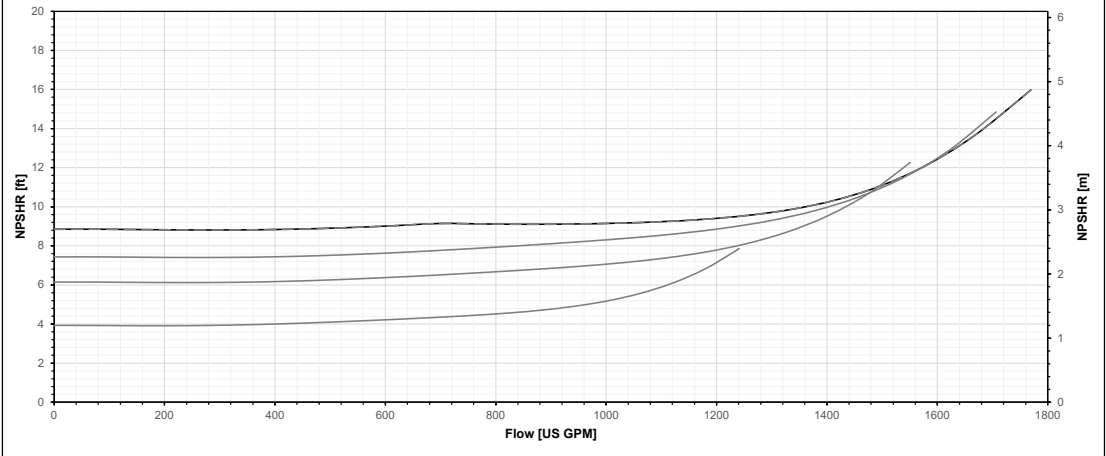
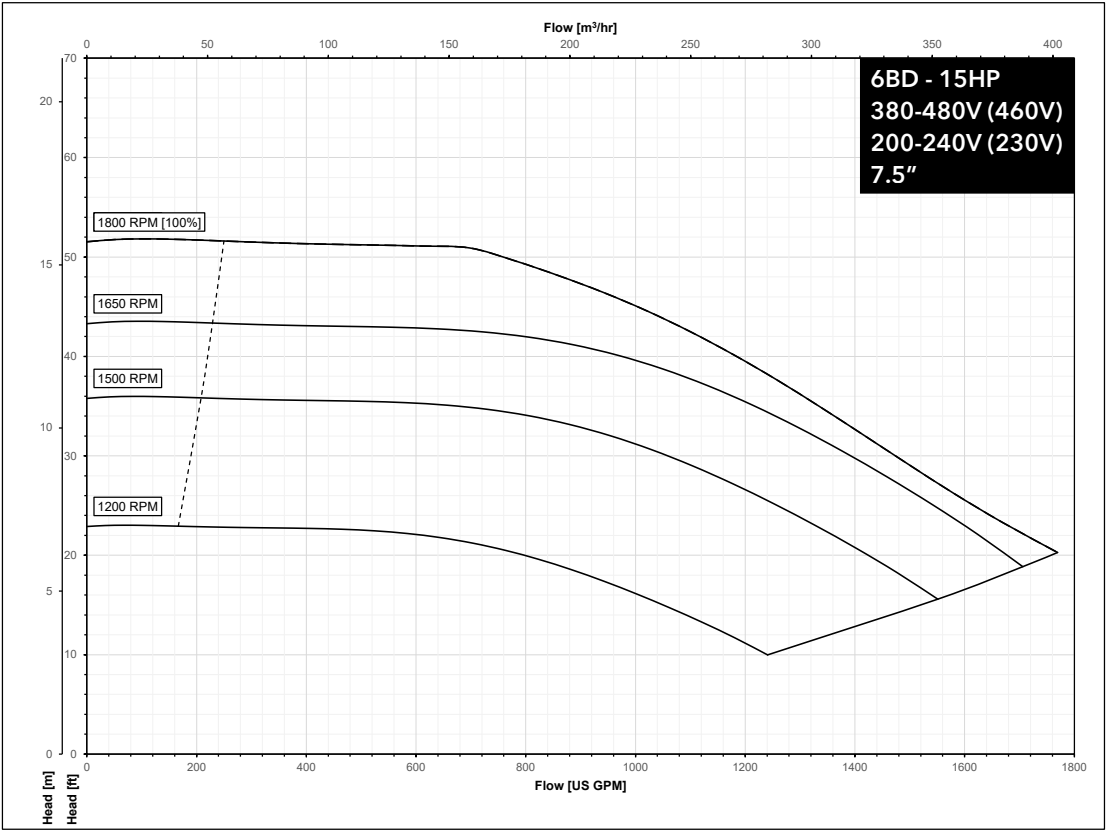

### Series e-1531X & e-1532X PERFORMANCE CURVES FOR LOW SPEED MODELS

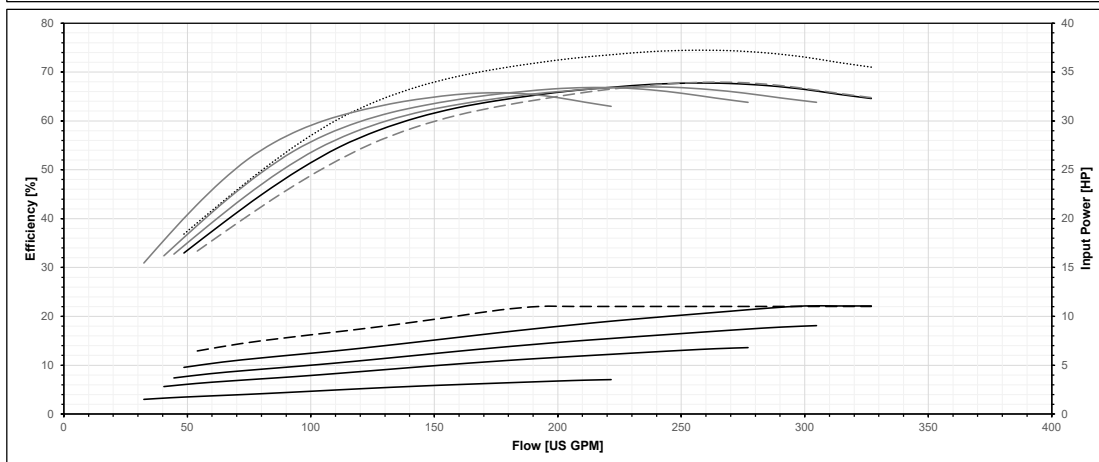
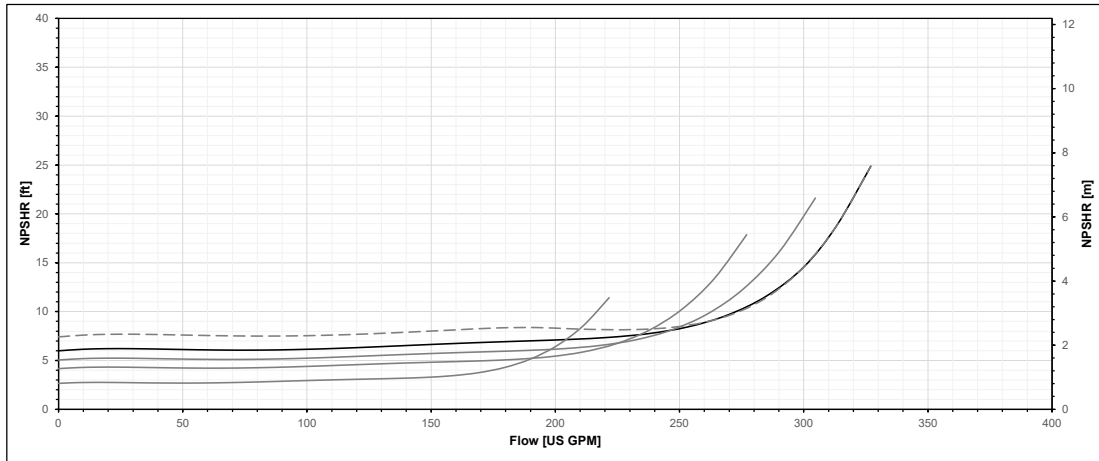
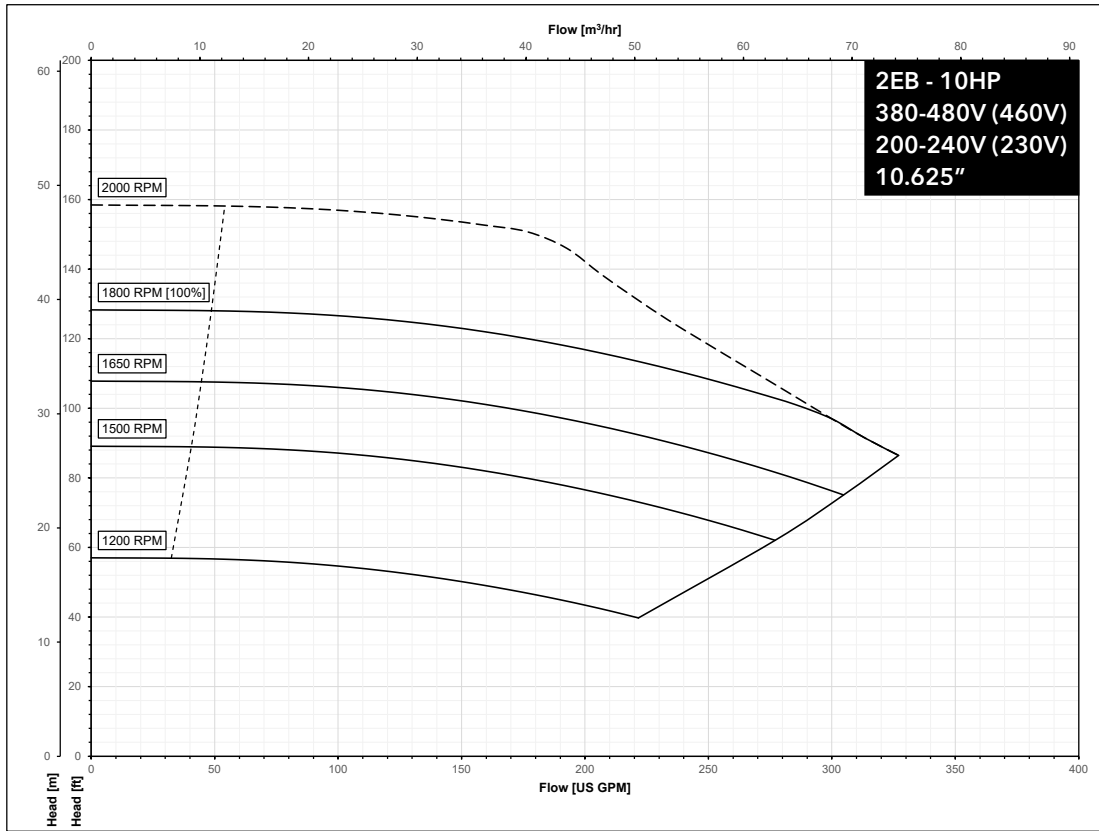

Series e-1531X & e-1532X PERFORMANCE CURVES FOR LOW SPEED MODELS

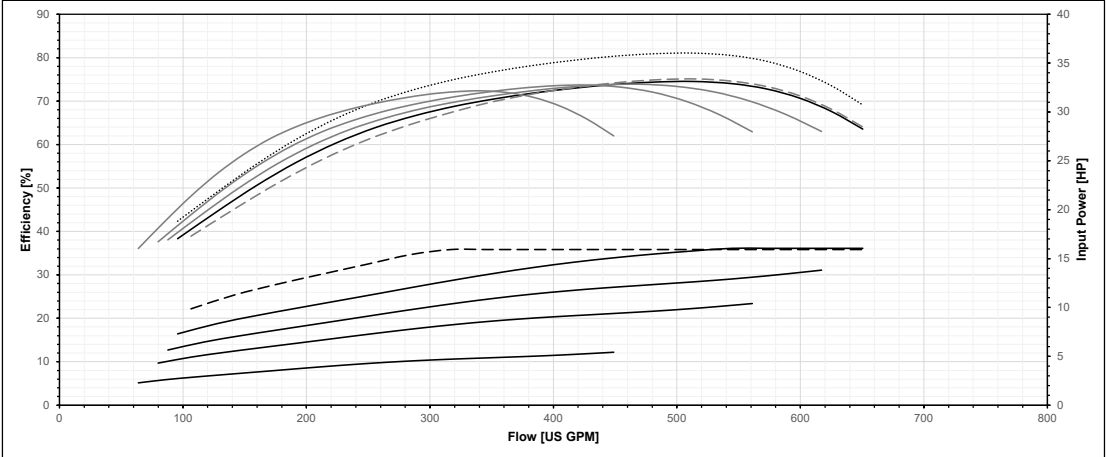
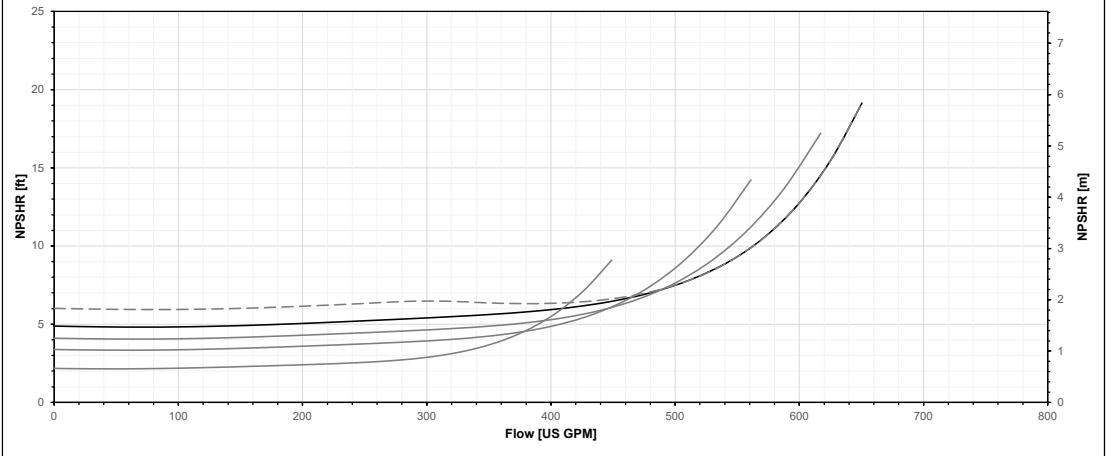
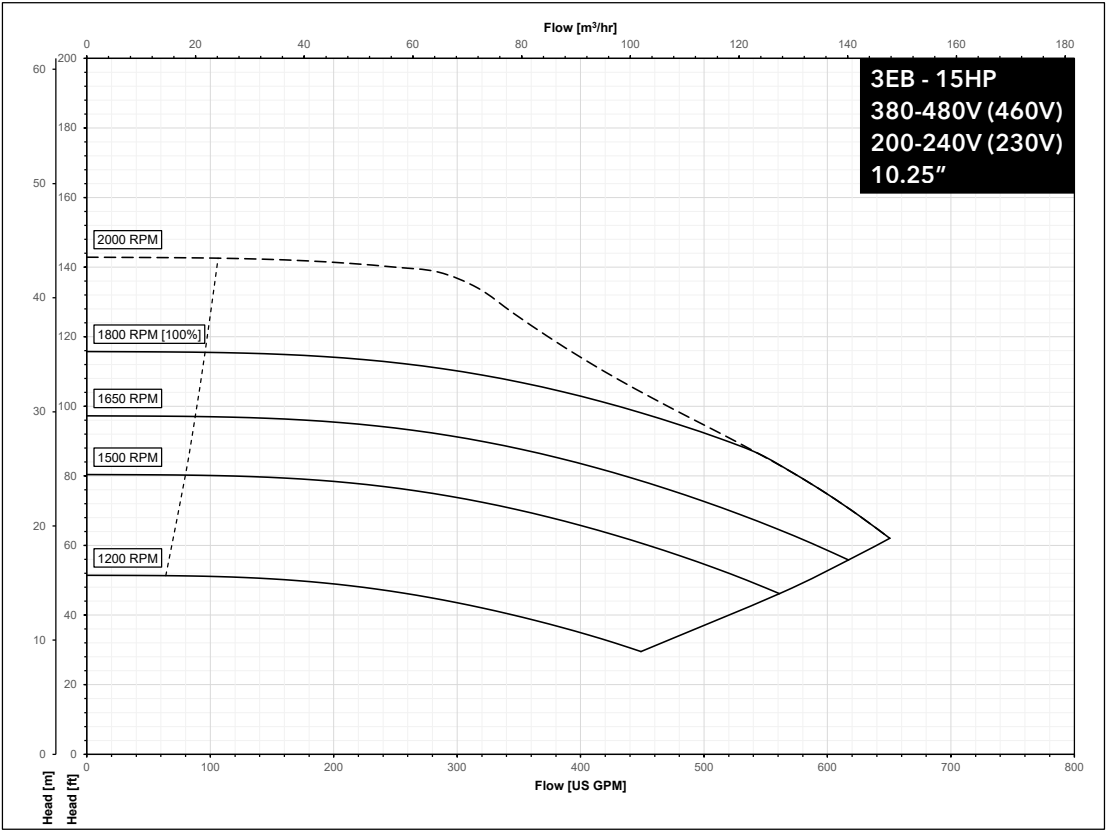

### Series e-1531X & e-1532X PERFORMANCE CURVES FOR LOW SPEED MODELS

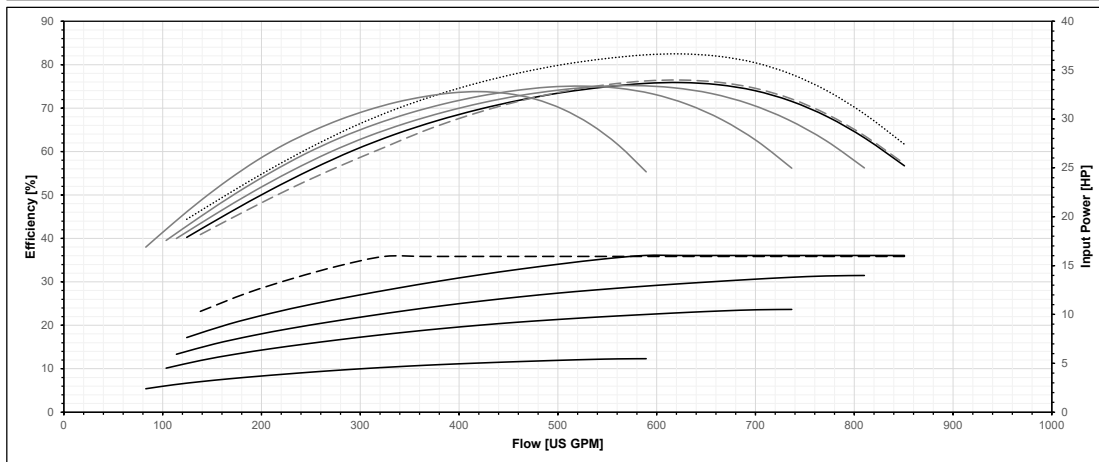
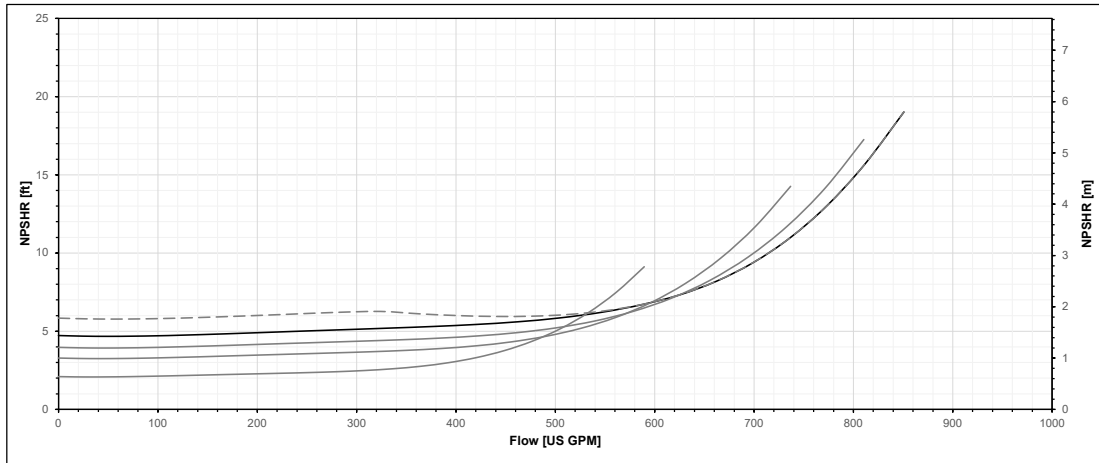
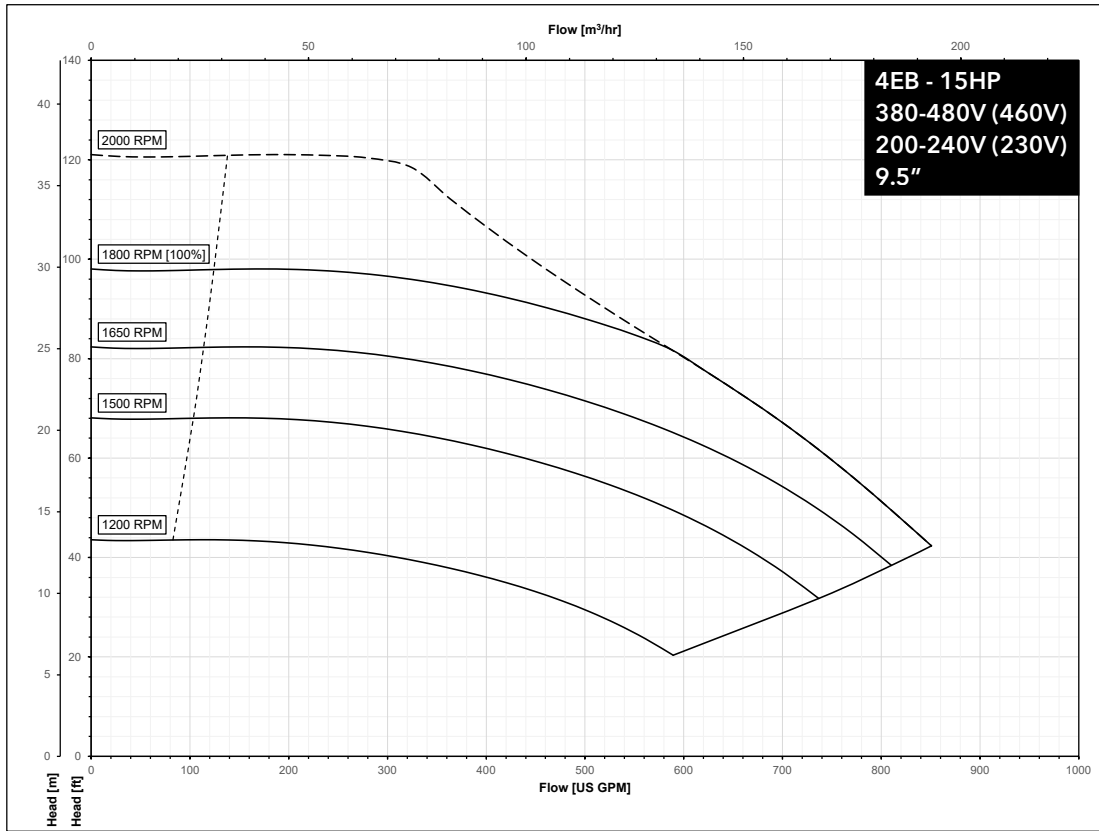

Series e-1531X & e-1532X PERFORMANCE CURVES FOR LOW SPEED MODELS

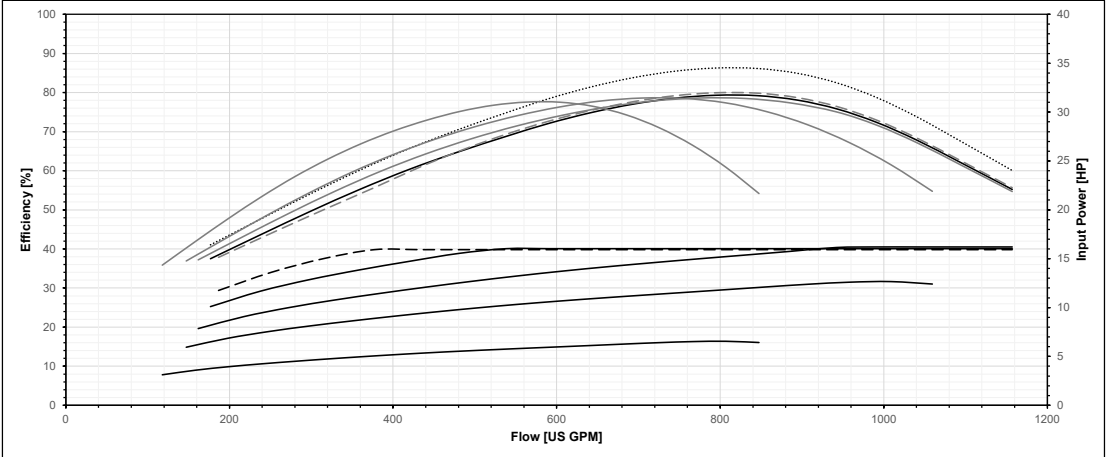
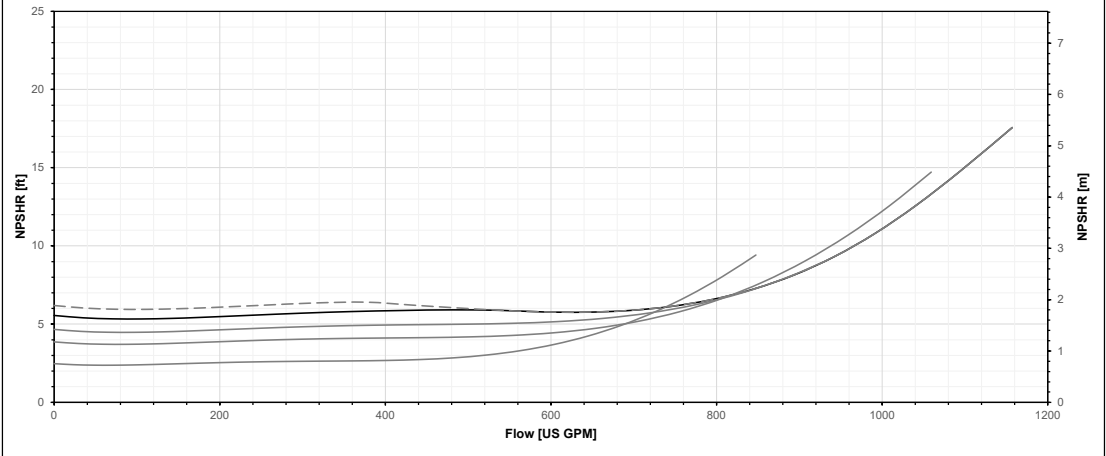
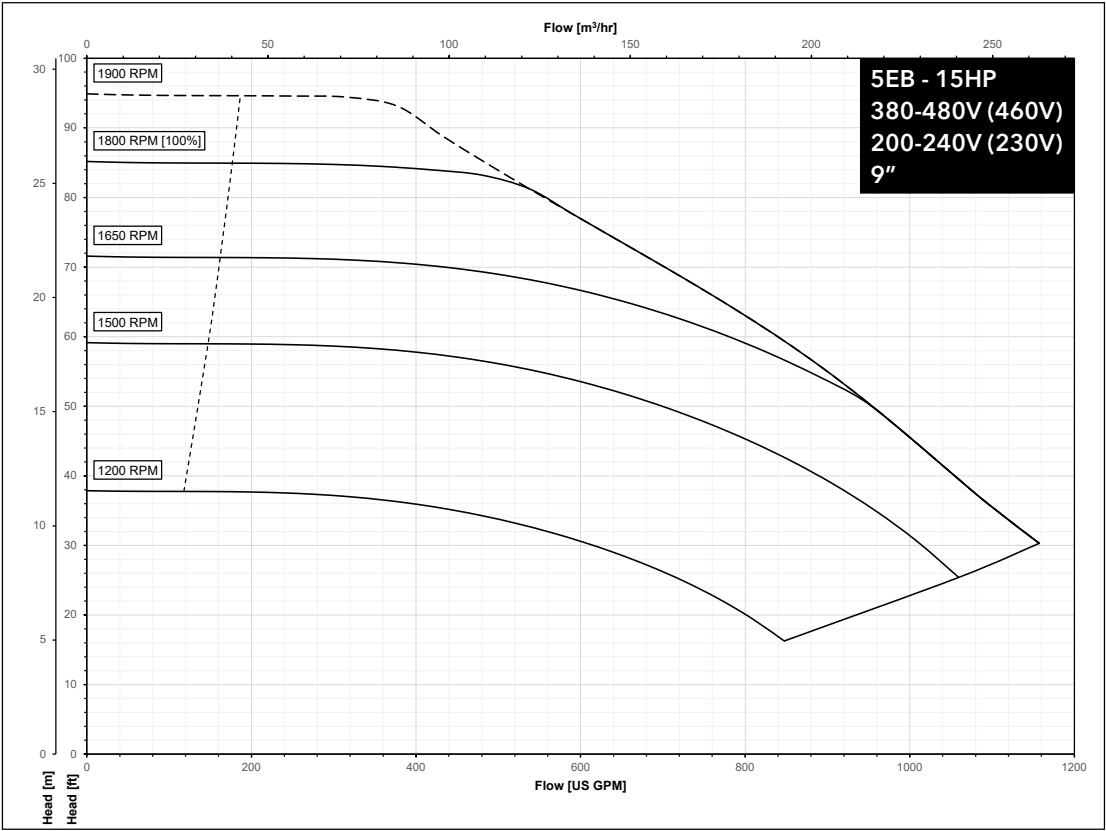

### Series e-1531X & e-1532X PERFORMANCE CURVES FOR LOW SPEED MODELS

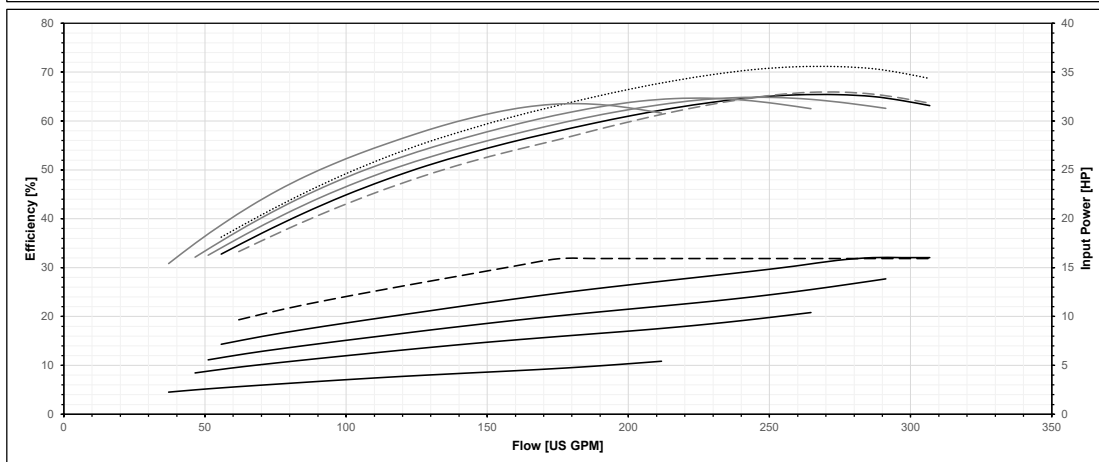
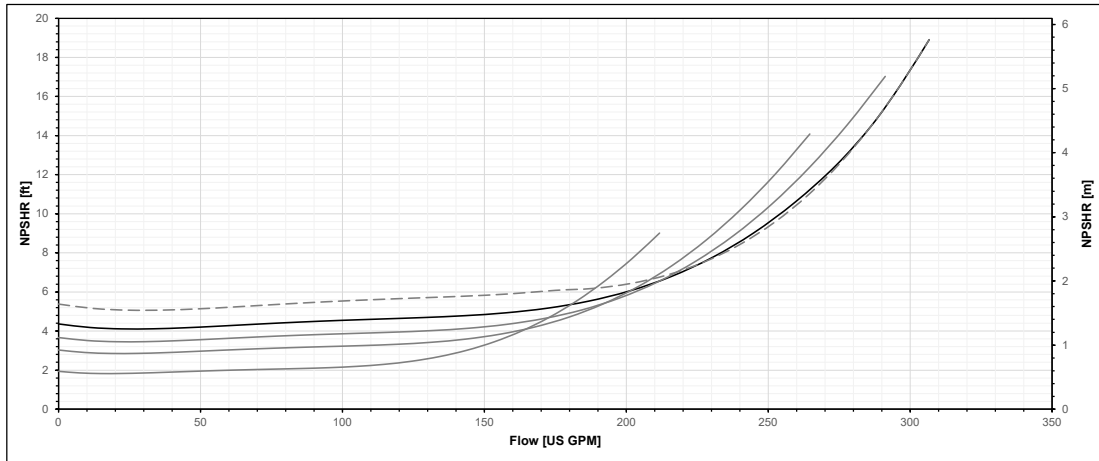
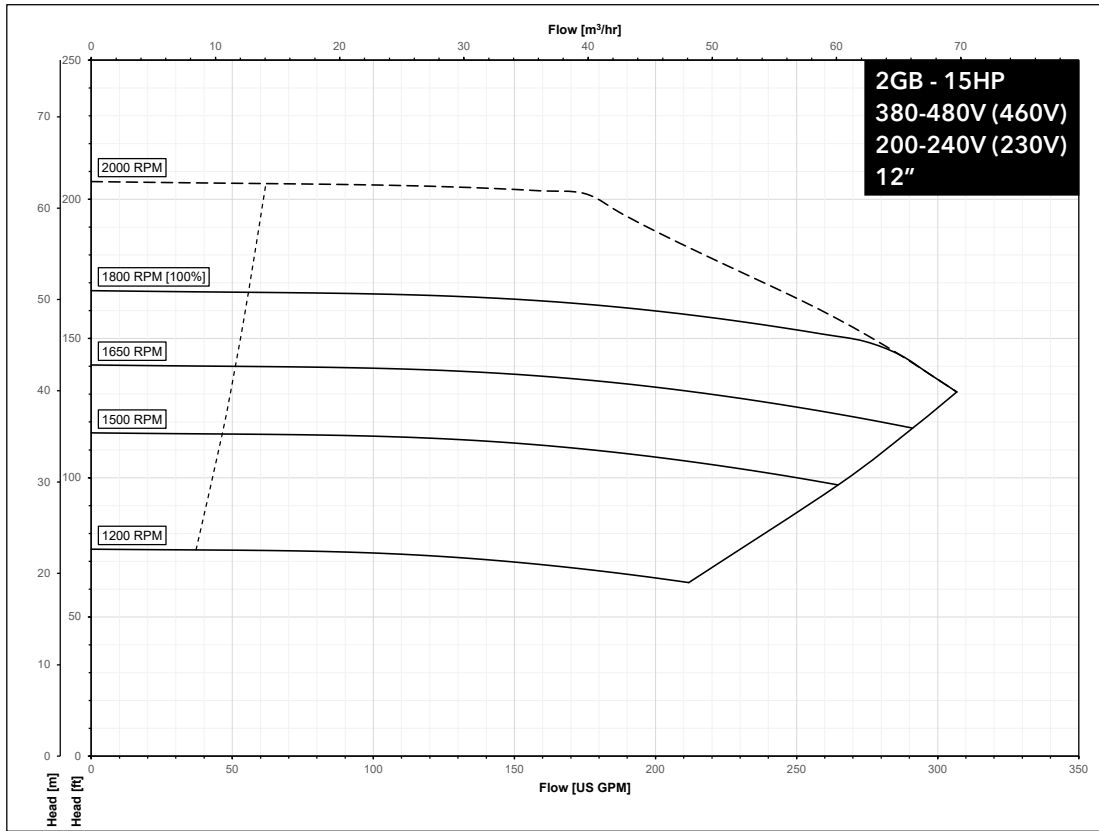

Series e-1531X & e-1532X PERFORMANCE CURVES FOR LOW SPEED MODELS

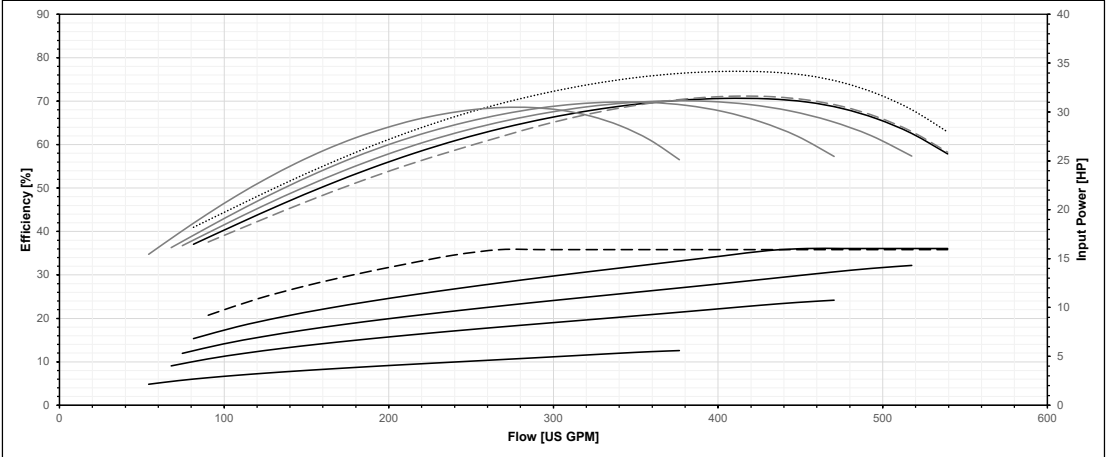
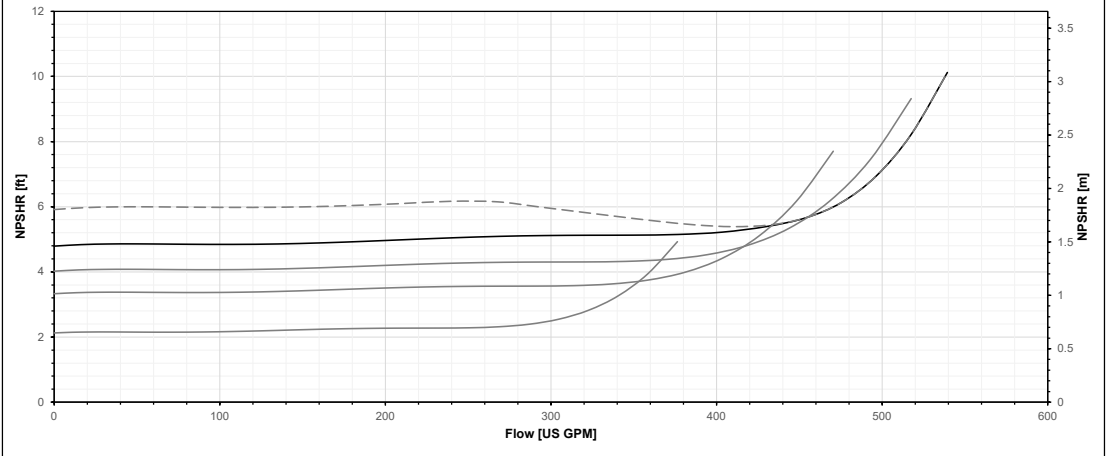
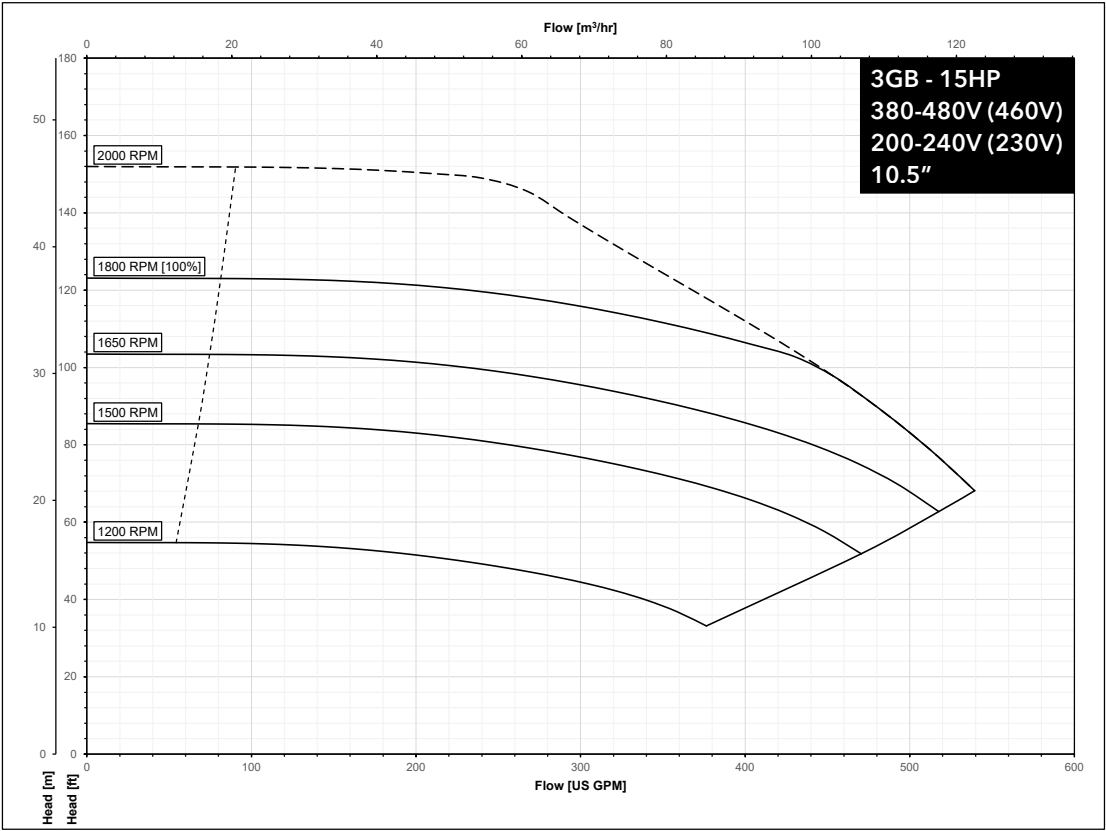



### Series e-1531X & e-1532X PERFORMANCE CURVES FOR LOW SPEED MODELS

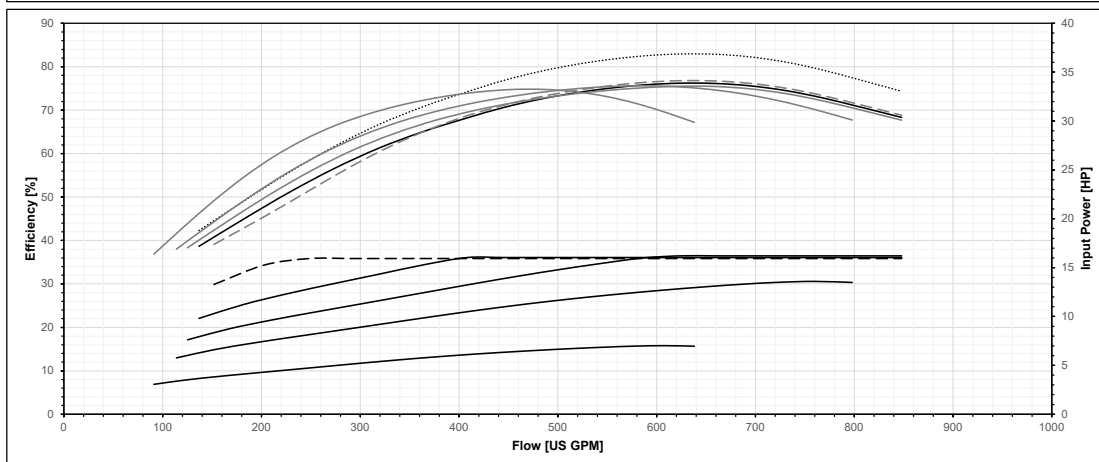
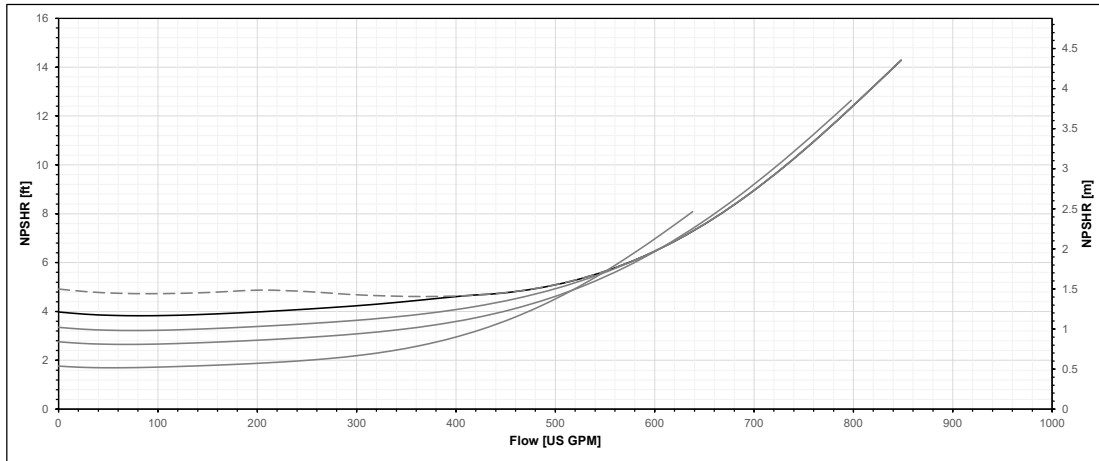
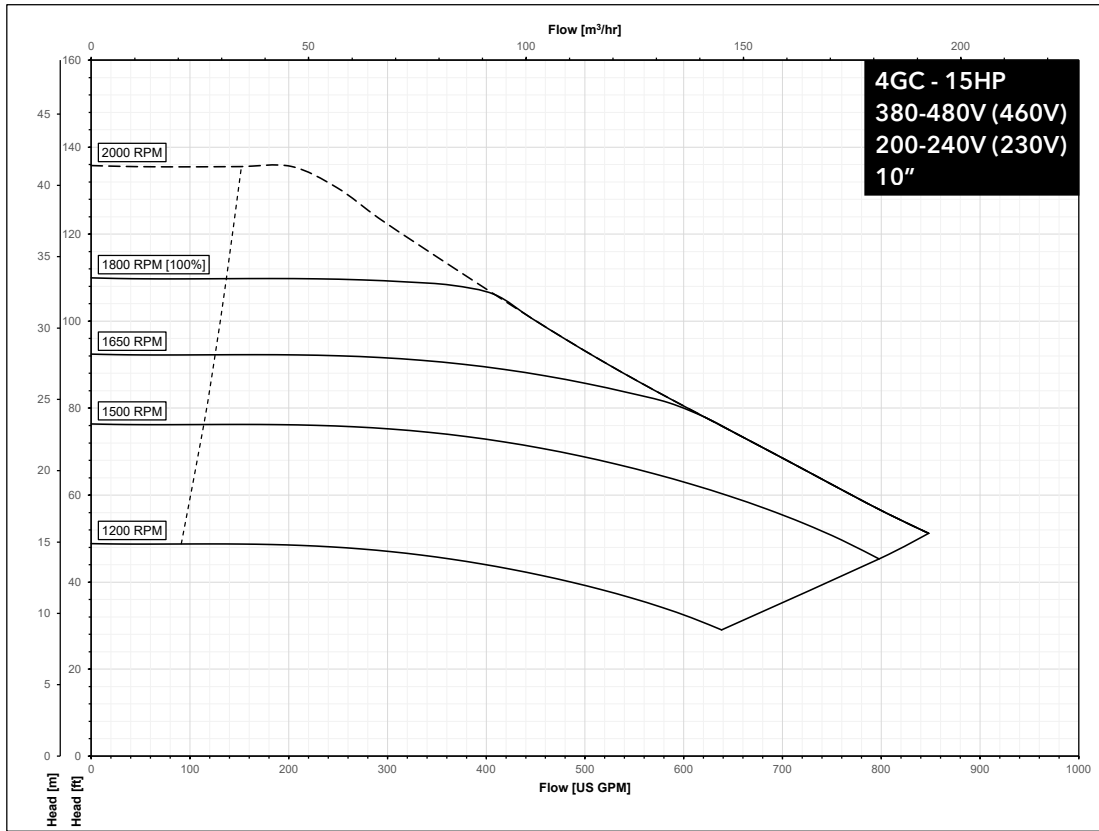

## MATERIALS OF CONSTRUCTION

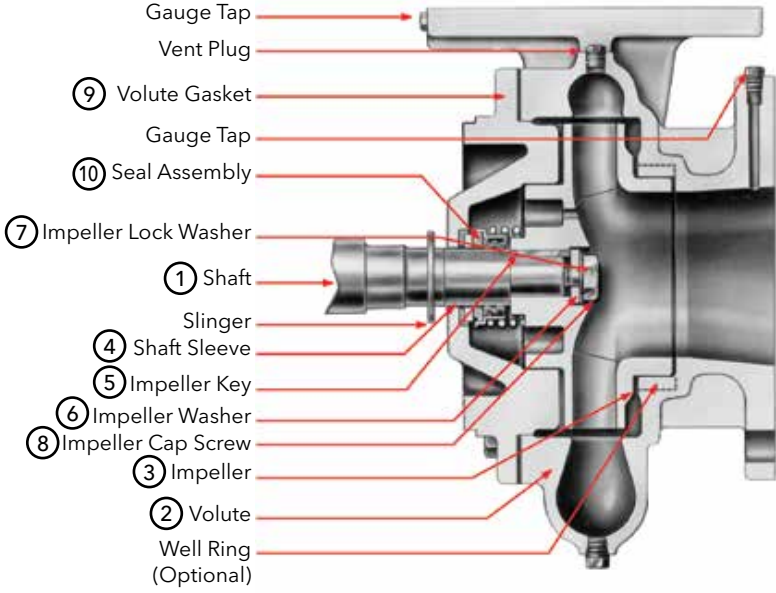

#	DESCRIPTION	MATERIAL
1	Shaft	Carbon Steel
2	Volute	Cast Iron ASTM A48 Class 30B
3	Impeller	ASTM A743 Grade CF8 - 304 Stainless Steel
4	Shaft Sleeve	ASTM 312 Grade TP304 - 304 Stainless Steel
5	Impeller Key	304 Stainless Steel
6	Impeller Washer	Steel
7	Impeller Lock Washer	304 Stainless Steel
8	Impeller Cap Screw	304 Stainless Steel
9	Volute Gasket	Cellulose Fiber
10	Seal Assembly	Reference Seal Data Tables

**Standard Configuration**

## SEAL ASSEMBLIES

### Mechanical Seal Options

OPTIONS	BUNA/Carbon/Ceramic	EPR/SiC/SiC
Temperature Range	-20° to 225°F (-29° to 107°C)	-20° to 250°F (-29° to 121°C)
Maximum Pressure	175 PSI	175 PSI
pH Limitations	7.0 - 9.0	7.0 - 12.5
Elastomer	Buna	EPR (Ethylene Propylene Rubber)
Rotating Face	Carbon	Silicon Carbide
Stationary Face	Ceramic	Silicon Carbide
Hardware	Stainless Steel / Brass	Stainless Steel
Max Glycol/Water	50% / 50%	60% / 40%

### e-1531X - DIMENSIONS AND WEIGHTS

(All dimensions in inches and weights in lbs. Do not use for construction purposes.)

#### 1-531X With NPT Connections

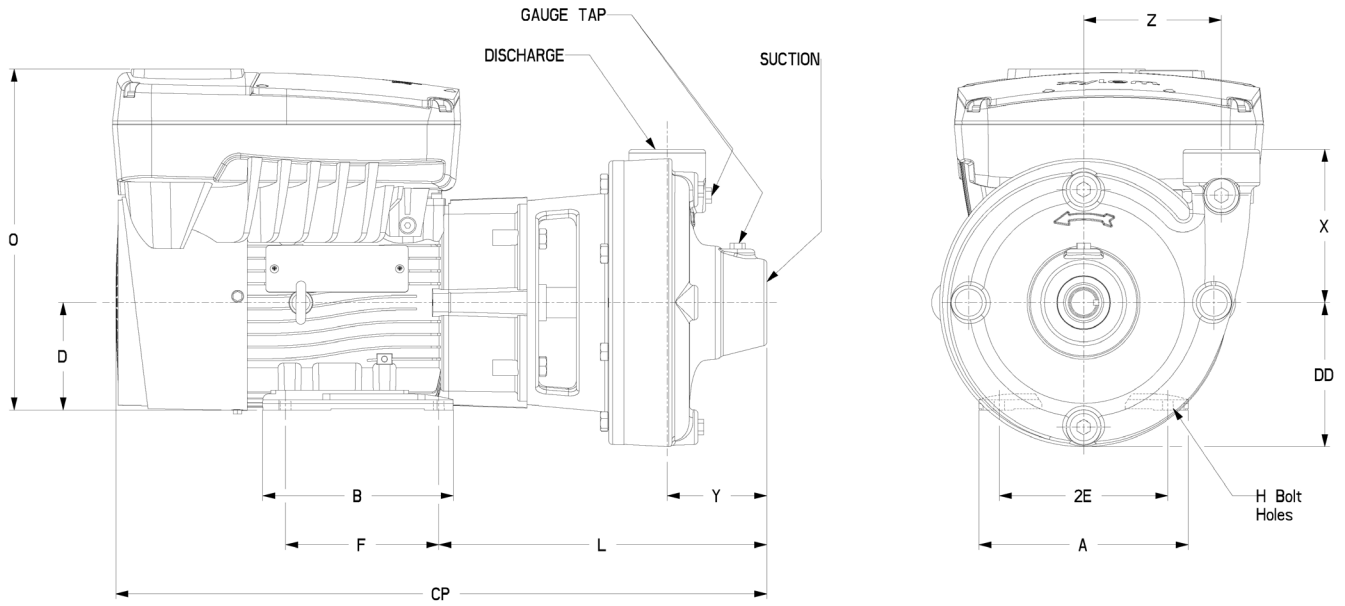

## Series e-1531X & e-1532X

### e-1531X - DIMENSIONS AND WEIGHTS

(All dimensions in inches and weights in lbs. Do not use for construction purposes.)

e-1531X with ANSI 125# flanged connections

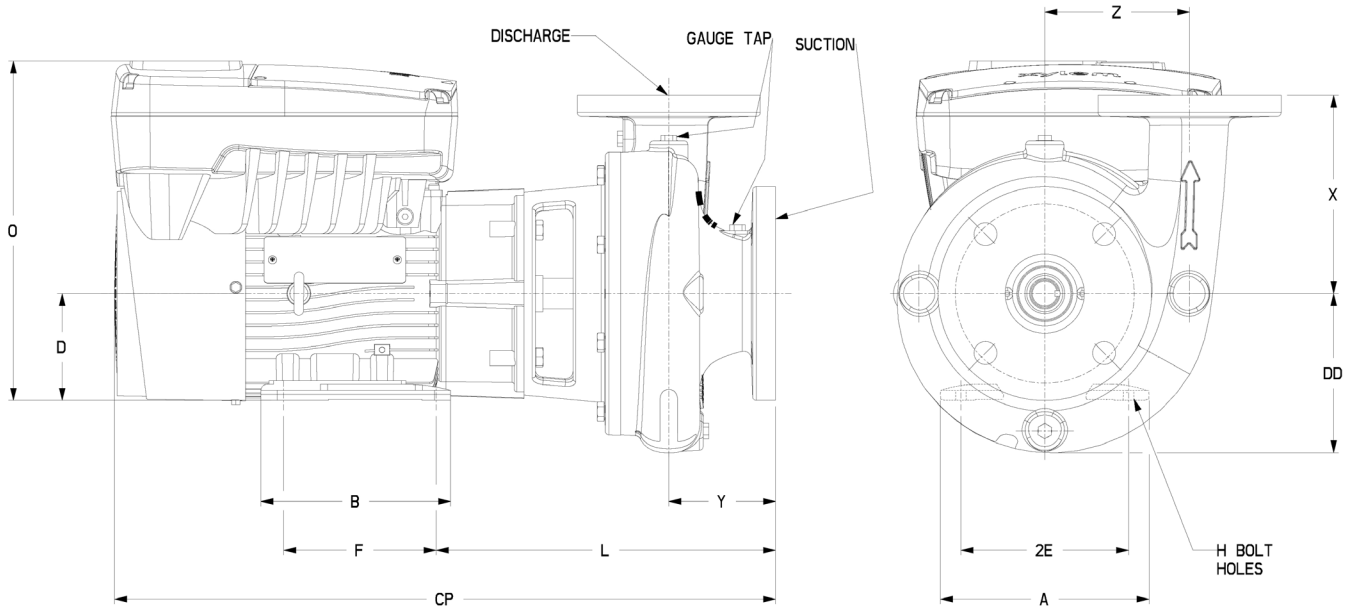

### High Speed (3000-4000 RPM) 3 Phase - 380-480V (460V Nominal Voltage)

Pump Size	e-1531X PN	Frame	NEMA Frame	A	B	CP	D	2E	F (Max)	H	L	O	DD	X	Y	Z	Weight (lbs)
1.25AD	1531XA1M4S..	S	213JM	10.04	8.42	24.015	5.25	8.5	7	0.41	12.375	14.73	4.75	5	3.25	4.5	162
1.25AD	1531XA1L4S..	S	143JM	6.84	6.34	21.295	3.5	5.5	5	0.34	10.75	11.12	4.75	5	3.25	4.5	105
1.5AD	1531XB1N4S..	L	254JM	12.5	12.4	28.042	6.25	10	10	0.53	13.75	18.42	5	6	3.125	4.625	252
1.5AD	1531XB1R4S..	S	213JM	10.04	8.42	23.89	5.25	8.5	7	0.41	12.25	14.73	5	6	3.125	4.625	177
1.25BC	1531XA4Q4S..	L	254JM	12.5	12.4	28.167	6.25	10	10	0.53	13.875	18.42	6.125	8	3.25	5.5	272
1.5BC	1531XB4Q4S..	L	254JM	12.5	12.4	28.042	6.25	10	10	0.53	13.75	18.42	6.25	6.5	3.125	5.75	269
2.5AC	1531XD2P4S..	L	254JM	12.5	12.4	29.352	6.25	10	10	0.53	15.06	18.42	5.813	6	4.5	4.688	272
2.5AC	1531XD2M4S..	S	213JM	10.04	8.42	25.2	5.25	8.5	7	0.41	13.56	14.73	5.813	6	4.5	4.688	197
2AD	1531XC1P4S..	L	254JM	12.5	12.4	28.542	6.25	10	10	0.53	14.25	18.42	5.5	6.5	3.5	4.75	269
2AD	1531XC1R4S..	S	213JM	10.04	8.42	24.39	5.25	8.5	7	0.41	12.75	14.73	5.5	6.5	3.5	4.75	194
2BD	1531XC5Q4S..	L	254JM	12.5	12.4	29.042	6.25	10	10	0.53	14.75	18.42	6.875	7	4	5.875	277
2BD	1531XC5N4S..	L	254JM	12.5	12.4	29.042	6.25	10	10	0.53	14.75	18.42	6.875	7	4	5.875	277
3AD	1531XE1Q4S..	L	254JM	12.5	12.4	29.292	6.25	10	10	0.53	15	18.42	6.25	6	4.125	5	291
3AD	1531XE1P4S..	L	254JM	12.5	12.4	29.292	6.25	10	10	0.53	15	18.42	6.25	6	4.125	5	291
4AD	1531XF1Q4S..	L	254JM	12.5	12.4	30.732	6.25	10	10	0.53	16.44	18.42	6.875	7.5	4.928	5.75	347

## Series e-1531X & e-1532X

### e-1531X - DIMENSIONS AND WEIGHTS

(All dimensions in inches and weights in lbs. Do not use for construction purposes.)

#### High Speed (3000-4000 RPM) 3 Phase - 200-240V (230V Nominal Voltage)

Pump Size	e-1531X PN	Frame	NEMA Frame	A	B	CP	D	2E	F (Max)	H	L	O	DD	X	Y	Z	Weight (lbs)
1.25AD	1531XA1L4R..	S	213JM	10.04	8.42	22.39	5.25	8.5	7	0.41	10.75	14.73	4.75	5	3.25	4.5	162
1.5AD	1531XB1N4R..	L	254JM	12.5	12.4	28.042	6.25	10	10	0.53	13.75	18.42	5	6	3.125	4.625	252
1.25BC	1531XA4N4R..	L	254JM	12.5	12.4	28.167	6.25	10	10	0.53	13.875	18.42	6.125	8	3.25	5.5	272
1.5BC	1531XB4N4R..	L	254JM	12.5	12.4	28.042	6.25	10	10	0.53	13.75	18.42	6.25	6.5	3.125	5.75	269
2.5AC	1531XD2N4R..	L	254JM	12.5	12.4	29.352	6.25	10	10	0.53	15.06	18.42	5.813	6	4.5	4.688	272
2.5AC	1531XD2M4R..	L	254JM	12.5	12.4	29.352	6.25	10	10	0.53	15.06	18.42	5.813	6	4.5	4.688	272
2AD	1531XC1N4R..	L	254JM	12.5	12.4	28.542	6.25	10	10	0.53	14.25	18.42	5.5	6.5	3.5	4.75	269
2BD	1510XC5N4R..	L	254JM	12.5	12.4	29.042	6.25	10	10	0.53	14.75	18.42	6.875	7	4	5.875	277
3AD	1531XE1N4R..	L	254JM	12.5	12.4	29.292	6.25	10	10	0.53	15	18.42	6.25	6	4.125	5	291
4AD	1531XF1N4R..	L	254JM	12.5	12.4	30.732	6.25	10	10	0.53	16.44	18.42	6.875	7.5	4.928	5.75	347

#### Low Speed (1500-2000 RPM) 3 Phase - 380-480V (460V Nominal Voltage)

Pump Size	e-1531X PN	Frame	NEMA Frame	A	B	CP	D	2E	F (Max)	H	L	O	DD	X	Y	Z	Weight (lbs)
1.25AD	1531XA1J5S..	S	143JM	6.84	6.34	21.295	3.5	5.5	5	0.34	10.75	11.12	4.75	5	3.25	4.5	105
1.5AD	1531XB1J5S..	S	143JM	6.84	6.34	21.17	3.5	5.5	5	0.34	10.625	11.12	5	6	3.125	4.625	120
1.25BC	1531XA4K5S..	L	213JM	10.04	8.42	24.015	5.25	8.5	7	0.41	12.375	14.73	6.125	8	3.25	5.5	197
1.5BC	1531XB4L5S..	S	213JM	10.04	8.42	23.89	5.25	8.5	7	0.41	12.25	14.73	6.25	6.5	3.125	5.75	194
1.5BC	1531XB4K5S..	S	213JM	10.04	8.42	23.89	5.25	8.5	7	0.41	12.25	14.73	6.25	6.5	3.125	5.75	194
2.5AC	1531XD2K5S..	S	213JM	10.04	8.42	25.2	5.25	8.5	7	0.41	13.56	14.73	5.813	6	4.5	4.688	197
2AD	1531XC1J5S..	S	143JM	6.84	6.34	21.67	3.5	5.5	5	0.34	11.125	11.12	5.5	6.5	3.5	4.75	137
2BD	1531XC5L5S..	S	213JM	10.04	8.42	24.89	5.25	8.5	7	0.41	13.25	14.73	6.875	7	4	5.875	202
2BD	1531XC5K5S..	S	213JM	10.04	8.42	24.89	5.25	8.5	7	0.41	13.25	14.73	6.875	7	4	5.875	202
2.5BB	1531XD4R5S..	L	254JM	12.5	12.4	27.602	6.25	10	10	0.53	13.31	18.42	7.25	6.75	4	6	301
2.5BB	1531XD4L5S..	S	213JM	10.04	8.42	26.45	5.25	8.5	7	0.41	14.81	14.73	7.25	6.75	4	6	226
3AD	1531XE1K5S..	S	215JM	10.04	8.42	25.2	5.25	8.5	7	0.41	13.56	14.73	6.25	6	4.125	5	216
3BD	1531XE5M5S..	L	254JM	12.5	12.4	30.102	6.25	10	10	0.53	15.81	18.42	7	7.5	4.75	6.125	320
3BD	1531XE5R5S..	L	254JM	12.5	12.4	30.102	6.25	10	10	0.53	15.81	18.42	7	7.5	4.75	6.125	320
4AD	1531XF1L5S..	S	213JM	10.04	8.42	26.58	5.25	8.5	7	0.41	14.94	14.73	6.875	7.5	4.928	5.75	272
4BD	1531XF5M5S..	L	254JM	12.5	12.4	30.417	6.25	10	10	0.53	16.125	18.42	8.625	8	5	7	361
5A	1531XG3R5S..	L	254JM	12.5	12.4	32.23	6.25	10	10	0.53	17.938	18.42	7.875	8.5	5.188	6.25	397
5BD	1531XG5M5S..	L	254JM	12.5	12.4	31.792	6.25	10	10	0.53	17.5	18.42	9.5	10	6	7.5	449
6BD	1531XH5M5S..	L	254JM	12.5	12.4	33.667	6.25	10	10	0.53	19.375	18.42	10.375	10.5	7	8.25	563

## Series e-1531X & e-1532X

### e-1531X - DIMENSIONS AND WEIGHTS

(All dimensions in inches and weights in lbs. Do not use for construction purposes.)

#### Low Speed (1500-2000 RPM) 3 Phase - 200-240V (230V Nominal Voltage)

Pump Size	e-1531X PN	Frame	NEMA Frame	A	B	CP	D	2E	F (Max)	H	L	O	DD	X	Y	Z	Weight (lbs)
1.25AD	1531XA1J5R..	S	143JM	6.84	6.34	21.295	3.5	5.5	5	0.34	10.75	11.12	4.75	5	3.25	4.5	105
1.5AD	1531XB1J5R..	S	143JM	6.84	6.34	21.17	3.5	5.5	5	0.34	10.625	11.12	5	6	3.125	4.625	120
1.25BC	1531XA4K5R..	L	213JM	10.04	8.42	24.015	5.25	8.5	7	0.41	12.375	14.73	6.125	8	3.25	5.5	197
1.5BC	1531XB4L5R..	S	213JM	10.04	8.42	23.89	5.25	8.5	7	0.41	12.25	14.73	6.25	6.5	3.125	5.75	194
1.5BC	1531XB4K5R..	S	213JM	10.04	8.42	23.89	5.25	8.5	7	0.41	12.25	14.73	6.25	6.5	3.125	5.75	194
2.5AC	1531XD2K5R..	S	213JM	10.04	8.42	25.2	5.25	8.5	7	0.41	13.56	14.73	5.813	6	4.5	4.688	197
2AD	1531XC1J5R..	S	143JM	6.84	6.34	21.67	3.5	5.5	5	0.34	11.125	11.12	5.5	6.5	3.5	4.75	137
2BD	1531XC5L5R..	S	213JM	10.04	8.42	24.89	5.25	8.5	7	0.41	13.25	14.73	6.875	7	4	5.875	202
2BD	1531XC5K5R..	S	213JM	10.04	8.42	24.89	5.25	8.5	7	0.41	13.25	14.73	6.875	7	4	5.875	202
2.5BB	1531XD4R5R..	L	254JM	12.5	12.4	27.602	6.25	10	10	0.53	13.31	18.42	7.25	6.75	4	6	301
2.5BB	1531XD4L5R..	S	213JM	10.04	8.42	26.45	5.25	8.5	7	0.41	14.81	14.73	7.25	6.75	4	6	226
3AD	1531XE1K5R..	S	215JM	10.04	8.42	25.2	5.25	8.5	7	0.41	13.56	14.73	6.25	6	4.125	5	216
3BD	1531XE5M5R..	L	254JM	12.5	12.4	30.102	6.25	10	10	0.53	15.81	18.42	7	7.5	4.75	6.125	320
3BD	1531XE5R5R..	L	254JM	12.5	12.4	30.102	6.25	10	10	0.53	15.81	18.42	7	7.5	4.75	6.125	320
4AD	1531XF1L5R..	S	213JM	12.5	12.4	26.58	6.25	10	10	0.53	14.94	18.42	6.875	7.5	4.928	5.75	272
4BD	1531XF5M5R..	L	254JM	12.5	12.4	30.417	6.25	10	10	0.53	16.125	18.42	8.625	8	5	7	361
5A	1531XG3R5R..	L	254JM	12.5	12.4	32.23	6.25	10	10	0.53	17.938	18.42	7.875	8.5	5.188	6.25	397
5BD	1531XG5M5R..	L	254JM	12.5	12.4	31.792	6.25	10	10	0.53	17.5	18.42	9.5	10	6	7.5	449
6BD	1531XH5M5R..	L	254JM	12.5	12.4	33.667	6.25	10	10	0.53	19.375	18.42	10.375	10.5	7	8.25	563

### e-1531X Suction and Discharge Dimensions

Pump Size	Suction					Discharge				
	Size	OD	BC	No. Bolts	Bolt Size	Size	OD	BC	No. Bolts	Bolt Size
1.25AD	1.5" NPT					1.25" NPT				
1.5AD	2" NPT					1.5" NPT				
1.25BC	1.5" NPT					1.25" NPT				
1.5BC	2" NPT					1.5" NPT				
2.5AC	3	7.5	6	4	0.625	2.5	7	5.5	4	0.625
2AD	2.5	7	5.5	4	0.625	2	6	4.75	4	0.625
2BD	2.5	7	5.5	4	0.625	2	6	4.75	4	0.625
2.5BB	3	7.5	6	4	0.625	2.5	7	5.5	4	0.625
3AD	4	9	7.5	8	0.625	3	7.5	6	4	0.625
3BD	4	9	7.5	8	0.625	3	7.5	6	4	0.625
4AD	5	10.75	8.5	8	0.75	4	9.5	7.5	8	0.625

Pump Size	Suction					Discharge				
	Size	OD	BC	No. Bolts	Bolt Size	Size	OD	BC	No. Bolts	Bolt Size
4BD	5	10	8.5	8	0.75	4	9	7.5	8	0.625
5A	6	12.125	9.5	8	0.75	5	10.75	8.5	8	0.75
5BD	6	12.125	9.5	8	0.75	5	10.75	8.5	8	0.75
6BD	8	14.75	11.75	8	0.75	6	12.125	9.5	8	0.75
2EB	3	8.25	6	4	0.63	2	6.5	4.75	4	0.63
3EB	4	10	7.5	8	0.63	3	8.25	6	4	0.63
4EB	5	11	8.5	8	0.63	4	10	7.5	8	0.63
5EB	6	12.5	9.5	8	0.75	5	11	8.5	8	0.75
2GB	3	8.25	6	4	0.63	2	6.5	4.75	4	0.63
3GB	4	10	7.5	8	0.63	3	8.25	6	4	0.63
4GC	5	11	8.5	8	0.75	4	10	7.5	8	0.63

### e-1532X - DIMENSIONS AND WEIGHTS

(All dimensions in inches and weights in lbs. Do not use for construction purposes.)

#### e-1532X with NPT connections

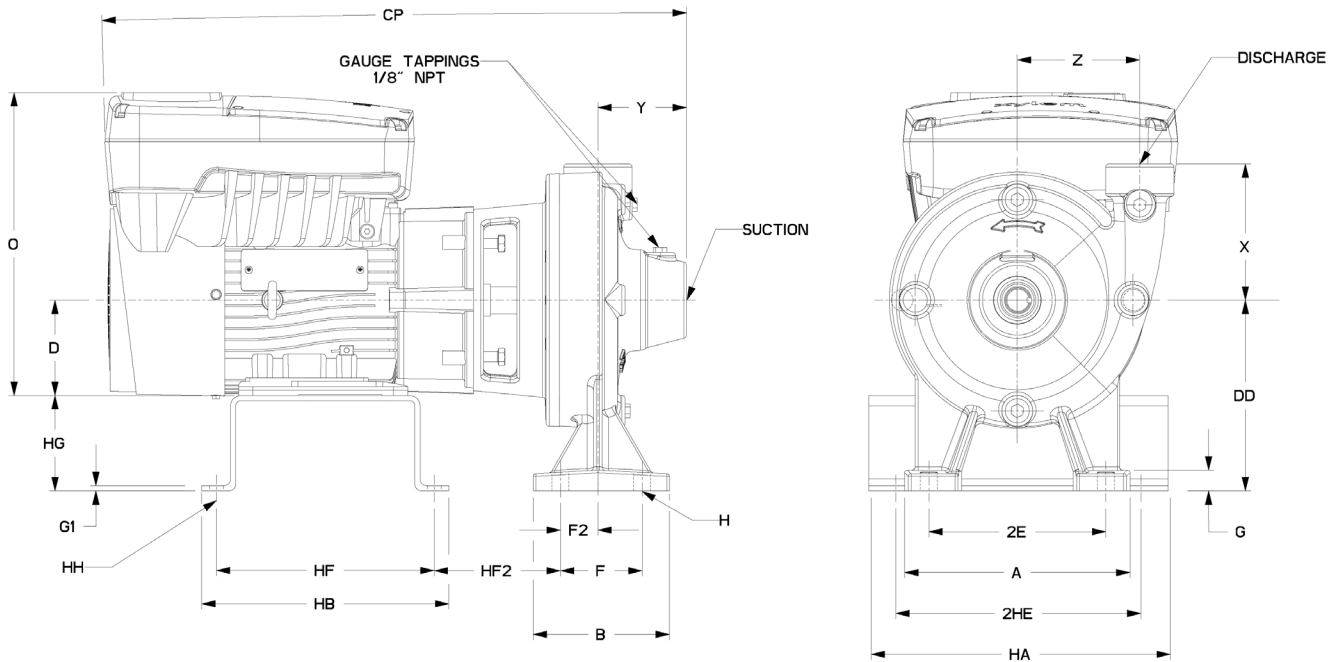

## Series e-1531X & e-1532X

### e-1532X - DIMENSIONS AND WEIGHTS

(All dimensions in inches and weights in lbs. Do not use for construction purposes.)

#### e-1532X with ANSI 125# flanged connections

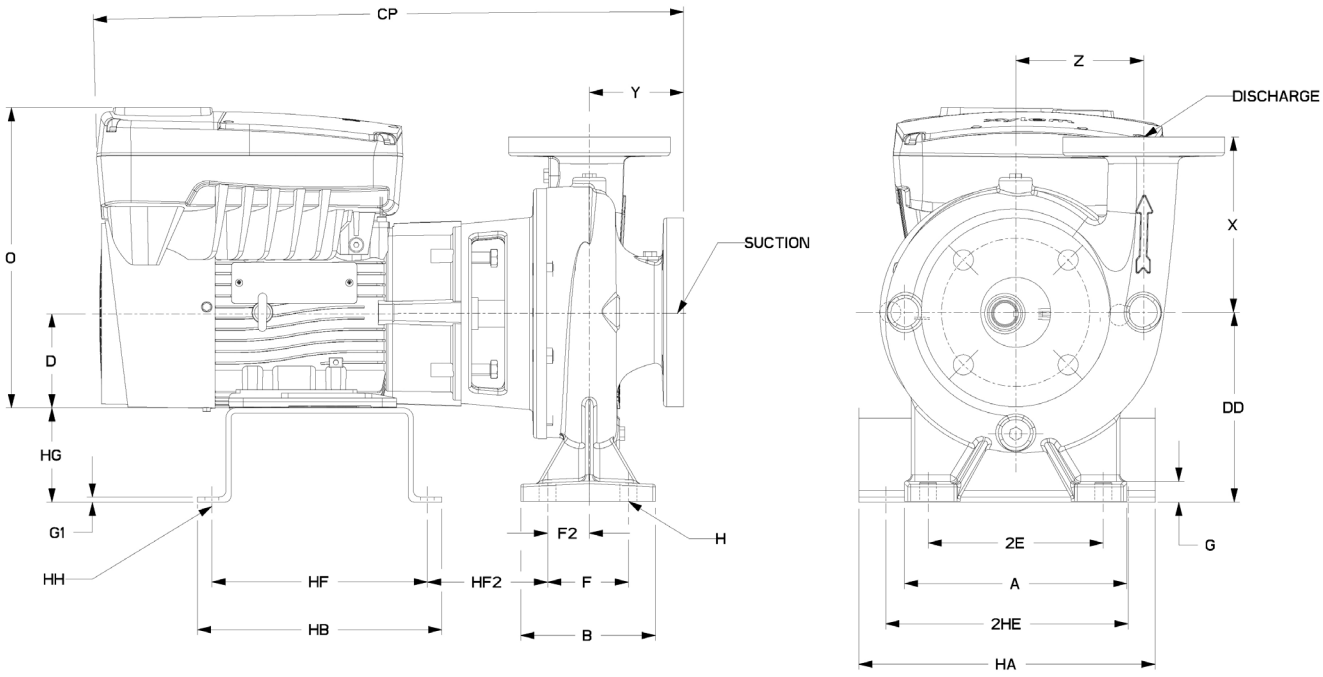

### High Speed (3000-4000 RPM) 3 Phase - 380-480V (460V Nominal Voltage)

Pump Size	e-1531X PN	Frame	NEMA Frame	A	HB	CP	D	2E	HA	2HE	F	F2	HF	HF2	H	HG	G	G1	HH	O	B	DD	X	Y	Z	Weight (lbs)
1.25AD	1531XA1M4S..	S	213JM	8	12	24.015	5.25	6.5	13.63	12.5	3	1.37	10.75	5.87	0.5	1.75	0.63	0.19	0.5	14.73	5	7	5	3.25	4.5	180
1.25AD	1531XA1L4S..	S	143JM	8	10.88	21.295	3.5	6.5	11	9.75	3	1.37	9.63	3.81	0.63	3.5	0.63	0.19	0.5	11.12	5	7	5	3.25	4.5	123
1.5AD	1531XB1N4S..	L	254JM	8	15.5	28.042	6.25	6.5	13.63	12.5	3	1.42	14.25	7.1	0.63	1.75	1.64	0.19	0.5	18.42	5	8	6	3.125	4.625	279
1.5AD	1531XB1R4S..	S	213JM	8	12	23.89	5.25	6.5	13.63	12.5	3	1.42	10.75	5.83	0.63	1.75	0.64	0.19	0.5	14.73	5	7	6	3.125	4.625	204
1.25BC	1531XA4Q4S..	L	254JM	11	15.5	28.167	6.25	9.13	13.63	12.5	4.38	1.42	14.25	7.08	0.63	1.75	0.69	0.19	0.5	18.42	6	8	8	3.25	5.5	299
1.5BC	1531XB4Q4S..	L	254JM	11	15.5	28.042	6.25	9.13	13.63	12.5	4.38	1.42	6.25	7.1	0.63	1.75	0.69	0.19	0.5	18.42	6	8	6.5	3.125	5.75	303
2.5AC	1531XD2P4S..	L	254JM	8	15.5	29.352	6.25	6.5	13.63	12.5	3	1.62	14.25	7.07	0.63	1.75	1.63	0.19	0.5	18.42	5	8	6	4.25	4.688	308
2.5AC	1531XD2M4S..	S	213JM	8	12	25.2	5.25	6.5	13.63	12.5	3	1.62	10.75	5.81	0.63	1.75	0.63	0.19	0.5	14.73	5	7	6	4.25	4.688	233
2AD	1531XC1P4S..	L	254JM	8	15.5	28.542	6.25	6.5	13.63	12.5	3	1.55	14.25	7.1	0.63	1.75	1.63	0.19	0.5	18.42	5	8	6.5	3.5	4.75	295
2AD	1531XC1R4S..	S	213JM	8	12	24.39	5.25	6.5	13.63	12.5	3	1.55	10.75	5.83	0.63	1.75	0.63	0.19	0.5	14.73	5	7	6.5	3.5	4.75	220
2BD	1531XC5Q4S..	L	254JM	11	15.5	29.042	6.25	9.13	13.63	12.5	4.38	1.55	14.25	7.08	0.63	1.75	0.69	0.19	0.5	18.42	6	8	7	4	5.875	318
2BD	1531XC5N4S..	L	254JM	11	15.5	29.042	6.25	9.13	13.63	12.5	4.38	1.55	14.25	7.08	0.63	1.75	0.69	0.19	0.5	18.42	6	8	7	4	5.875	318
3AD	1531XE1Q4S..	L	254JM	8	15.5	29.292	6.25	6.5	13.63	12.5	3	1.69	14.25	7.07	0.63	1.75	1.63	0.19	0.5	18.42	5	8	6	4.125	5	317
3AD	1531XE1P4S..	L	254JM	8	15.5	29.292	6.25	6.5	13.63	12.5	3	1.69	14.25	7.07	0.63	1.75	1.63	0.19	0.5	18.42	5	8	6	4.125	5	317
4AD	1531XF1Q4S..	L	254JM	11	15.5	30.732	6.25	9.13	13.63	12.5	4.38	2.25	14.25	6	0.63	1.75	0.69	0.19	0.5	18.42	6	8	7.5	4.928	5.75	371







**NOTES**

# Xylem |'zīləm|

- 1) The tissue in plants that brings water upward from the roots;
- 2) a leading global water technology company.

We're a global team unified in a common purpose: creating advanced technology solutions to the world's water challenges. Developing new technologies that will improve the way water is used, conserved, and re-used in the future is central to our work. Our products and services move, treat, analyze, monitor and return water to the environment, in public utility, industrial, residential and commercial building services settings. Xylem also provides a leading portfolio of smart metering, network technologies and advanced analytics solutions for water, electric and gas utilities. In more than 150 countries, we have strong, long-standing relationships with customers who know us for our powerful combination of leading product brands and applications expertise with a strong focus on developing comprehensive, sustainable solutions.

**For more information on how Xylem can help you, go to [www.xylem.com](http://www.xylem.com)**

Learn more about Series  
e-1531X and e-1532X Smart Pumps



#### Xylem Product Cybersecurity:

Xylem values your system security and the availability of your critical services. For more information on Xylem cybersecurity practices or to contact the cybersecurity team please visit [xylem.com/security](http://xylem.com/security).



Xylem Inc.  
8200 N. Austin Avenue  
Morton Grove, Illinois 60053  
Phone: (847) 966-3700  
Fax: (847) 965-8379  
[www.xylem.com/bellgossett](http://www.xylem.com/bellgossett)

Xylem, Bell & Gossett and Hydrovar are registered trademarks of Xylem Inc. or one of its subsidiaries. MODBUS is a registered trademark of Schneider Electric USA, Inc. The Bluetooth word mark and logos are registered trademarks owned by Bluetooth SIG, Inc. and any use of such marks by Xylem Inc. or one of its subsidiaries is under license. All other trademarks or registered trademarks are the property of their respective owners.