

**xylem**  
Let's Solve Water



# AGS Series

Axial Grinder Pumps

POWERFUL PERFORMANCE FOR THE  
MODERN WASTEWATER STREAM

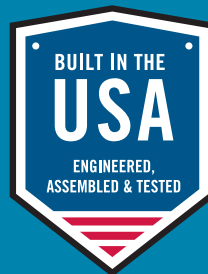

BRAGSSERIES R7

**GOULDS**  
WATER TECHNOLOGY  
a xylem brand

## Based on technology developed and tested in the toughest wastewater environments, count on the AGS Series axial grinder pumps to handle the challenging demands of today's residential wastewater.

The AGS Series grinder pumps feature a powerful axial grinder and semi-open impeller technology to easily slice through the solids, flushables and trash found in the modern wastewater stream without roping or clogging. This technology reduces waste to a fine slurry, resulting in minimal downtime and service issues. The AGS Series axial grinder pumps available through Goulds Water Technology offer proven solutions for a range of residential applications.

### APPLICATIONS

- 2" Sewage pump replacement (.5 hp & 1 hp)
- Residential and small office new construction (wastewater)
- Areas where modern wastewater flushables are creating clogging issues

### ADVANTAGES

**Proven design:** The axial grinder and semi-open impeller technology reduce downtime caused by clogging or roping.

**Broad range of solutions:** Available in single phase 0.5 hp (115V or 208-230V), 1 hp (115V or 208-230V) and 2 hp (208-230V) options.

**Trusted performance:** Models deliver up to 120' TDH and flow rates of 53 gpm.

**Ease of installation:** Fixed balanced attachment to help simplify installation.

**Built to last:** Stainless steel (440C), cutter/plate style configuration and oil cooled motor. Cast iron impeller.

**Continuous operation:** Pump ratings are within the motor manufacturer's recommended working limits and can be operated continuously without damage when fully submerged. Single phase, built-in, auto reset overload (Class F insulation) on all models.

**Warranty:** Three (3) years standard. Backed by Goulds Water Technology service and support. Four (4) years for GPDA members



# Built to Perform

## FEATURES

- A. Casing:** One piece, uni-body cast iron, volute type for high efficiency.
- B. Axial grinder:** Stainless steel, eight (8) hole cutter plate, three (3) blade cutter generating up to 4.9 million bites per hour (up to 120' TDH).
- C. Semi-open impeller:** Powerful, non-clogging, cast iron design. Balanced for smooth operation.
- D. Motor:** Oil-cooled/fully submerged in high grade turbine oil for more efficient heat dissipation, permanent lubrication of bearings and mechanical seal, and protection against outside environment.
- E. Motor shaft:** AISI 300 series stainless steel.
- F. Bearing housing/bearings:** Upper and lower ball bearings for precision positioning of parts and to carry all radial and thrust loads.
- G. Mechanical seal:** Hardfaced silicon carbide on silicon carbide for longer life, stainless steel metal parts, BUNA-N elastomers (standard feature).
- H. Power cord:** Severe duty rated, oil and water resistant 20 foot cord. SJTOW power cord with NEMA three prong grounding plug.
- I. Fixed balanced handle:** For ease of installation.
- **Available in automatic and manual models**

**Axial Grinder Technology:** Stainless steel, non-clogging design. Generates up to 4.9 million bites per hour (up to 120' TDH).

J. Eight (8) hole cutter plate.

K. Three (3) blade cutter with advanced design features to provide superior performance.

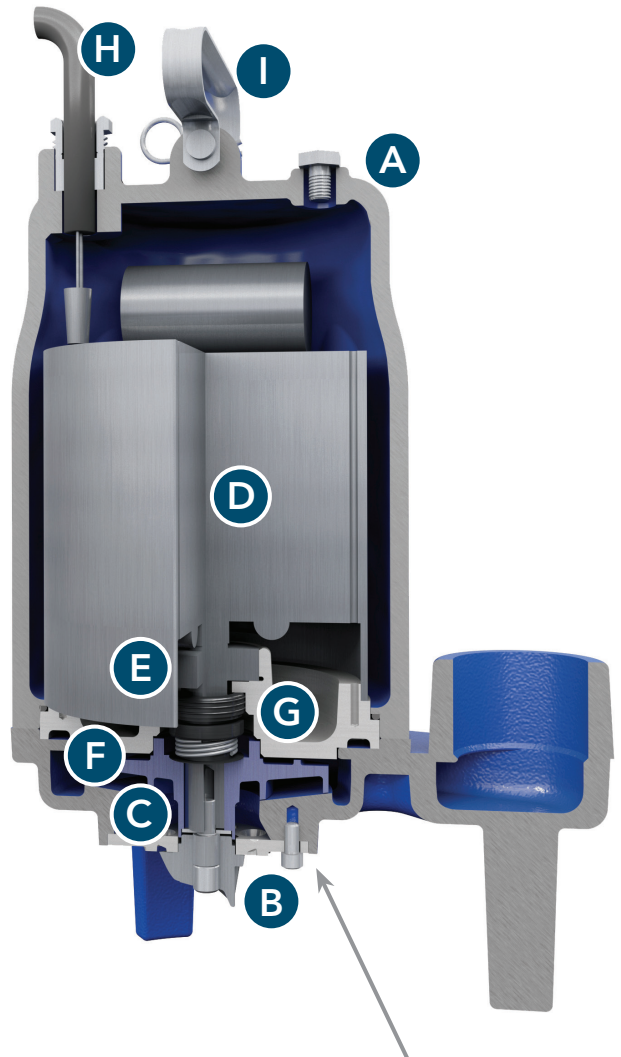

**COMPLETE. RELIABLE. BLUE.**  
 Learn more about our complete line of wastewater products.



# AGS Series Axial Grinder Pumps

## PERFORMANCE CURVE

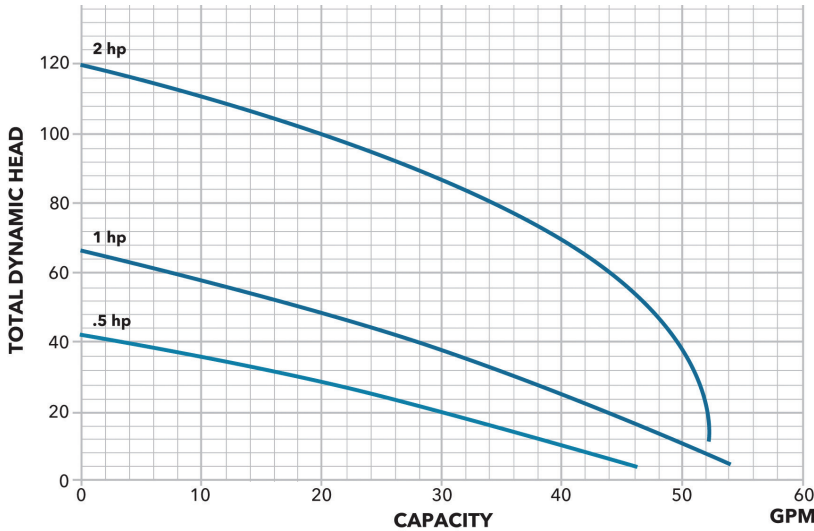

## SPECIFICATIONS

	AGS0511*	AGS0512*	AGS1011*	AGS1012*	AGS2012
Voltage	115	208-230	115	208-230	
Amps	9A	4.5A	11A	5.5A	15A
HP	0.5		1		2
Capacity	46 gpm		53 gpm		52 gpm
Head	42 feet, TDH		66 feet, TDH		120 feet, TDH
Grinder	Axial, Stainless Steel (440C)				
Cutter Plate	8 Hole, 3 Blade, Stainless Steel (440C) (cutter)				
Bites Per Hour	4.9 Million				
Impeller	Semi-Open, Cast Iron				
Phase	Single				
Speed	3500 rpm				
Discharge	2"			1 1/4"	
Motor	Oil Cooled, CSCR				
Casing	Uni body, Class 30 Cast Iron				
Shaft	Stainless Steel, 300 Series SS				
Bearings	Upper/Lower Sealed Ball Bearings				
Hz	60				
Seal	Hardfaced Silicon Carbide on Silicon Carbide				
Cord	20 feet				
Insulation	Class F				
Weight	65 lbs			96 lbs	
Warranty	3 Year				

\* Piggyback float can be purchased separately or get the float with the pump by adding the suffix "PB" to each pump. Ex. AGS0511PB is the pump with a 115V 20' Cord Piggyback N/O Mechanical Float Switch.

## DIMENSIONAL DRAWINGS

All dimensions are in inches. Do not use for construction purposes.

### AGS 0511, 0512, 1011 & 1012:

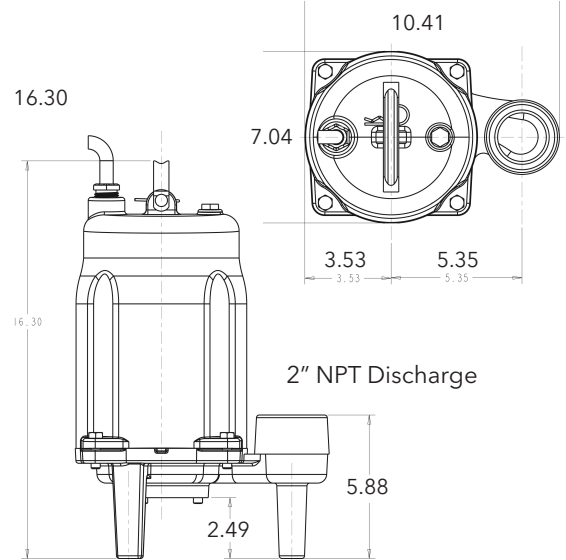

### AGS 2012:

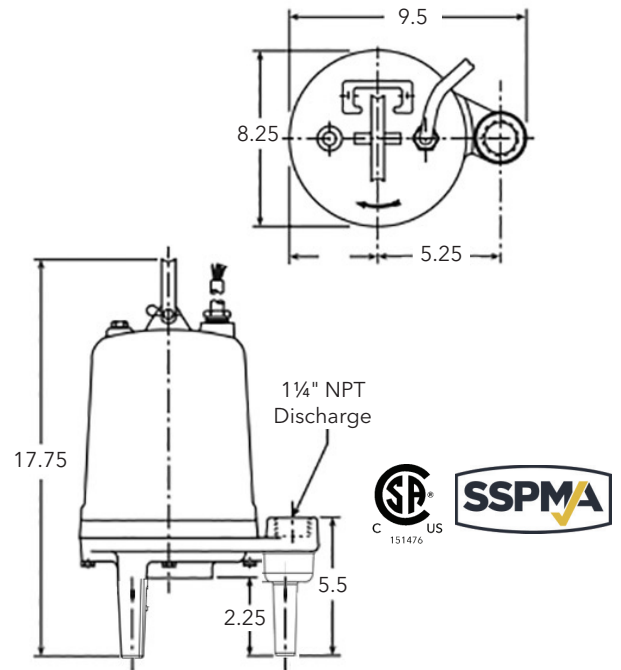

Learn more about AGS Series Pumps & Packages



Xylem Inc.  
www.xylem.com/goulds

Xylem is a registered trademark of Xylem Inc. or one of its subsidiaries. Goulds is a registered trademark of ITT Manufacturing Enterprises LLC and is used under license. All other trademarks or registered trademarks are property of their respective owners.  
© 2024 Xylem BRAGSSERIES R7 August 2024