



Series e-SHX Smart Pump

Integrated pump, motor & variable speed drive solutions, **powered by hydrovar® X**

Ultra-premium package bringing market-leading performance right out of the box!

Powered by Xylem's hydrovar® X Smart Motor, e-SHX Smart Pumps offer customizable pumping solutions designed to deliver ultra-premium efficiency, connectivity, and simplicity right out of the box!

e-SHX Smart Pumps integrate decades of expertise and know-how in pumping solutions to bring the right combination of motors, variable speed drive and hydraulic pumps in one comprehensive, highly efficient package.

e-SHX Smart Pumps feature AISI 316 stainless steel construction for reduced corrosion and improved strength and ductility. Each pump comes equipped with interchangeable mechanical seals. The back pull-out design simplifies maintenance by allowing the impeller, bracket and motor to be extracted without disconnecting the pump body from the piping. Suction and discharge flanges mate easily with ANSI class 150 flanges. The e-SHX can handle liquid temperatures up to 250° F. Pumps assembled at the factory are certified to the NSF/ANSI 61 Drinking Water System Components Standard.

So, when it's time to think efficiency, performance and reliable market-leading technology ... start with e-SHX Smart Pumps from Goulds Water Technology - a complete system, delivering the solutions you need for today.

e-SHX Smart Pump applications and standard features

For more than a century, Xylem's pump technologies and solutions have satisfied customers all over the world. The e-SHX Smart Pump continues that tradition, with higher efficiencies and proven performance in a wide range of industrial and commercial building applications. Here are just a few of the markets and applications in which we're already helping customers solve their water and fluid management challenges:

Applications

- Water intake
- Water transfer and circulation
- Pressure boosting
- Process cooling and heating
- Fluid transfer and transport
- Produced water transfer and boosting
- Boiler feed booster

Pumped fluids

- Groundwater
- Potable water
- Process water
- Gray/used water
- Heat transfer fluids
- Produced water

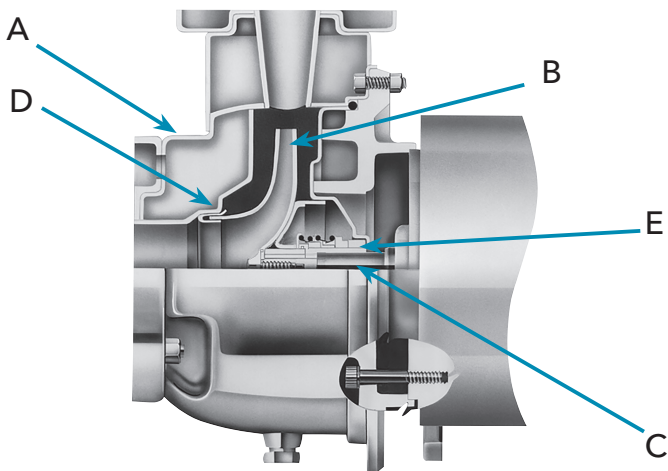

- A. Casing** - durable 316 SS to handle a diverse range of pumped fluids
- B. Stainless steel impeller** - resists corrosion to maintain performance and minimize downtime
- C. Shaft sleeve** - replaceable 316 SS sleeves minimize shaft wear
- D. Replaceable wear rings** - to maximize efficiency through the total life of the pump
- E. Mechanical seal** - interchangeable mechanical seals with a variety of materials for multiple applications

Performance

(representative example of increased performance with hydrovar X)

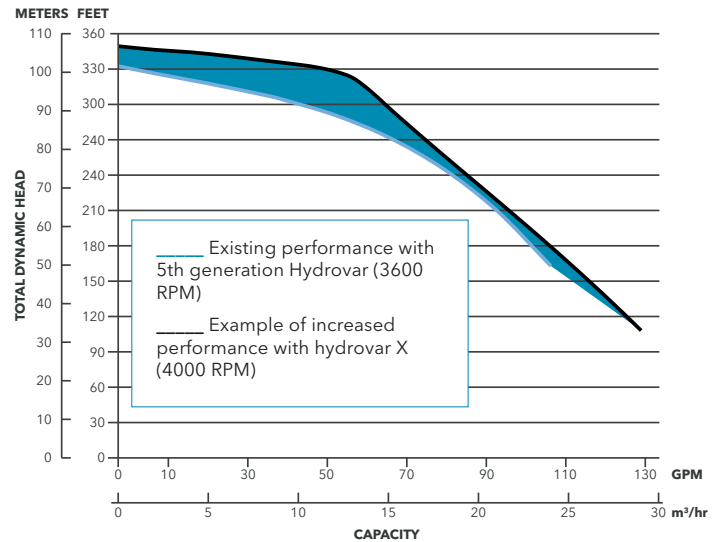

Unleash the power of hydrovar X!

Don't hold back your imagination!

With the graphical color display, you can quickly set-up and navigate the menu of your unit: check all the parameters and choose the perfect unit configuration to fit your installation. No time to do it? Genie will start up and run the unit for you!



Check your systems from wherever

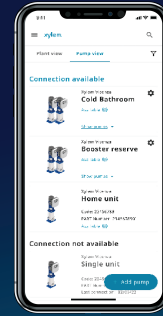

Download the mobile app



hydrovar X and Avensor, better together!

hydrovar X can communicate with Avensor, Xylem's IoT platform, for a complete overview of all connected assets, anytime, anywhere. Avensor collects historical data to analyze trends and generate alerts preventing failures and equipment downtime.

Simple: Built-in application software makes the drive one of the easiest to commission, program and operate, enabling virtually any configuration of pumps.

Sustainable: No rare earth materials are used to minimize product availability challenges and address environmental concerns while offering smart technology and superior performance.

Intelligent performance: Advanced system controls (up to 8 pumps) are customizable for a wide range of applications. The IE5 "ultra-premium" hydrovar X smart motor provides one of the broadest efficiency ranges in the industry.

Built-in protections: Integrated functions provide protection for the pump and motor while optimizing performance.

Compact motor design: e-SHX Smart Pumps offer increased performance to 4000 RPM, reduce electricity consumption and lower life cycle costs.

Easy service: Separate quick connect components allow users to replace the drive or the motor independently minimizing downtime and expensive repair. The integrated electrical socket requires no additional wiring, allowing a true plug and play solution versus buying a new motor and drive combination.

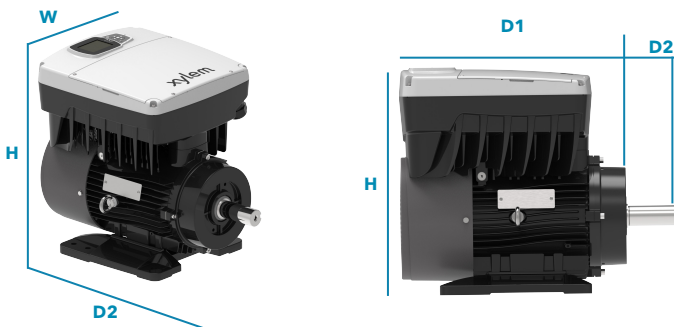

hydrovar X Smart Motor Dimensions

Motor Power HP (kW)	NEMA Frame	H in [mm]	W in [mm]	D1 in [mm]	D2 in [mm]
4-7.5 (3-5.5)	143-145JM	11.1 (282)	10.9 (276)	13.5 (344)	17.8 (452)
7.5-15 (5.5-11)	213-215JM	14.7 (374)	13.0 (330)	16.1 (410)	20.4 (518)
15-30 (11-22)	254-256JM	18.4 (468)	15.2 (385)	19.3 (490)	24.5 (623)

Product Specifications

hydrovar X Smart Motor Specifications

Display:	Graphic color
Controls modes:	Actuator, Constant Pressure. Proportional Pressure, Proportional Quadratic Pressure, Constant Flow, Constant Temperature, Constant Level
Multi-pump:	up to 8 pumps
Enclosure:	IP55/NEMA4
Working temperature:	-4°/+122°F (-20°/+50°C)
Communication protocols:	MODBUS® RTU, BACnet MS/TP
Features:	IE5 synchronous motor
Mobile app:	Bluetooth®

e-SHX Smart Pump Specifications

Flow rate:	up to 970 GPM (220 m³/h)
Head:	up to 380 ft (116 m)
Temperature of pumped liquid:	up to 250°F (121°C)
Maximum operating pressure:	230 psi (16 bar)
Environment temperature:	-4°F to 122°F (-20°C to 50°C)

e-SHX Smart Pump Family Curves

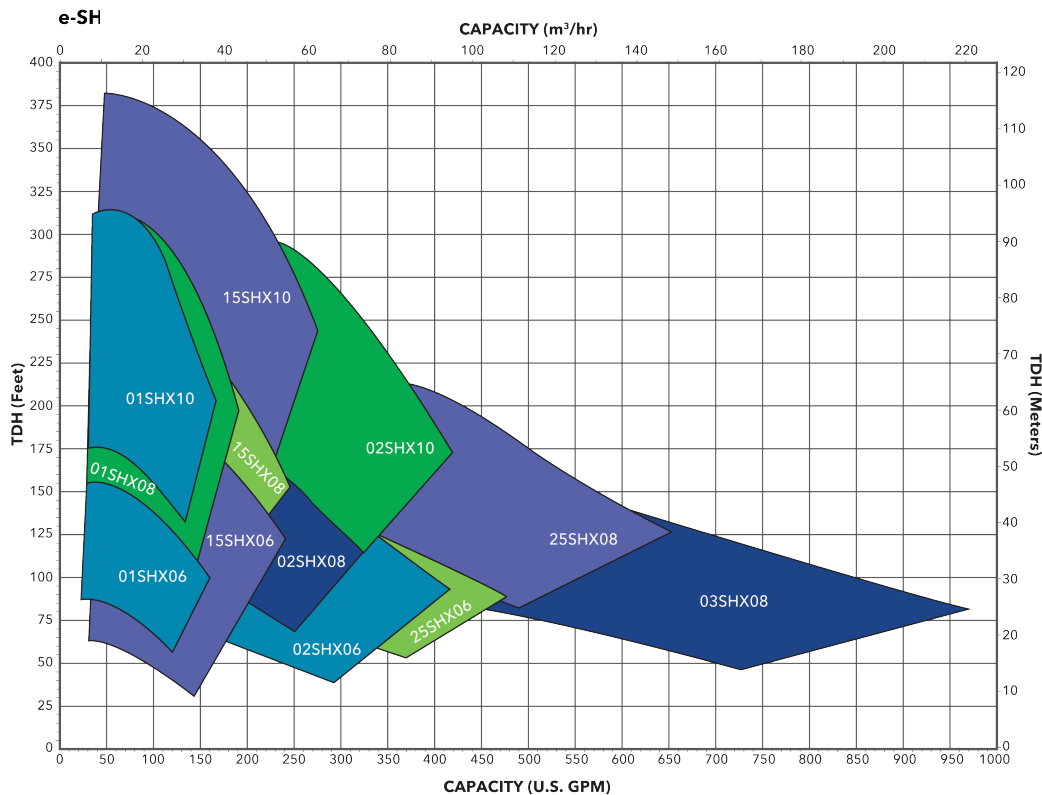

Xylem Product Cybersecurity

Xylem values your system security and the availability of your critical services. For more information on Xylem cybersecurity practices or to contact the cybersecurity team please visit www.xylem.com/security.

Xylem Inc.

Phone: (866) 673-0428

Fax: (888) 322-5877

www.xylem.com/goulds

Xylem reserves the right to make modification without prior notice.

Xylem and Hydrovar are registered trademark of Xylem Inc. or one of its subsidiaries.

MODBUS is a registered trademark of Schneider Electric USA, Inc. The Bluetooth word mark and logos are registered trademarks owned by Bluetooth SIG, Inc. and any use of such marks by Xylem Inc. or one of its subsidiaries is under license. All other trademarks or registered trademarks are property of their respective owners.



Learn more about e-SHX Smart Pumps

