



## Series e-SVX Smart Pump

Integrated pump, motor & variable speed drive solutions, **powered by hydrovar® X**

# Ultra-premium package bringing market-leading performance right out of the box!

Powered by Xylem's hydrovar® X Smart Motor, e-SVX Smart Pumps offer customizable pumping solutions designed to deliver ultra-premium efficiency, connectivity, and simplicity right out of the box!

e-SVX Smart Pumps integrate decades of expertise and know-how in pump technology to bring the right combination of motors, variable speed drive and hydraulic pumps in one comprehensive, highly efficient package. The e-SVX is built to withstand a variety of mechanically aggressive and high temperature liquids such as glycol, oils/solvents, and more. It features 10 different sizes and each can be specially configured for a wide range of environments. It's an ideal solution for residential, light commercial, industrial, agricultural, and OEM water supply as well as HVAC applications.

So, when it's time to think efficiency, performance and reliable market-leading technology ... start with e-SVX Smart Pumps from Goulds Water Technology - a complete system, delivering the solutions you need for today.

## Standard features of e-SVX Smart Pumps

The e-SV pump, the product at the heart of the e-SVX Smart Pump Series, is one of the highest efficiency multistage pumps on the market today. This fabricated vertical multistage pump is also easy to install and economical to maintain. When it comes to efficiency, all of the pumps in the e-SV product family deliver!

## Performance

(representative example of increased performance with hydrovar X)

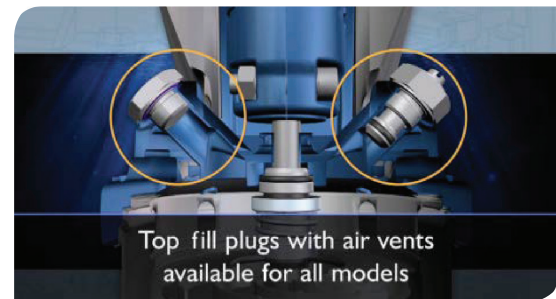
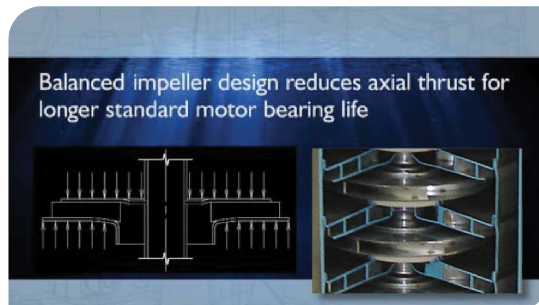
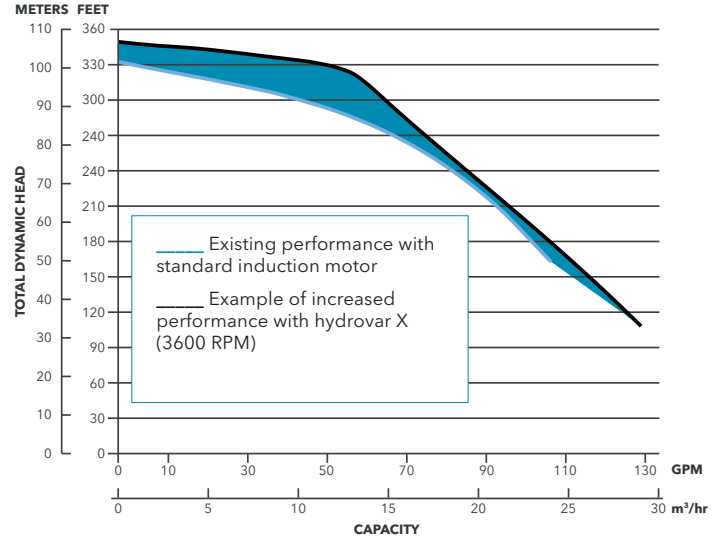

# Unleash the power of hydrovar X!

## Don't hold back your imagination!

With the graphical color display, you can quickly set-up and navigate the menu of your unit: check all the parameters and choose the perfect unit configuration to fit your installation. No time to do it? Genie will start up and run the unit for you!



## Check your systems from wherever

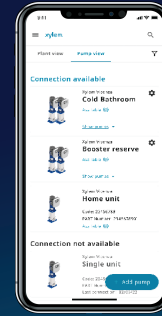

Download the mobile app



## hydrovar X and Avensor, better together!

hydrovar X can communicate with Avensor, Xylem's IoT platform, for a complete overview of all connected assets, anytime, anywhere. Avensor collects historical data to analyze trends and generate alerts preventing failures and equipment downtime.

**Simple:** Built-in application software makes the drive one of the easiest to commission, program and operate, enabling virtually any configuration of pumps.

**Sustainable:** hydrovar X is a smarter green technology solution. No rare earth materials are used to minimize product availability challenges and address environmental concerns while offering smart technology and superior performance with a "green heart".

**Intelligent performance:** Advanced system controls (up to 8 pumps) are customizable for a wide range of applications. The IE5 "ultra-premium" hydrovar X smart motor provides one of the broadest efficiency ranges in the industry.

**Ease of installation & maintenance:** Integrated pump and hydrovar X motor design eliminates the need for additional wiring, labor and associated costs.

**Built-in protections:** Integrated functions provide protection for the pump and motor while optimizing performance.

**Easy service:** VFD and/or motor can be easily replaced individually, minimizing downtime and expensive repair.

**Compact design:** hydrovar X motors offer higher performance with a reduced footprint when compared to the legacy Packaged Hydrovar solution. Increased performance reduces electricity consumption and lowers life cycle costs.



*Separate quick connect components allow users to replace the drive or the motor independently. The integrated electrical socket requires no additional wiring, allowing a true plug and play solution versus buying a new motor and drive combination.*

5<sup>th</sup> generation  
Hydrovar®

new design  
hydrovar® X

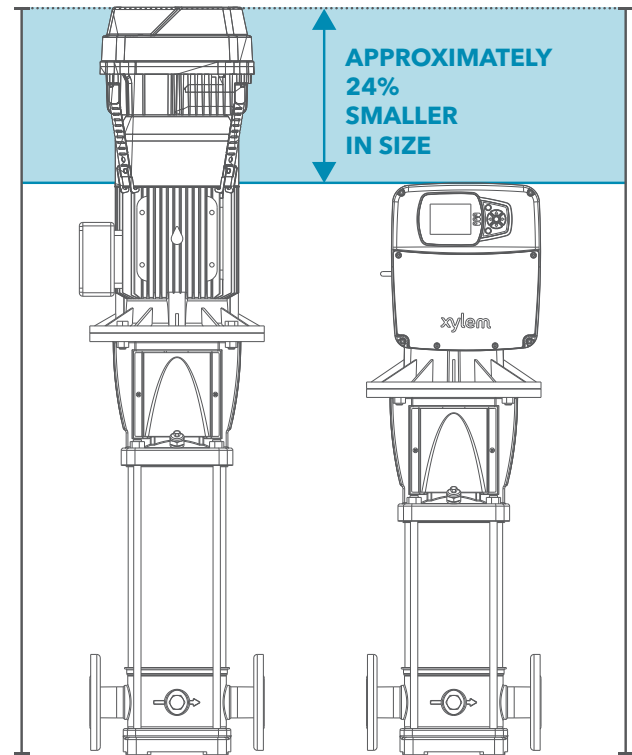

# Product Specifications

## hydrovar X Smart Motor Specifications

<b>Display:</b>	Graphic color
<b>Controls modes:</b>	Actuator, Constant Pressure. Proportional Pressure, Proportional Quadratic Pressure, Constant Flow, Constant Temperature, Constant Level
<b>Multi-pump:</b>	up to 8 pumps
<b>Enclosure:</b>	IP55/NEMA4
<b>Working temperature:</b>	-4°/+122°F (-20°/+50°C)
<b>Communication protocols:</b>	MODBUS® RTU, BACnet MS/TP
<b>Features:</b>	IE5 synchronous motor
<b>Mobile app:</b>	Bluetooth®

## hydrovar X Smart Motor Dimensions

Motor Power HP (kW)	H in (mm)	W in (mm)	D in (mm)
4 - 7.5 (3-5.5)	11.38 (289)	10.08 (256)	11.18 (284)
7.5 - 15 (5.5-11)	13 (329)	11.89 (302)	13.82 (351)
15 - 30 (11-22)	15.75 (400)	14.25 (362)	17.4 (442)

## e-SVX Smart Pump Specifications

<b>Flow rate:</b>	up to 640 GPM (145 m3/h)
<b>Head:</b>	up to 1200 ft (366 m)
<b>Temperature of pumped liquid:</b>	-20°F to 250°F (-30°C to 121°C)
<b>Maximum operating pressure:</b>	580 psi (40 bar)
<b>Environment temperature:</b>	-4°F to 122°F (-20°C to 50°C)



## e-SVX Smart Pump Family Curves

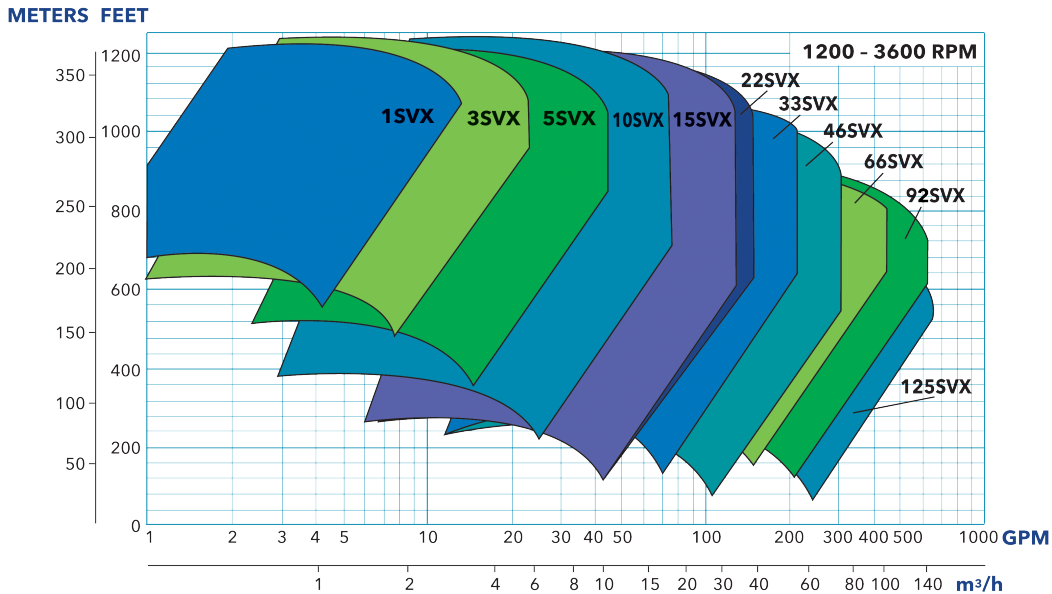

### Xylem Product Cybersecurity

Xylem values your system security and the availability of your critical services. For more information on Xylem cybersecurity practices or to contact the cybersecurity team please visit [www.xylem.com/security](http://www.xylem.com/security).



Xylem Inc.  
 Phone: (866) 673-0428  
 Fax: (888) 322-5877  
[www.xylem.com](http://www.xylem.com)

Xylem reserves the right to make modification without prior notice. Xylem and Hydrovar are registered trademark of Xylem Inc. or one of its subsidiaries. MODBUS is a registered trademark of Schneider Electric USA, Inc. The Bluetooth word mark and logos are registered trademarks owned by Bluetooth SIG, Inc. and any use of such marks by Xylem Inc. or one of its subsidiaries is under license. All other trademarks or registered trademarks are property of their respective owners.

Learn more about e-SVX Smart Pumps:

