

Additional Installation, Operation
and Maintenance Instructions



Smart Pump Range

e-SVE, VME, e-HME, e-SVIE



See also:

- Quick Startup Guide
- e-SVE, VME, e-HME, e-SVIE
Installation and Operation Manual

Table of Contents

| | | |
|-------|---|----|
| 1 | Introduction and Safety | 4 |
| 1.1 | Introduction..... | 4 |
| 1.2 | Safety | 4 |
| 1.2.1 | Hazard levels and safety symbols..... | 4 |
| 1.2.2 | User safety | 5 |
| 1.2.3 | General safety rules | 6 |
| 1.2.4 | Protection of the environment | 7 |
| 1.2.5 | Sites exposed to ionizing radiations..... | 7 |
| 1.3 | Spare parts..... | 7 |
| 1.4 | Product warranty | 7 |
| 2 | Handling and Storage | 8 |
| 2.1 | Unit handling | 8 |
| 2.2 | Storage..... | 10 |
| 3 | Technical Description..... | 11 |
| 3.1 | Designation | 11 |
| 3.2 | Data plates | 11 |
| 3.2.1 | Motor | 11 |
| 3.2.2 | e-HME and VME pumps | 12 |
| 3.2.3 | e-SVE pump..... | 14 |
| 3.2.4 | e-SVIE pump..... | 15 |
| 3.3 | Design and layout..... | 17 |
| 3.4 | Intended use..... | 19 |
| 3.4.1 | Application alternatives | 19 |
| 3.5 | Improper use | 19 |
| 4 | Installation..... | 20 |
| 4.1 | Mechanical installation | 20 |
| 4.1.1 | Installation area | 20 |
| 4.1.2 | Unit installation | 20 |
| 4.1.3 | Outdoor unit installation | 21 |
| 4.2 | Hydraulic installation | 22 |
| 4.3 | Electrical Installation | 23 |
| 4.3.1 | Electrical requirements..... | 23 |
| 4.3.2 | Wire types and ratings..... | 24 |
| 4.3.3 | Power supply connection | 25 |
| 5 | Operation | 29 |
| 5.1 | Wait times..... | 29 |
| 6 | Programming | 30 |
| 6.1 | Control panel..... | 30 |
| 6.2 | Description of the buttons | 31 |

| | | |
|-------|---|----|
| 6.3 | LEDs description | 31 |
| 6.3.1 | POWER (power supply) | 31 |
| 6.3.2 | STATUS | 31 |
| 6.3.3 | SPEED (speed bar)..... | 31 |
| 6.3.4 | COM (communication) | 32 |
| 6.3.5 | Unit of measurement..... | 32 |
| 6.4 | Display..... | 33 |
| 6.4.1 | Main visualization | 33 |
| 6.4.2 | Parameters menu visualization | 34 |
| 6.4.3 | Alarms and errors visualization | 35 |
| 6.5 | Software parameters | 35 |
| 6.5.1 | Status Parameters..... | 35 |
| 6.5.2 | Settings Parameters..... | 36 |
| 6.5.3 | Drive Configuration Parameters..... | 37 |
| 6.5.4 | Sensor Configuration Parameters..... | 39 |
| 6.5.5 | RS485 Interface Parameters..... | 40 |
| 6.5.6 | Multi-pump configuration parameters..... | 40 |
| 6.5.7 | Test Run Configuration Parameters..... | 41 |
| 6.5.8 | Special Parameters | 41 |
| 6.6 | Technical references | 42 |
| 6.6.1 | Example: ACT control mode with analog input | 42 |
| 6.6.2 | Example: Ramp Settings | 43 |
| 6.6.3 | Example: Effective Required Value..... | 43 |
| 7 | Maintenance | 45 |
| 8 | Troubleshooting | 46 |
| 8.1 | Alarm codes | 46 |
| 8.2 | Error codes..... | 46 |
| 9 | Technical Information..... | 48 |
| 9.1 | Dimensions and weights | 49 |
| 10 | Disposal..... | 52 |
| 10.1 | Precautions | 52 |
| 10.2 | WEEE (EU/EEA) | 52 |
| 10.3 | WEEE (UK) | 52 |
| 11 | Declarations | 53 |
| 11.1 | EC Declaration of Conformity (Original)..... | 53 |
| 11.2 | EU Declaration of Conformity (No 19)..... | 53 |
| 11.3 | UKCA Declaration of Conformity (Original)..... | 54 |
| 11.4 | UKCA Declaration of Conformity (No 19) | 54 |

1 Introduction and Safety

1.1 Introduction

Purpose of this manual

The purpose of this manual is to provide necessary information for:

- Installation
- Operation
- Maintenance



CAUTION:

Before installing and using the product, make sure that you read and fully understand this manual in all its parts. Improper use of the product can cause personal injuries and damage to property, as well as making the warranty null and void.

NOTE:



This manual is an integral part of the product. It must always be made available to the user, stored in the proximity of the product, and well kept.

1.2 Safety

Before using the product, and in order to avoid the following risks, make sure that you carefully read, understand and comply with the following danger warnings:







- Injuries and health hazards
- Damage to the product
- Product malfunction.

Hazard levels

| Hazard level | Indication |
|---|--|
|  DANGER: | It identifies a dangerous situation which, if not avoided, causes serious injury, or even death. |
|  WARNING: | It identifies a dangerous situation which, if not avoided, may cause serious injury, or even death. |
|  CAUTION: | It identifies a dangerous situation which, if not avoided, may cause small or medium level injuries. |
| NOTE: | It identifies a situation which, if not avoided, may cause damage to property but not to people. |

Special symbols

Some hazard categories have specific symbols, as shown in the following table:

| Symbol | Description |
|---|---|
|  | Electrical hazard |
|  | Magnetic hazard |
|  | Hot surface hazard |
|  | Ionizing radiation hazard |
|  | Potentially explosive atmosphere hazard (ATEX EU Directive) |
|  | Cut and abrasion hazard |
|  | Crushing hazard (limbs) |

1.2.2 User safety

Strictly comply with current health and safety regulations.



WARNING:

This product must be used only by qualified users.

For the purposes of this manual, in addition to the provisions of any local regulations, qualified personnel means any individuals who, due to their experience or training, are capable of recognising any existing hazards and to avoiding dangers during the installation, the use and the maintenance of the product.

Inexperienced users



WARNING:**FOR THE EUROPEAN UNION**

- This appliance can be used by children aged from 8 years and above and persons with reduced physical, sensory or mental capabilities or lack of experience and knowledge if they have been given supervision or instruction concerning use of the appliance in a safe way and understand the hazards involved.
- Children shall not play with the appliance.
- Cleaning and user maintenance shall not be made by children without supervision.

FOR OTHER COUNTRIES

- This appliance is not intended for use by persons (including children) with reduced physical, sensory or mental capabilities, or lack of experience and knowledge, unless they have been given supervision or instruction concerning use of the appliance by a person responsible for their safety.
 - Children should be supervised to ensure that they do not play with the appliance.
-

1.2.3 General safety rules



WARNING:

- Always keep the work area clean
 - Pay attention to the risks presented by gas and vapors in the work area
 - Always bear in mind the risk of drowning, electrical accidents, and burn injuries.
-



DANGER: Electrical hazard

- Avoid all electric dangers; pay attention to the risk of electric shock or electric arcs
 - Unintended rotation of motors creates voltage and can charge the unit, resulting in death, serious injury, or equipment damage. Ensure that motors are blocked to prevent unintended rotation.
-

Magnetic fields

The removal or installation of the rotor in the motor casing generates a strong magnetic field.



DANGER: Magnetic hazard

The magnetic field may be dangerous for anyone wearing pacemakers, or any other medical devices sensitive to magnetic fields.

NOTE

The magnetic field may attract metal debris on the rotor surface, causing damage to the same.

Electrical Connections



DANGER: Electrical hazard

- The connection to the electric power supply must be completed by an electrician possessing the technical-professional requirements outlined in the current regulations
-

Precautions before work



WARNING:

- Install a suitable barrier around the working area, for example a guard rail
 - Make sure that all safety guards are in place and secure
 - Make sure that you have a clear path of retreat
 - Make sure that the product cannot roll or fall over and injure people or damage property
 - Make sure that the lifting equipment is in good condition
 - Use a lifting harness, a safety line, and a breathing device as required
-

- Allow all pump system components to cool before handling them
- Make sure that the product has been thoroughly cleaned
- Disconnect and lock out power before you service the pump
- Check the explosion risk before you weld or use electric hand tools.

Precautions during work



WARNING:

- Never work alone
- Always wear personal protective equipment
- Always use suitable working tools
- Always lift the product by its lifting device
- Stay clear of suspended loads
- Beware of the risk of a sudden start if the product is used with an automatic level control
- Beware of the starting jerk, which can be powerful
- Rinse the components in water after you disassemble the pump
- Do not exceed the maximum working pressure of the pump
- Do not open any vent or drain valve or remove any plugs while the system is pressurized
- Make sure that the pump is isolated from the system and that all pressure is released before disassembling the pump, removing plugs, or disconnecting the piping
- Never operate the pump without a properly installed coupling guard.

In case of contact with chemical substances or dangerous liquids

Follow these procedures for chemicals or hazardous fluids that have come into contact with your eyes or your skin:

| Condition | Action |
|---------------------------------------|--|
| Chemicals or hazardous fluids in eyes | <ol style="list-style-type: none"> 1. Hold your eyelids apart forcibly with your fingers. 2. Rinse the eyes with eyewash or running water for at least 15 min. 3. Seek medical attention. |
| Chemicals or hazardous fluids on skin | <ol style="list-style-type: none"> 1. Remove contaminated clothing. 2. Wash the skin with soap and water for at least 1 min. 3. Seek medical attention, if necessary. |

1.2.4 Protection of the environment

Disposal of packaging and product

Comply with the current regulations on sorted waste disposal.

1.2.5 Sites exposed to ionizing radiations



WARNING: Ionizing radiation hazard

If the product has been exposed to ionizing radiations, implement the necessary safety measures for the protection of people. If the product needs to be despatched, inform the carrier and the recipient accordingly, so that appropriate safety measures can be put in place.

1.3 Spare parts

Identify the spare parts with the product codes directly on the site www.lowara.com/spark. Contact Xylem or the Authorised Distributor for technical information.

1.4 Product warranty

For information on the warranty refer to the documentation of the sale contract.

2 Handling and Storage

Packaging inspection

1. Check that quantity, descriptions and product codes match the order.
 2. Check the packaging for any damage or missing components.
 3. In case of immediately detectable damage or missing parts:
 - Accept the goods with reserve, indicating any findings on the transport document, or
 - Reject the goods, indicating the reason on the transport document.
- In both cases, promptly contact Xylem or the Authorised Distributor from whom the product was purchased.

Unpacking and inspection of the unit

1. Remove the packaging material from the product.
2. Release the product by removing the screws and/or cutting the straps, if fitted.



CAUTION: Cut and abrasion hazard

Always wear personal protective equipment.

3. Check the product for integrity and to make sure that there are no missing components.
4. In case of damage or missing components, promptly contact Xylem or the Authorised Distributor.

2.1 Unit handling

The unit must be hooked and lifted as shown in the figure.



WARNING: Crushing hazard (limbs)

- The product and its components may be heavy: risk of crushing
 - Always wear personal protective equipment
 - Manual handling of the product and its components must be in compliance with the current regulations on "manual load handling", to avoid unfavourable ergonomic conditions causing risks of back-spine injury.
 - Use cranes, ropes, lifting straps, hooks and clasps that comply with current regulations and that are suitable for the specific use
 - Make sure that the harnessing does not damage the unit
 - During the lifting operations, always avoid sudden movements that could compromise the stability of the load
 - During handling, make sure to avoid injury to people and animals, and/or damage to property.
-

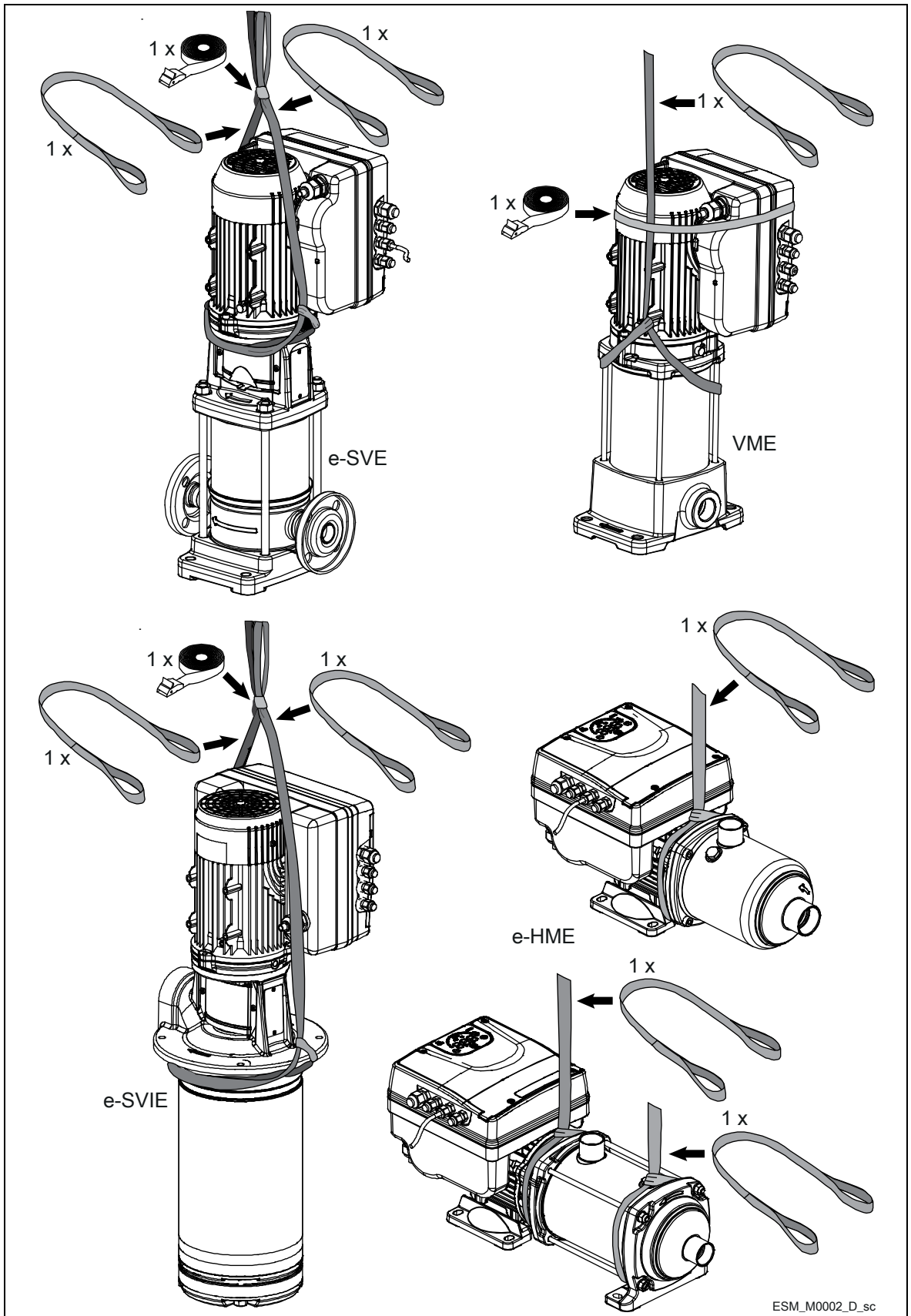

2.2 Storage

The product must be stored:

- In a covered and dry place
- Away from heat sources
- Protected from dirt
- Protected from vibrations
- At an ambient temperature between -25°C and +65°C (-13°F and 149°F), and relative humidity between 5% and 95%.



NOTE:

- Do not place heavy loads on top of the product
 - Protect the product from collisions.
-

3 Technical Description

3.1 Designation

Variable speed pump unit, vertical/horizontal, multi-stage, non self-priming.

3.2 Data plates

The data plate is a label showing:

- The main product details
- The identification code

Approval and certifications

For the approvals see the motor data plate:

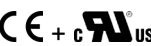
-  only
- 

3.2.1 Motor

Data plate

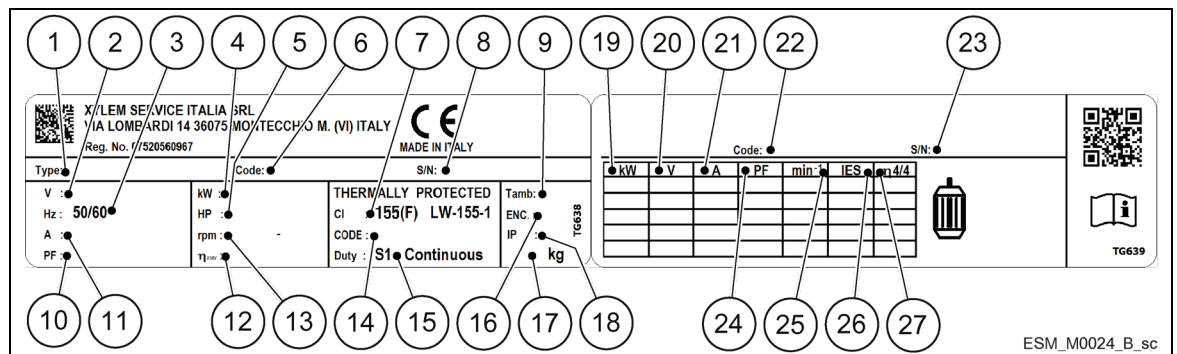

- | | |
|----------------------------------|--|
| 1. Type definition code | 15. Duty type |
| 2. Voltage rating | 16. Enclosure type (NEMA) |
| 3. Rated frequency | 17. Weight |
| 4. Rated power [kW] | 18. Protection class |
| 5. Rated power [HP] | 19. Shaft power |
| 6. Part number | 20. Voltage |
| 7. Insulation class | 21. Current |
| 8. Serial number | 22. Part number |
| 9. Maximum ambient temperature | 23. Serial number |
| 10. Power factor | 24. Power factor |
| 11. Current rating | 25. Rotation speed |
| 12. Motor drive efficiency | 26. Power drive system efficiency class (according to EN 50598-2) |
| 13. Full power speed range | 27. Full load efficiency |
| 14. Code letter for locked rotor | |

Identification code

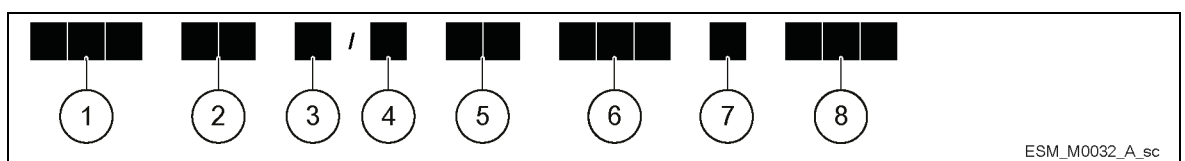

- 1. Series ESM
- 2. Motor frame dimension 90R: Oversized Flange
80: Standard Flange
- 3. Shaft extension □□: Standard shaft extension
S8: Custom Shaft extension
- 4. Power supply 1: single phase power supply
3: three phase power supply
- 5. Shaft power•10 [kW] 03: 0.37kW (0.50HP)
05: 0.55 kW (0.75 HP)
07: 0.75 kW (1.00 HP)
11: 1.10 kW (1.50 HP)
15: 1.50 kW (2.00 HP)
22: 2.20 kW (3.00 HP)
- 6. Motor frame arrangement SVE: Flange with tapped holes and shaft w/o keyseat
B14: Flange with tapped holes
B5: Flange with free holes
HMHA: Suitable for 1÷5 e-HME monolithic pumps
HMHB: Suitable for 1÷5 e-HME pumps w/sleeve
HMVB: Suitable for 1÷5 VM pumps
HMHC: Suitable for 10÷22 e-HME pumps
HMVC: Suitable for 10÷22 VM pumps
LNEE: Suitable for In-Line pumps
56J: Compliant to NEMA 56 Jet standard
56C: Compliant to NEMA 56C standard
- 7. Reference market □□: Standard
EU: EMEA
US: North America
- 8. Voltage 208-240 : 208-240VAC 50/60Hz
380-460 : 380-460VAC 50/60Hz
230/400: 208-240/380-460VAC 50/60Hz

3.2.2 e-HME and VME pumps

Data plate

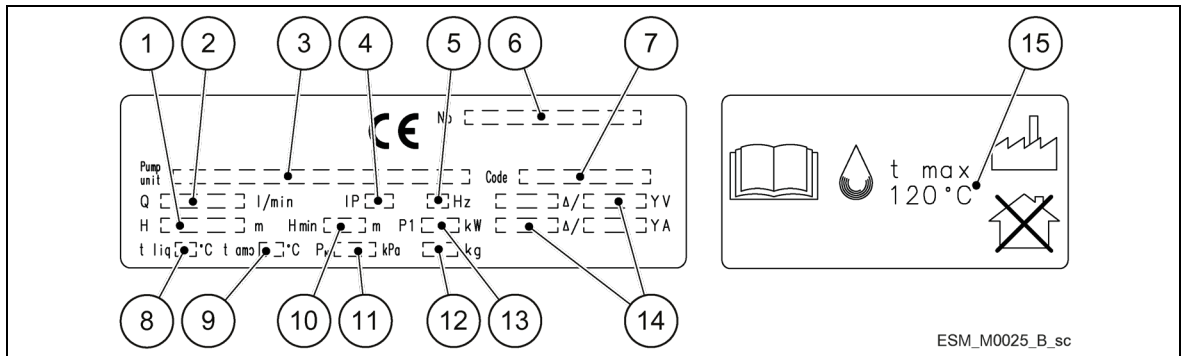

- 1. Head range
- 2. Flow rate range
- 3. Pump/electric pump unit type definition code
- 4. Protection class
- 5. Frequency
- 6. Serial number (date+progressive number)
- 7. Electric pump unit/pump part number
- 8. Maximum operating liquid temperature (uses as EN 60335-2-41)
- 9. Maximum operating ambient temperature
- 10. Minimum head (EN 60335-2-41)
- 11. Maximum operating pressure
- 12. Electric pump unit weight
- 13. Electric pump unit absorbed power
- 14. Electrical data
- 15. Maximum operating liquid temperature (uses other than as EN 60335-2-41)

e-HME type definition code

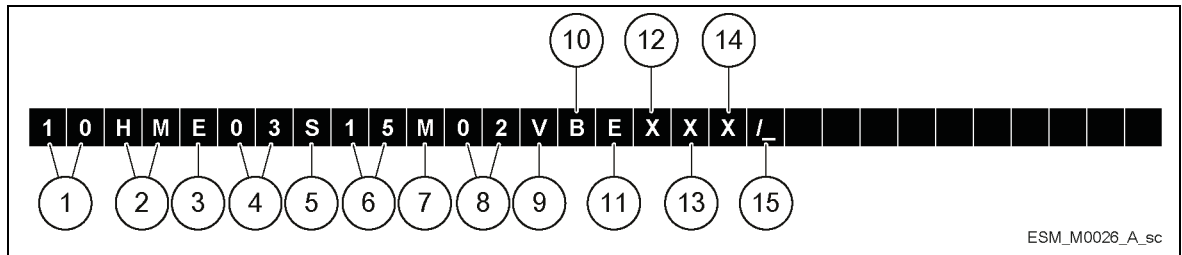

ESM_M0026_A_sc

- | | |
|-----------------------------|---|
| 1. Rated flow rate | [10] = m ³ /h |
| 2. Series name | [HM] |
| 3. Motor operation | [E] = e-SM |
| 4. Number of impeller | [03] = 3 impellers |
| 5. Material pump | [S] = Stainless steel (AISI 304) |
| 6. Motor rated power | kW x 10 |
| 7. Phase | [M] = Single-phase [T] = Three-phase |
| 8. Power Supply Voltage | e-SM Power supply 02 = 1x208-240 V 04 = 3x380-460 V 05 = 3x208-240/380-460 V |
| 9. Rotating part | [Q] = Silicon Carbide (Q ₁) [V] = Aluminium oxide (Ceramic) |
| 10. Stationary part | [Q] = Silicon Carbide (Q ₁) [B] = Carbon resin impregnated |
| 11. Elastomers | [E] = EPDM [V] = FPM [K] = FFPM (Kairez®) |
| 12. General characteristics | Null = None Z = other |
| 13. General characteristics | Null = None |
| 14. Connections | Null = Threaded |
| 15. | Null or letter assigned by the manufacturer |

VME type definition code

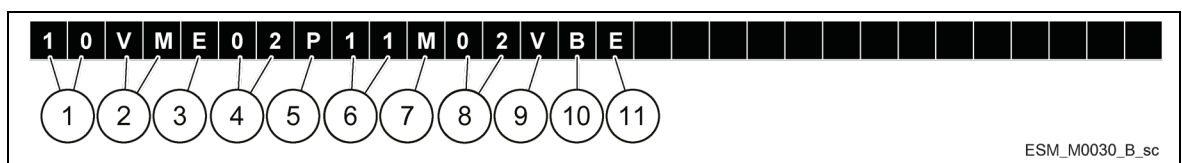

ESM_M0030_B_sc

- | | |
|-------------------------|---|
| 1. Rated flow rate | [10] = m ³ /h |
| 2. Series name | [VM] |
| 3. Motor operation | [E] = e-SM |
| 4. Number of impeller | [02] = 2 impellers |
| 5. Material pump | [P] = Stainless steel AISI 304 with Noryl™ impellers |
| 6. Motor rated power | kW x 10 |
| 7. Phase | [M] = Single-phase pump unit [T] = Three-phase pump unit |
| 8. Power Supply Voltage | [2] = 1x208-240 V [4] = 3x380-460 V [5] = 3x208-240/380-460 V |
| 9. Rotating part | [V] = Aluminium oxide (Ceramic) |
| 10. Stationary parts | Carbon resin impregnated |
| 11. Elastomers | [E] = EPDM |

3.2.3 e-SVE pump

Data plate

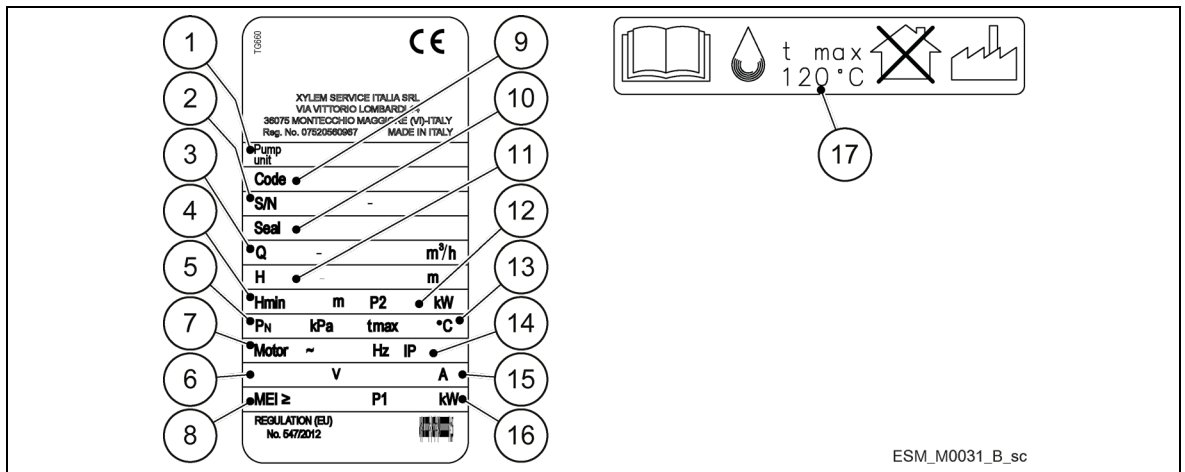

- | | |
|--|---|
| 1. Pump / electric pump unit type | 10. Mechanical seal material identification code |
| 2. Serial number (date+progressive number) | 11. Head range |
| 3. Flow rate range | 12. Motor rated power |
| 4. Minimum head (EN 60335-2-41) | 13. Maximum operating liquid temperature (uses as EN 60335-2-41) |
| 5. Maximum operating pressure | 14. Protection class |
| 6. Rated voltage range | 15. Current |
| 7. Frequency | 16. Electric pump unit absorbed power |
| 8. Minimum efficiency index | 17. Maximum operating liquid temperature (uses other than as EN 60335-2-41) |
| 9. Electric pump unit/ pump part number | |

Identification code

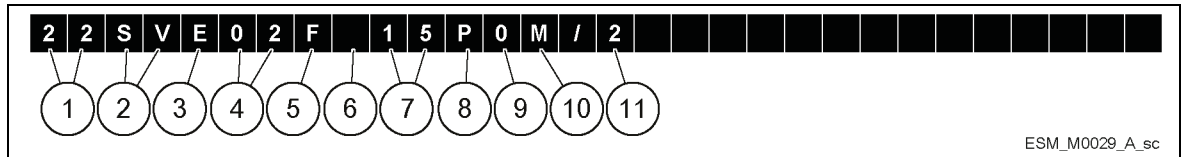

- | | |
|--------------------------|---|
| 1. Rated flow rate | [22] = m ³ /h |
| 2. Series name | [SV] |
| 3. Motor operation | [E] = e-SM |
| 4. Number of impeller | [02] = 2 impellers |
| 5. Material pump | [F] = Stainless steel AISI 304, round flanges (PN 25) [T] = Stainless steel AISI 304, oval flanges (PN 16) [R] = Stainless steel AISI 304, discharge port above suction, round flanges (PN 25) [N] = Stainless steel AISI 316, round flanges (PN 25) |
| 6. Version | Empty = standard version |
| 7. Motor rated power | kW x 10 |
| 8. Number of poles | [P] = e-SM |
| 9. Frequency | [0] = e-SM |
| 10. Phase | Null = pump [M] = Single-phase pump unit [T] = Three-phase pump unit |
| 11. Power Supply Voltage | [2] = 1x208-240 V [4] = 3x380-460 V [5] = 3x208-240/380-460 V |

3.2.4 e-SVIE pump

Data plate of models 1, 3, 5SVI (E) - 1~

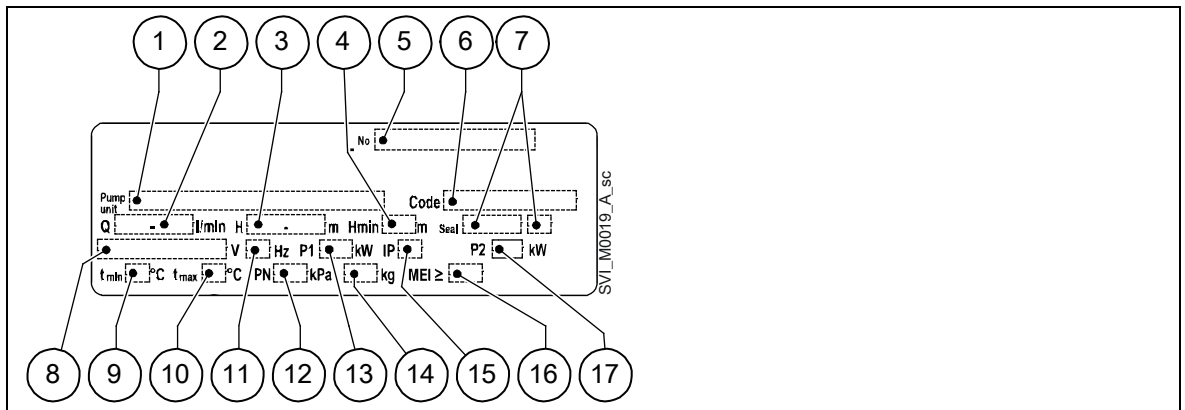

- | | |
|--|--|
| 1. Pump or pump unit type | 9. Minimum liquid operating temperature |
| 2. Flow rate range | 10. Maximum liquid operating temperature |
| 3. Head range | 11. Frequency |
| 4. Minimum head | 12. Maximum operating pressure |
| 5. Serial number + manufacturing date | 13. Pump rated power |
| 6. Product code | 14. Weight |
| 7. Mechanical seal and O-ring materials identification codes | 15. Protection class |
| 8. Rated voltage range | 16. Minimum efficiency index |
| | 17. Electric pump unit absorbed power |

Data plate of models 1, 3, 5SVI (E) - 3~ / 1, 3, 5, 10, 15, 22SVI (C, M)

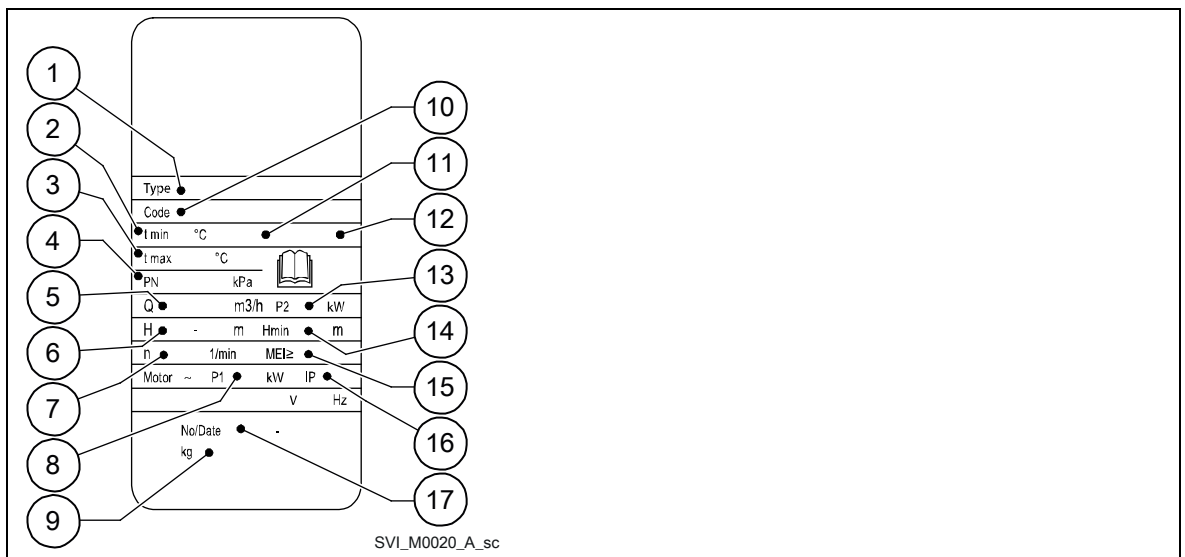

- | | |
|---|---|
| 1. Pump or pump unit type | 10. Product code |
| 2. Minimum liquid operating temperature | 11. Mechanical seal materials identification code |
| 3. Maximum liquid operating temperature | 12. O-ring materials identification code |
| 4. Maximum operating pressure | 13. Electric pump unit absorbed power |
| 5. Flow rate range | 14. Minimum head |
| 6. Head range | 15. Minimum efficiency index |
| 7. Rotation speed | 16. Protection class |
| 8. Pump rated power | 17. Serial number + manufacturing date |
| 9. Weight | |

Data plate of models 33, 46, 55, 92 (S, N)

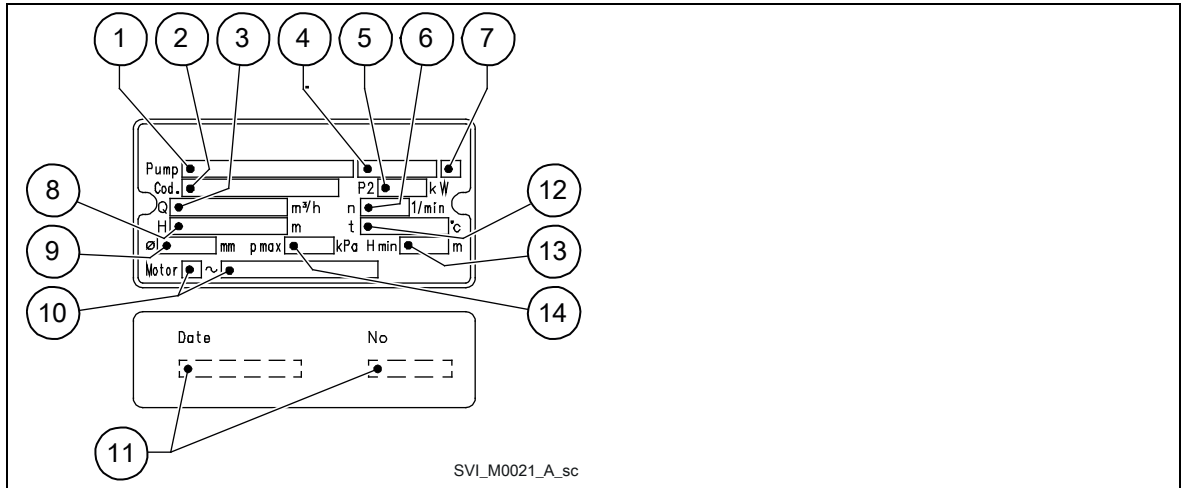

- | | |
|--|--|
| 1. Pump unit type | 8. Head range |
| 2. Product code | 9. - |
| 3. Flow rate range | 10. Type of motor |
| 4. Mechanical seal materials identification code | 11. Manufacturing date + serial number |
| 5. Electric pump unit absorbed power | 12. Maximum liquid operating temperature |
| 6. Rotation speed | 13. Minimum head |
| 7. O-ring materials identification code | 14. Maximum operating pressure |

Identification code for models 1, 3, 5, 10, 15 and 22

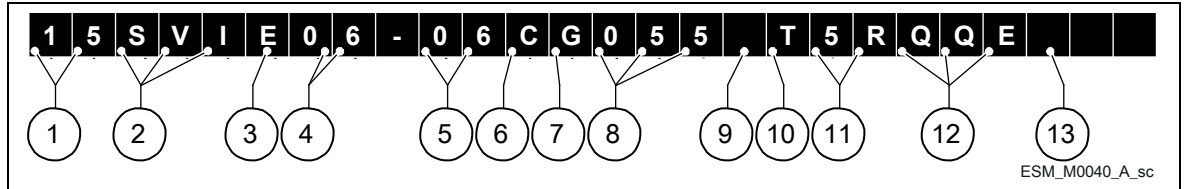

1. Flow rate in m³/h
2. Series name
3. Standard asynchronous motor with e-SM Drive [E]
4. Number of impeller
5. Number of stages
6. Version with extended shaft [E], with cartridge seal [C], standard [M] or special [X] seal
7. Material: AISI 304 [G] or AISI 316 [N]
8. Rated motor power in kWx10
9. 2-pole [2], 4-pole [4] or e-SM Drive [P] motor
10. Single-phase motor [M], three-phase motor [T] or bare shaft pump []
11. Power supply voltage with e-SM Drive: 1x208-240 V [02], 3x380-460 V [04] or 3x208-240/380-460 V [05]
12. Mechanical seal and elastomers
13. Other information: standard [], PTC [P], motor heater [S], UL approved (cURus) [U], other specifications [Z]

Identification code for models 33, 46, 66 and 92

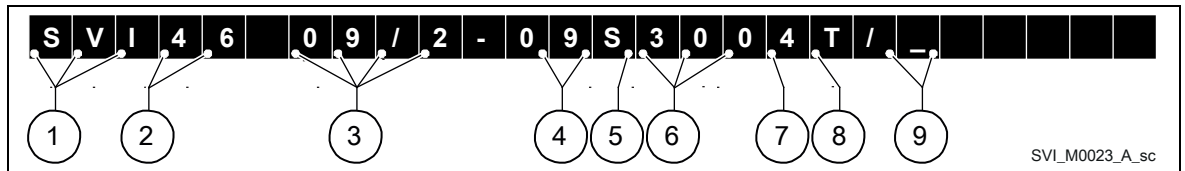

1. Series name
2. Flow rate in m3/h
3. Number of impeller
4. Number of stages
5. Version with coupling [S] or AISI 316 with coupling [N]
6. Rated motor power in kWx10
7. 2-pole [] or 4-pole [4] motor
8. Single-phase motor [M], three-phase motor [T] or bare shaft pump []
9. Other information

3.3 Design and layout

The unit can be fitted with the features the application requires.

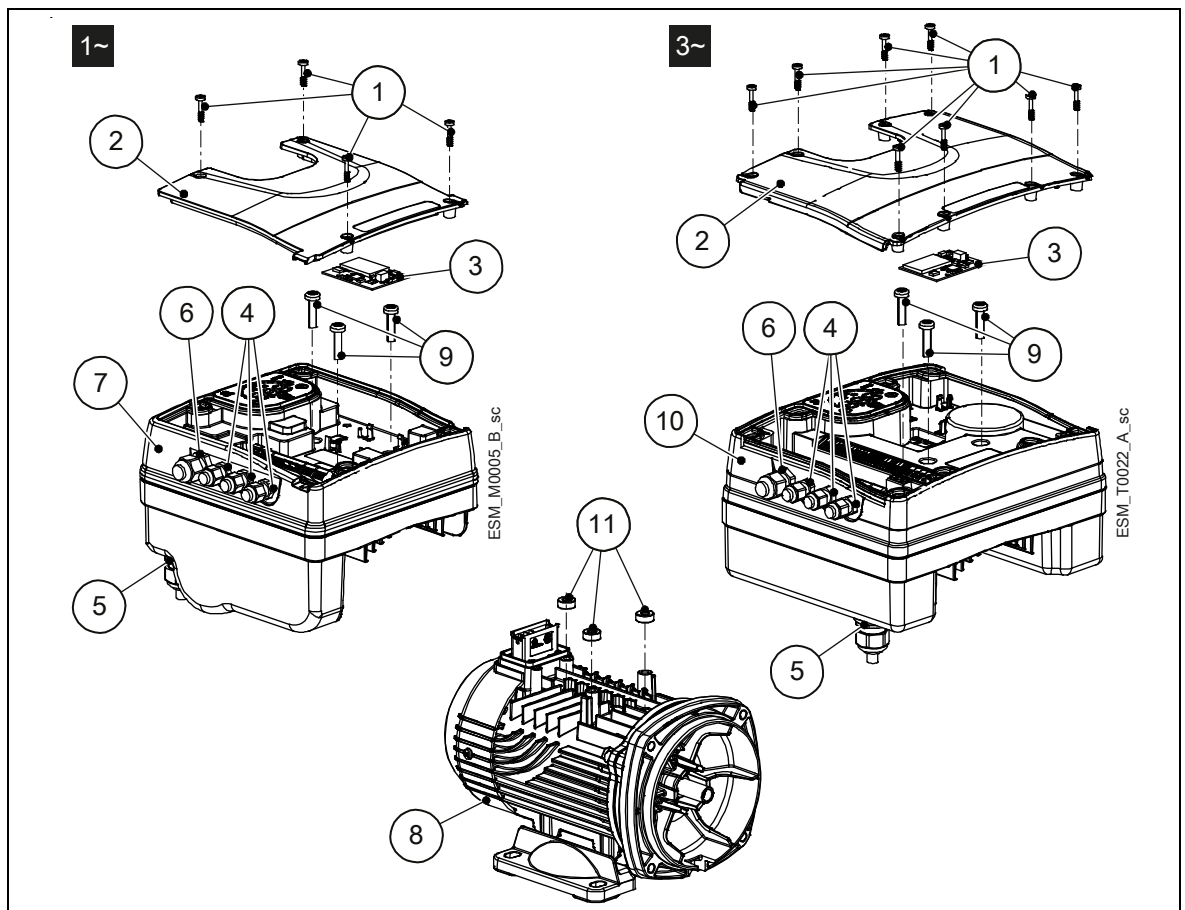

| Position number | Description | Tightening torque $\pm 15\%$ | |
|-----------------|---|------------------------------|----------|
| | | [Nm] | [in•lbs] |
| 1 | Screw | 1.4 | 12.4 |
| 2 | Terminal Box Cover | - | - |
| 3 | Optional module with strip | - | - |
| 4 | M12 I/O cable gland | 2.0 | 17.7 |
| 5 | M20 cable gland for power supply cables | 2.7 | 23.9 |
| 6 | M16 I/O cable gland | 2.8 | 24.8 |
| 7 | Drive (single-phase model) | - | - |
| 8 | Motor | - | - |
| 9 | Screw | 6.0 | 53.1 |
| 10 | Drive (three-phase model) | - | - |
| 11 | Spacer | - | - |

Pre-assembled ex factory components

| Component | Quantity | Notes |
|--------------------------|----------|---------------------------------|
| Plug for Cable Gland | M12 | 3 |
| | M16 | 1 |
| | M20 | 1 |
| Cable gland and lock nut | M12 | 3 |
| | M16 | 1 |
| Cable Gland | M20 | 1 |
| | | Cable Outer Diameter: |
| | | 3.7 to 7.0 mm (0.145÷0.275 in) |
| | | 4.5 to 10.0 mm (0.177÷0.394 in) |
| | | 7.0 to 13.0 mm (0.275÷0.512 in) |

Optional components

| Component | Description |
|--------------|---|
| Sensors | The following sensors can be used with the unit: <ul style="list-style-type: none"> Level-sensor |
| RS485 Module | For the connection of a multi-pump system to a supervision system, via cable (Modbus or BACnet MS/TP protocol) |
| Adaptor | M20 Metric to 1/2" NPT Adapter (item is always supplied for US market) |

3.4 Intended use

The product can be used to pump:

- Cold water
- Hot water

Refer to the standard Installation, Operation and Maintenance Manual for pump design specification.

The variable speed pump units are made for the following applications:

- Pressure, level, and flow regulation (open loop systems)
- Single or multi pump irrigation systems.

3.4.1 Application alternatives

Actuator (constant speed)

The unit operates as an actuator according to speed set point; this is done through user interface, the corresponding analog input or the communication bus.

Controller (constant pressure)

This mode is set as the default operating mode, and is used for single pump operating units.

Cascade serial / Cascade synchronous

The units are connected via the RS485 interface and communicate via the provided protocol. The combination of the different units which are used in a multi-pump system depends on the system requirements.

It is possible to run all pumps in cascade serial mode and cascade synchronous mode as well. If one unit fails, then each pump of the system can become the lead pump and can take control.

3.5 Improper use



WARNING:

Improper product use can create dangerous conditions and cause personal injuries and damage to property

Also refer to the “Quick Startup Guide” and the “Installation, Operation and Maintenance Manual” of the e-SVE, VME, e-HME and e-SVIE pumps supplied with the product.

4 Installation

4.1 Mechanical installation

Also refer to the “Quick Startup Guide” and the “Installation, Operation and Maintenance Manual” of the e-SVE, VME, e-HME and e-SVIE pumps supplied with the product.

4.1.1 Installation area



DANGER: Potentially explosive atmosphere hazard

The operation of the unit in environments with potentially explosive atmospheres or with combustible dusts (e.g.: wood dust, flour, sugars and grains) is strictly forbidden.



WARNING:

- Always wear personal protective equipment
 - Always use suitable working tools
 - When selecting the place of installation and connecting the unit to the hydraulic and electric power supplies, strictly comply with current regulations.
 - Ensure that the input protection rating of the unit (IP 55, NEMA Type 1) is suitable for the installation environment.
-



CAUTION:

- Input protection: to ensure the IP55 (NEMA type 1) protection index make sure that the unit is closed correctly.
 - Before opening the terminal box cover, make sure that there is no water in the unit
 - Make sure that all unused cable glands and cable holes are correctly sealed
 - Make sure that the plastic cover is correctly closed
 - Do not leave the terminal box without cover: risk of damage due to contamination.
-

4.1.2 Unit installation

- See the Quick Startup Guide instructions (code 001080128)
- Position the unit as shown in the figure.
- Install the unit according to the systems liquid flow
- The arrows on the pump body indicate the flow and the rotation direction
- The standard rotation direction is clockwise (looking at the fan cover)
- Always install a check valve on the discharge side
- Always install the pressure sensor on the discharge side, after the check valve.

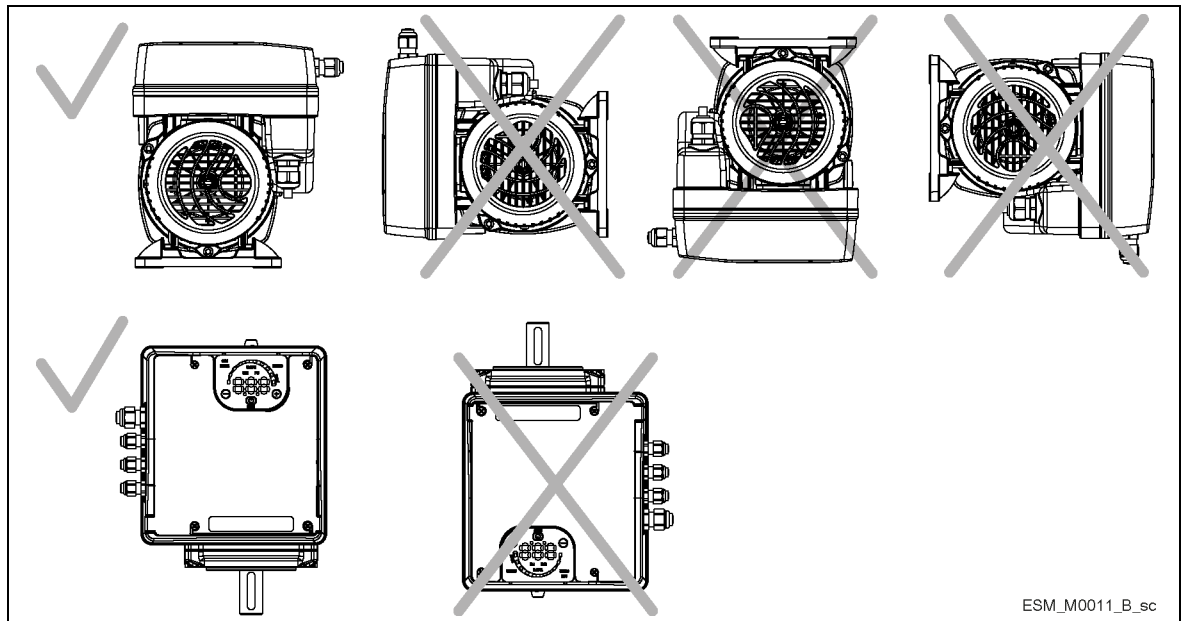

4.1.3 Outdoor unit installation

In case of outdoor unit installation, ensure appropriate cover, see the figure below. The size of the cover must be such that the motor is not exposed to snow, rain or direct sunlight; see also Technical Information on page 48.

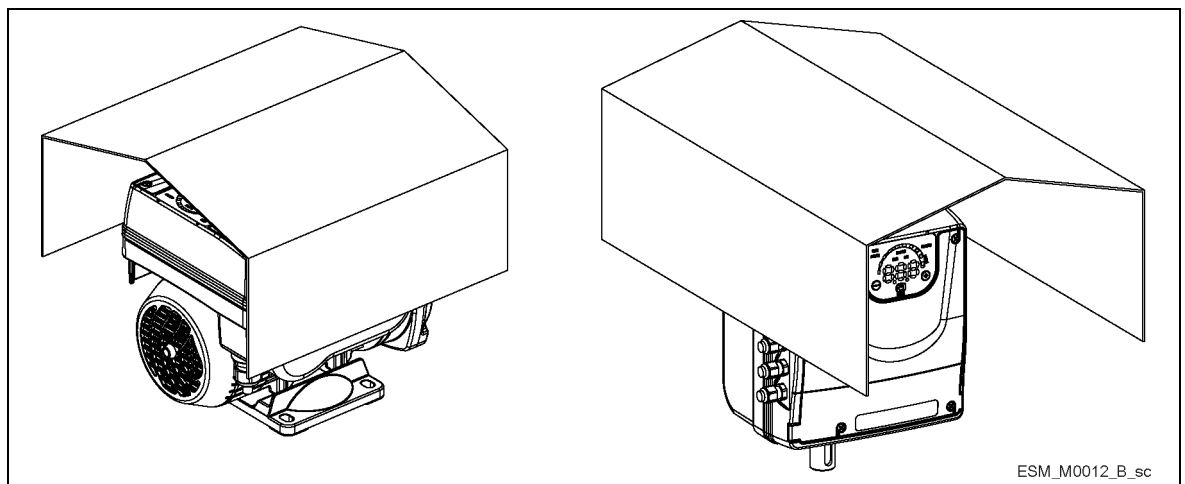

Minimum spacing

| Area | e-SM Drive model | Free Distance |
|---|------------------------------|-------------------|
| Above the unit | 103..105..107..111..115 | > 260mm (10.2 in) |
| Center-distance between units (to ensure space for cabling) | 103..105..107..111..115 | > 260mm (10.2 in) |
| | 303..305..307..311..315..322 | ≥ 300mm (11.8 in) |

4.2 Hydraulic installation

A system with single pump and a multi-pump system are shown in the figures.

NOTE:

If the system is directly connected to the water network, install a minimum pressure switch on the suction side.

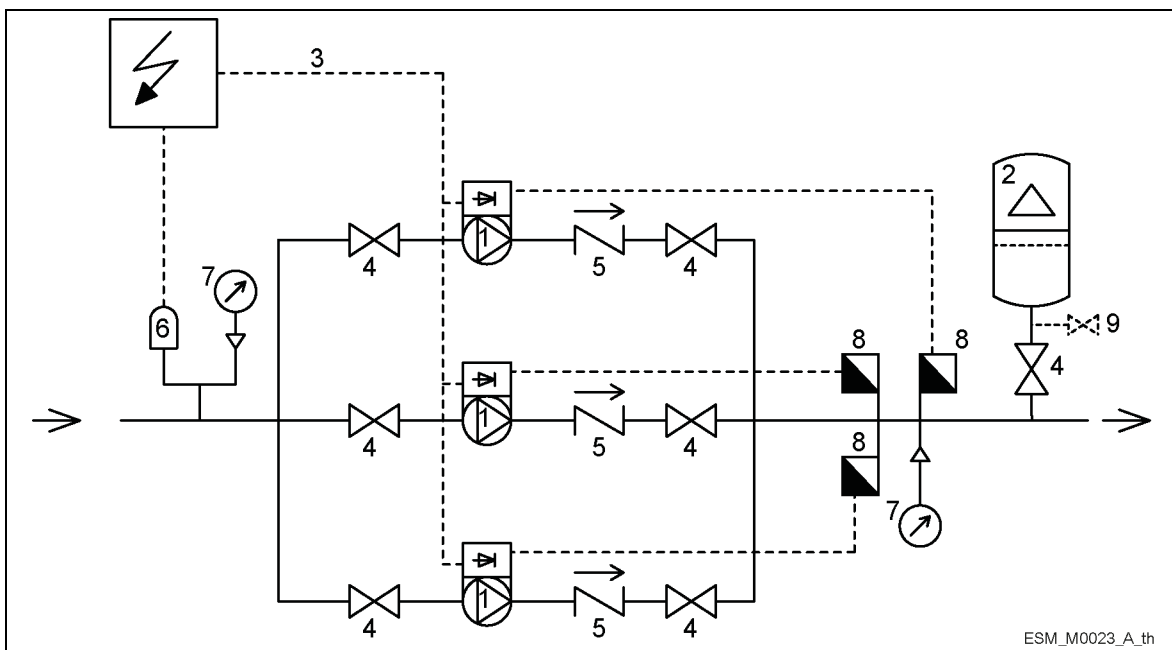
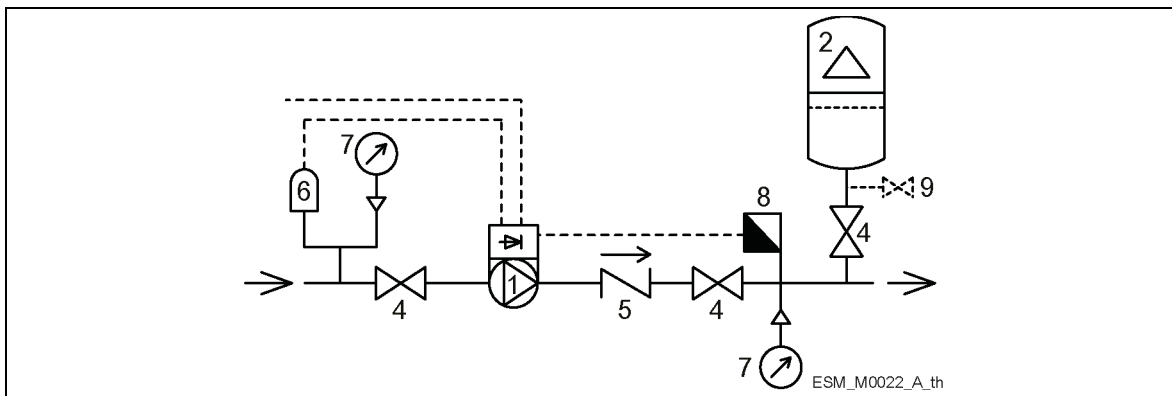

- | | | |
|-------------------------------|----------------------|--------------------|
| 1. Pump with e-SM Motor Drive | 4. On-off valve | 7. Pressure gauge |
| 2. Diaphragm pressure tank | 5. Check valve | 8. Pressure sensor |
| 3. Control panel | 6. Low water control | 9. Drain tap |

Diaphragm pressure tank

On the pump delivery side there is a membrane expansion vessel, which gives the possibility of maintaining the pressure inside the piping when the system is not being used. The unit stops the pump from continuing to run at zero demand and reduce the size of the tank that is required for supply purposes.

Select a vessel suitable for the system pressure, and pre-load it in accordance with the values indicated in the Quick Startup Guide (code 001080128).

4.3 Electrical Installation



DANGER: Electrical hazard



The connection to the electric power supply must be completed by an electrician possessing the technical-professional requirements outlined in the current regulations.

4.3.1 Electrical requirements

Local directives prevail on the specific requirements indicated below.

Electrical connection check list

Check that the following requirements are met:

- The electrical leads are protected from high temperature, vibrations, and collisions
- The main power supply current and voltage must meet the specifications on the data plate on the unit
- The power supply line is provided with:
 - A mains isolator switch with a contact gap of at least 3 mm.
- Ground fault circuit breaker (GFCI), or residual current devices (RCD), also known as automatic earth leakage circuit breakers (ELCD); comply with the following:
 - For single-phase power supply versions use GFCI (RCD), which are capable of detecting alternate currents (AC) and pulsing currents with DC components. These GFCI (RCD) are marked with the following symbol 
 - For three-phase power supply versions use GFCI (RCD), which are capable of detecting AC and DC currents. These GFCI (RCD) are marked with the following symbols 
 - Use GFCI (RCD) with a starting delay, to avoid problems due to transient earth currents.
 - The size of the GFCI (RCD) must comply with the system configuration and the environmental conditions.

NOTE:

When selecting an automatic earth leakage circuit breaker or a ground fault circuit breaker, make sure to consider the total earth leakage current of all the electric devices of the system.

The electrical control panel checklist

NOTE:

The control panel must match the ratings of the pump unit. Inappropriate combinations do not guarantee the protection of the unit.

Check that the following requirements are met:

- The control panel must protect the pump against short-circuit. A time lag fuse or a C type circuit breaker (MCB) can be used to protect the pump.
- The pump is fitted with thermal and overload protection.



DANGER: Electrical hazard

- Before completing any electrical connections, make sure that the unit and the electric panel are isolated from the power supply and cannot be energized.
- Contact with electric components may cause death, even after the unit has been switched off.
- Before any interventions on the unit, the network voltage and any other input voltages must be disconnected for the minimum time indicated in Wait times on page 29.

Grounding (earthing)



DANGER: Electrical hazard

- Always connect the external protection conductor to the ground terminal before attempting to make any other electrical connections
- Connect all the electric accessories of the pump and the motor to the ground, making sure that the connections are completed correctly
- Check that the protection conductor (ground) is longer than the phase conductors; in case of accidental disconnection of the power supply conductor, the protection conductor (ground) must be the last one to detach itself from the terminal.

Use a cable with several strands to reduce electric noise.

4.3.2 Wire types and ratings

- All cables must comply with local and national standards in terms of section and ambient temperature
- Use cables with minimum heat resistance +70°C (158°F); to ensure compliance with UL (Underwriters Laboratories) regulations, all power supply connections must be completed using the following types of copper cables with minimum resistance +75°C: THW, THWN
- Cables must never enter into contact with the motor body, the pump and the piping.
- The wires connected to the power supply terminals and the fault signal relay (NO, C) must be separated from the others by means of reinforced insulation.

| e-SM Drive models | Power supply input cable + PE | | Tightening torque | |
|------------------------------|---|-------------------------|---------------------------------|--------------------|
| | Wire numbers x Max. copper section | Wire numbers x Max. AWG | Mains and motor cable terminals | Earth Conductor |
| 103, 105, 107, 111, 115 | 3 x 1.5 mm ² 3 x 0.0023 sq.in | 3 x 15 AWG | Spring connectors | Spring connectors |
| 303, 305, 307, 311, 315, 322 | 4 x 1.5 mm ² 4 x 0.0023 sq.in | 4 x 15 AWG | 0.8 Nm 7.1 lb-in | 3 Nm 26.6 lb-in |

Control cables

External volt free contacts must be suitable for switching < 10 VDC.

NOTE:

- Install the control cables separate from the power supply cables and the fault signal relay cable
- If the control cables are installed in parallel with the power supply cable or the fault signal relay, the distance between the cables must exceed 200 mm
- Do not intersect the power supply cables; should this be necessary, a 90° intersection angle is permitted.

| e-SM Drive control cables | Wires number x Max. copper Section | AWG | Tightening torque |
|---------------------------|--|-----------|---------------------|
| All I/O conductors | 0.75÷1.5 mm ² 0.00012÷0.0023 sq.in | 18÷16 AWG | 0.6 Nm 5.4 lb-in |

4.3.3 Power supply connection



WARNING: Electrical hazard

Contact with electric components may cause death, even after the unit has been switched off. Before any interventions on the unit, the network voltage and any other input voltages must be disconnected for the minimum time indicated in paragraph Wait times on page 29.



WARNING:

Only connect the electronic drive to Safety Extra Low Voltage circuits (SELV = very low safety voltage). Circuits intended for use with external communication and control equipment are designed to ensure insulation from the dangerous adjoining circuits inside the unit. Communication and control circuits inside the unit are floating in relation to the mass and are classed as SELV. They must only be connected to other SELV circuits, in order to maintain all the circuits within the SELV limits and avoid mass loops. The physical and electric separation of the communication and control circuits from non-SELV electric circuits must be maintained both inside and outside the inverters.

Power supply wiring procedure

Also see Design and layout on page 17.

1. Open the terminal box cover, remove the screws.
2. Insert the power cable in the M20 cable gland.
3. Connect the cable according to the wiring diagram. See the figure below.
4. Connect the earth conductor (mass), making sure that it is longer than the phase conductors.
5. Connect the phase leads.
6. Close the cover and tighten the screws.

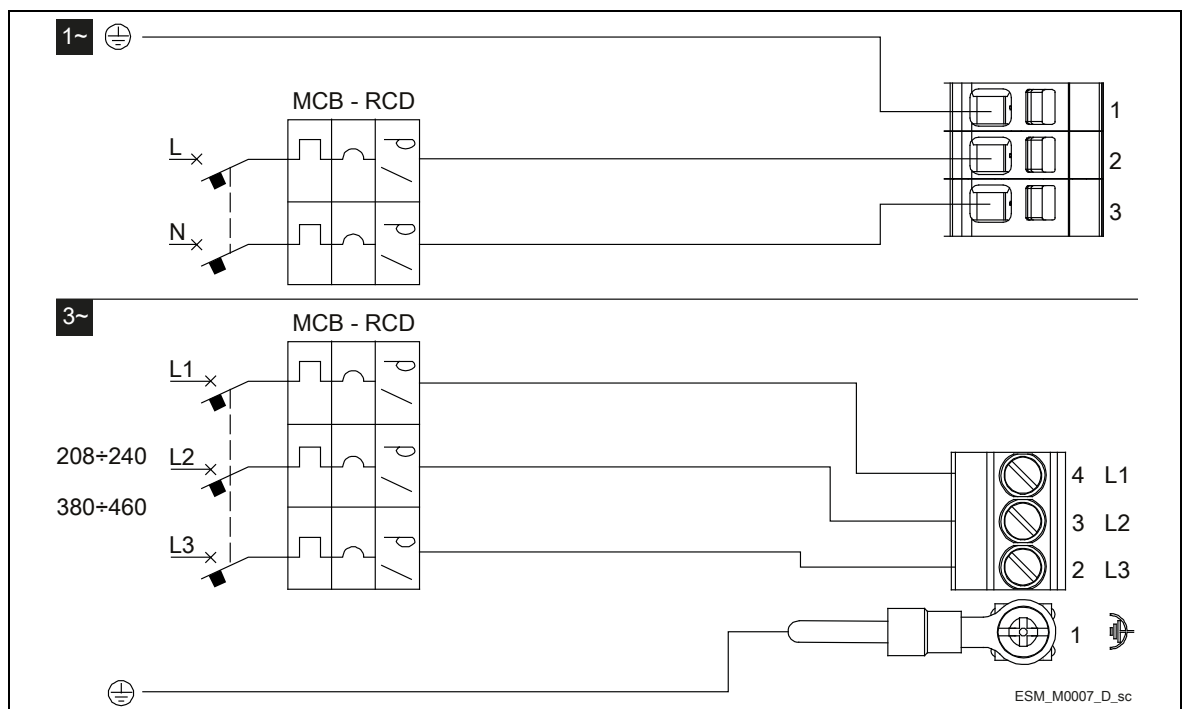

I/O wiring procedure

Also see Design and layout on page 17.

1. Open the terminal box cover, remove the screws.
2. Connect the cable according to the wiring diagram. See the figure below.
3. Close the cover and tighten the screws.

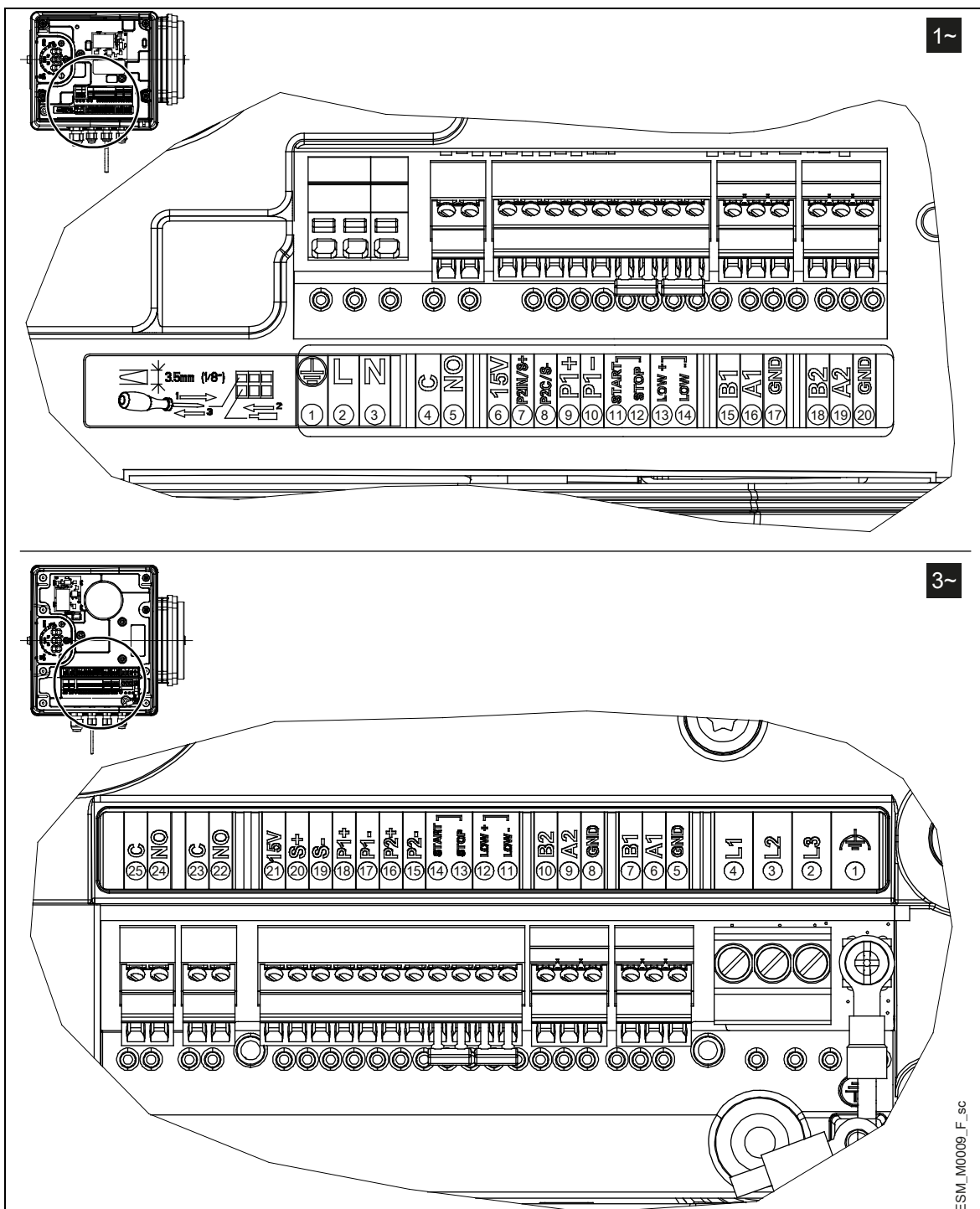

| | Item | Terminals | Ref. | Description | Notes | |
|--|--|--------------|------|---|---|--|
| 1~ | Fault signal | C | 4 | COM - error status relay | Closed: error | |
| | | NO | 5 | NO - error status relay | Open: no error or unit off | |
| | Auxiliary Voltage Supply | 15V | 6 | Auxiliary voltage supply +15 VDC | 15VDC, Σ max. 100 mA | |
| | Analog input 0-10V | P2IN/S+ | 7 | Actuator mode 0-10 V input | 0÷10 VDC | |
| | | P2C/S- | 8 | GND for 0-10 V input | GND, electronic ground (for S+) | |
| | External Pressure sensor [also Differential] | P1+ | 9 | Power supply external sensor +15 VDC | 15VDC, Σ max. 100 mA | |
| | | P1- | 10 | External sensor 4-20 mA input | 4÷20 mA | |
| | External Start/Stop | START | 11 | External ON/OFF input reference | Default short circuited. Pump is enabled to RUN | |
| | | STOP | 12 | External ON/OFF input | | |
| | External Lack of Water | LOW+ | 13 | Lack water input | Default short circuited. Lack of water detection: enabled | |
| | | LOW- | 14 | Low water reference | | |
| | Communication Bus | B1 | 15 | RS485 port 1: RS485-1N B (-) | ACT, HCS control mode: RS 485 port1 for external communication MSE, MSY control mode: RS 485 port 1 for multi-pump systems | |
| | | A1 | 16 | RS485 port 1: RS485-1P A (+) | | |
| | | GND | 17 | Electronic GND | | |
| | Communication Bus | B2 | 18 | RS485 port 2: RS485-2N B (-) active only with optional module | RS 485 port2 for external communication | |
| | | A2 | 19 | RS485 port 2: RS485-2P A (+) active only with optional module | | |
| | | GND | 20 | Electronic GND | | |
| | 3~ | Fault signal | C | 25 | COM - error status relay | Closed: error |
| | | | NO | 24 | NO - error status relay | Open: no error or unit off In case of power cables: use the M20 cable gland |
| Motor running signal | | C | 23 | Common contact | Closed: motor in operation | |
| | | NO | 22 | Normally open contact | Open: motor not in operation In case of power cables: use the M20 cable gland | |
| Auxiliary Voltage Supply | | 15V | 21 | Auxiliary voltage supply +15 VDC | 15VDC, Σ max. 100 mA | |
| Analog input 0-10V | | S+ | 20 | Actuator mode 0-10 V input | 0÷10 VDC | |
| | | S- | 19 | GND for 0-10 V input | GND, electronic ground (for S+) | |
| External Pressure sensor [also Differential] | | P1+ | 18 | Power supply external sensor +15 VDC | 15VDC, Σ max. 100 mA | |
| | | P1- | 17 | External sensor 4-20 mA input | 4÷20 mA | |
| External pressure sensor | | P2+ | 16 | Power supply external sensor +15 VDC | 15VDC, Σ max. 100 mA | |
| | | P2- | 15 | Sensor 4-20 mA input | 4÷20 mA | |
| External Start/Stop | | Start | 14 | External ON/OFF input | Default short circuited. Pump is enabled to RUN | |
| | | Stop | 13 | External ON/OFF input reference | | |
| External Lack of Water | | LoW+ | 12 | Lack water input | Default short circuited. Lack of water detection: enabled | |
| | | LoW- | 11 | Low water reference | | |
| Communication Bus | | B2 | 10 | RS485 port 2: RS485-2N B (-) active only with optional module | RS 485 port2 for external communication | |

| | | | | | |
|--|-------------------|-----|---|---|--|
| | | A2 | 9 | RS485 port 2: RS485-2P A (+) active only with optional module | |
| | | GND | 8 | Electronic GND | |
| | Communication Bus | B1 | 7 | RS485 port 1: RS485-1N B (-) | ACT, HCS control mode: RS 485 port 1 for external communication Control mode MSE, MSY: RS 485 port 1 for multi-pump systems |
| | | A1 | 6 | RS485 port 1: RS485-1P A (+) | |
| | | GND | 5 | Electronic GND | |

5 Operation

In case of co-existence of two or more of the following conditions:

- high ambient temperature
 - high water temperature
 - duty points insisting on unit maximum power
 - persisting undervoltage of mains,
- may jeopardise the life of the unit, and/or derating may occur: for further information contact Xylem or the Authorised Distributor.

5.1 Wait times



WARNING: Electrical hazard

Contact with electric components may cause death, even after the unit has been switched off. Before any interventions on the unit, the network voltage and any other input voltages must be disconnected for the minimum time indicated in the table.

| Mode (power supply) | Minimum waiting times (min) |
|---------------------|-----------------------------|
| Single-phase | 4 |
| Three-phase | 5 |



WARNING: Electrical hazard

Frequency converters contain DC-link capacitors that can remain charged even when the frequency converter is not powered.

To avoid electrical hazards:

- Disconnect the AC power supply
 - Disconnect all types of permanent magnet motors
 - Disconnect all DC-link remote power supplies, including the battery backups, the Uninterrupted Power Supply units and the DC-link connections to other frequency converters
 - Wait for the capacitors to discharge completely before carrying out any maintenance or repairs; see the table above for the waiting times
-

6 Programming

Precautions

NOTE:

- Carefully read and follow the following instructions before starting the programming activities, to avoid wrong settings that may cause malfunctioning
- All modifications must be done by qualified technicians.



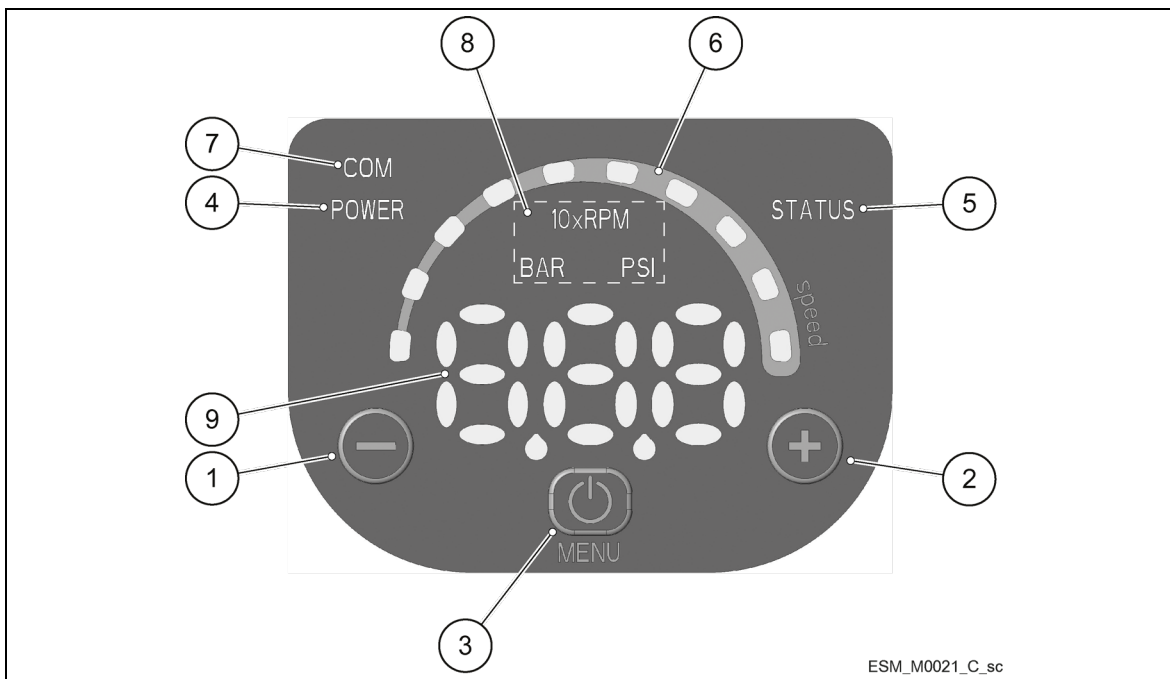





6.1 Control panel



ESM_M0021_C_sc

| Position number | Description | Para. |
|-----------------|-----------------------------------|-------|
| 1 | Decrease button | 6.2 |
| 2 | Increase button | 6.2 |
| 3 | START/STOP and menu access button | 6.2 |
| 4 | POWER LED | 6.3.1 |
| 5 | Status LED | 6.3.2 |
| 6 | Speed LED bar | 6.3.3 |
| 7 | Communication LED | 6.3.4 |
| 8 | Unit of measure LEDs | 6.3.5 |
| 9 | Display | 6.4 |

6.2 Description of the buttons

| Push button | Function |
|---|--|
|  | <ul style="list-style-type: none"> Main view (see Par. 6.4.1): decreases the required value for the selected control mode Parameter menu (see Par. 6.4.2): decreases the displayed parameter index Parameter view / editing (see Par. 6.4.2): decreases the value of the displayed parameter Zero pressure auto-calibration (see Par. 6.5, P44): automatic calibration of the pressure sensor. |
|  | <ul style="list-style-type: none"> Main view (see Par. 6.4.1): increases the required value for the selected control mode Parameter menu (see Par. 6.4.2): increases the displayed parameter index Parameter view / editing (see Par. 6.4.2): increases the value of the displayed parameter Zero pressure auto-calibration (see Par. 6.5, P44): automatic calibration of the pressure sensor. |
|  | <ul style="list-style-type: none"> Main view (see Par. 6.4.1): START/STOP the pump Parameter menu (see Par. 6.4.2): switches to parameter view / editing Parameter view / editing (see Par. 6.4.2): saves the value of the parameter. |
|  long press | <ul style="list-style-type: none"> Main view (see Par. 6.4.2): switches to parameter selection Parameters Menu: switches to Main Visualization |
|  and  | Main view: alternates between Speed and Head units of measure (see Par. 6.4.1). |
|  and  | Main view: alternates between Speed and Head units of measure (see Par. 6.4.1). |

6.3 LEDs description

6.3.1 POWER (power supply)

When ON (**POWER**) the pump is powered and the electronic devices are operational.

6.3.2 STATUS

| LED | Status |
|---------------------------|---|
| Off | Pump unit stopped |
| Green steady | Pump unit in operation |
| Flashing green and orange | Non-locking alarm with the pump unit in operation |
| Orange steady | Non-locking alarm with the pump unit stopped |
| Red steady | Locking error, the pump unit cannot be started |

6.3.3 SPEED (speed bar)

It consists of 10 LEDs, each representing, in percentage steps between 10 and 100%, the speed range between parameter P27 (minimum speed) and parameter P26 (maximum speed).

| LED bar | Status |
|--------------------|--|
| On | Motor in operation; the speed corresponds to the percentage step represented by the LEDs ON in the bar (e.g.: 3 LEDs ON = speed 30%) |
| First LED flashing | Motor in operation; the speed is lower than the absolute minimum, P27 |
| Off | Motor stopped |

6.3.4 COM (communication)

Condition 1

- The communication bus protocol is the Modbus RTU protocol; the P50 parameter is set to the Modbus value
- No optional communication module is used.

| LED | Status |
|-------------------------------|---|
| Off | The unit cannot detect any valid Modbus messages on the terminals provided for the communication bus |
| Green steady | The unit has detected a communication bus on the provided terminals and has recognised the correct addressing |
| Flashing green light | The unit has detected a communication bus on the provided terminals and has not been addressed correctly |
| From green steady to off | The unit has not detected a valid Modbus RTU message for at least 5 seconds |
| From green steady to flashing | The unit has not been addressed correctly for at least 5 seconds |

Condition 2

- The communication bus protocol is the BACnet MS/TP protocol; the P50 parameter is set to the BACnet value
- No optional communication module is used.

| LED | Status |
|-----------|--|
| Off | The unit has received no valid requests from other BACnet MS/TP devices for at least 5 seconds |
| On steady | The unit is exchanging information with another BACnet MS/TP device |

Condition 3

- A multi-pump control mode is selected (e.g. MSE or MSY)
- No optional communication module is used.

| LED | Status |
|-----------|--|
| Off | The unit has received no valid requests from other pumps through the multi-pump BUS for at least 5 seconds |
| On steady | The unit is exchanging information with another pump through the multi-pump BUS |

Condition 4

The optional communication module is being used.

| LED | Status |
|----------|--|
| Off | RS485 or wireless connection faulty or missing |
| Flashing | The unit is exchanging information with the communication module |











6.3.5 Unit of measurement

| LED on | Measurement active | Notes |
|--------|-------------------------|--|
| 10xRPM | Impeller rotation speed | The display shows the speed in 10xRPM |
| BAR | Hydraulic head | The display shows the value of the head in bar |
| PSI | | The display shows the value of the head in psi |

6.4 Display

6.4.1 Main visualization































| Display | Mode | Description |
|---------|----------|---|
| | OFF | Contacts 11 and 12 (single-phase version) or 13 and 14 (three-phase version) are not short-circuited. Note: It has lower display priority than STOP mode. |
| | STOP | <p>Pump stopped manually.</p> <p>If the pump is switched on after setting P04 = OFF (see Par. 6.5.1), it is stopped so that the motor is not in operation, and STP flashes (→).</p> <p>To manually stop the pump:</p> <ul style="list-style-type: none"> Example A. HCS, MES, MSY control modes with initial required value (head) of 4.20 bar and minimum value 0.5 bar: → press → once. Example B. ACT control mode with initial required value (speed) of 200 10xRPM and minimum value 80 10xRPM: → press → once. |
| | ON | <p>Pump on; the motor starts following the selected control mode.</p> <p>It appears for a few seconds when contacts 11 and 12 (single-phase version) or 13 and 14 (three-phase version) are short circuited and the pump is not in STOP mode.</p> <p>To manually set the pump to ON mode:</p> <ul style="list-style-type: none"> Example A. HCS, MES, MSY control modes that reach a required value (head) of 4.20 bar, starting with a minimum value of 0.5 bar after manual stop: → press → → once after a few seconds... → . Example B. ACT control mode that reaches a requested value (speed) of 200 10xRPM, starting with a minimum value of 80 10xRPM after manual stop: → press → → once, and after a few seconds... → . <p>With the pump in operation, it is possible to display the Actual Head and the Actual Speed:</p> <ul style="list-style-type: none"> Example A HCS, MES, MSY control modes with Actual Head 4.20 bar and corresponding Actual Speed of 352 10xRPM: → + → → after 10 seconds or + → . Example B ACT control mode with Actual Speed 200 10xRPM and corresponding Actual Head of 2.37 bar: → + → → after 10 seconds or + → . |
| | Stand-by | <p>The analog input is configured as speed set (P40 = or), the read value is in the Stand-by zone and P34 = STP (see paragraph 6.6.1)</p> <p>Note: It has lower display priority than STOP mode</p> |

| | | |
|---|----------------|---|
|  | Lock | <p>To lock press  +  for 3 seconds; the lock will be confirmed by the temporary appearance of .</p> <p>It appears if a button is pressed (with the exception of ) after a locking procedure had been completed.</p> <p>Note: the function connected with START/STOP  is always disabled. At startup the buttons are locked, if they were locked at the previous switch off</p> <p>Default: unlocked</p> |
|  | Unblock | <p>To unlock press  + , for three seconds; the unlock will be confirmed by the temporary appearance of .</p> <p>Note: At startup the buttons are unlocked, if they were unlocked at the previous switch off</p> <p>Default: unlocked</p> |



6.4.2 Parameters menu visualization

The parameter menu gives the possibility to:

- select all the parameters (see Par. 6.5)
- access Parameter View / Editing (see Par. 6.2).

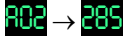

| Parameter | Description |
|---|--|
| Power on | <p>If after switching ON, parameter Menu View is accessed with P23 = ON, P20 flashes  → .</p> <p>Enter the password to display and change the parameters.</p> |
| Password timeout | <p>If with P23 = ON no button is pressed for over 10 minutes from the last parameter Menu View, both the view and the editing of the parameters are disabled.</p> <p>Enter the password again to display and change the parameters.</p> |
| Parameters Menu | <p>With P23 = OFF, or after entering the password (P20), it is possible to both display and edit the parameters. When accessing the Parameter Menu, the display shows:</p> <p> →   →  ...  → </p> <p>The flashing parameter, indicating the selection possibility.</p> |
| Parameters Editing/Visualization | <p>The value of a parameter may be changed using the buttons, or the Modbus and BACnet communication protocols.</p> <p>When returning to the Parameter Menu, the displayed parameter index is increased automatically. For further information see Par. 6.5.</p> <ul style="list-style-type: none"> • Example A (P20) from 000 to 066:  →  →  →  →  →  ... until ... →  →  →  sets the desired value →  →  • Example 2 (P26) from 360 to 300:  →  →  →  →  →  ... until... →  →  →  sets the desired value → →  →  |

6.4.3 Alarms and errors visualization





| Parameter | Description |
|--------------|---|
| Alarm | In case of alarm, the corresponding code appears on the display in alternation to the Main View. For example:  (ex. BAR)  ... |
| Error | In case of error, the corresponding identification code appears on the display. For example:   ... |

6.5 Software parameters

Parameters are marked differently in the manual depending on their type:

| Mark | Parameter type |
|---|---|
| No mark | Applicable to all units |
|  | Global parameter, shared by all pumps in the same multi-pump system |
|  | Read only |

6.5.1 Status Parameters

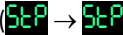
| No. | Parameter | Unit of measurement | Description |
|------------|--|---------------------|---|
| P01 | Required value  | bar/psi/ rpmx10 | This parameter shows the SOURCE and the VALUE of the active required value. Visualization cycles between SOURCE and VALUE occur every 3 seconds. SOURCES: <ul style="list-style-type: none"> SP (SP): internal required value Setpoint related to the control mode selected. VL (UL): external required value speed Setpoint related to 0-10V input. VALUE can represent a Speed or a Head, depending on the selected control mode: in case of Head, the unit of measure is defined by parameter P41. |
| P02 | Effective Required Value  | bar/psi | Active required value calculated based on parameters P58 and P59. This parameter is effective only in control modes MSE or MSY. For further information on the calculation of P02, see Par. 6.6.3. |
| P03 | Regulation Restart Value [0÷100]  | % | It defines the start value after the stop of the pump, as a percentage of the P01 value. If the required value is met and there is no further consumption, then the pump stops. The pump starts again when the pressure drops below P03. P03 is valid when: <ul style="list-style-type: none"> Different from 100% (100%=off) The control mode is HCS, MSE or MSY. Default: 100%. |
| P04 | Auto-start [OFF-ON]  | | If P04 = ON, then the pump starts automatically following a power supply disconnection. If the pump is switched on after setting P04 = OFF (see Par. 6.5.1), it is stopped so that the motor is not in operation, and STP flashes  Default: ON. |





| | | | |
|-----|--------------------------|--------|---|
| P05 | Operating time months | | Total months of connection to the electric mains, to add to P06. |
| P06 | Operating time hours | h | Total hours of connection to the electric mains, to add to P05. |
| P07 | Motor Time Months | | This parameter shows the total operating time months, to be added to P08. |
| P08 | Motor time hours | h | This parameter shows the total operating time hours, to be added to P07. |
| P09 | 1st error | | This parameter stores the last error occurred in chronological order. The information displayed switches through the values: <ul style="list-style-type: none"> • (Exx): xx indicates the error code • (Hyy): yy is the value of hours referred to P05-P06 when the error Exx happened • (Dww): ww is the value of days referred to P05-P06 when the error Exx happened • (Uzz): zz is the value of weeks referred to P05-P06 when the error Exx happened Example of visualisation: |
| P10 | 2nd error | | Saves the penultimate error in chronological occurred. Other characteristics: like P09. |
| P11 | 3rd error | | Saves the third from the last error in chronological occurred. Other characteristics: like P09. |
| P12 | 4th error | | Saves the fourth from the last error in chronological occurred. Other characteristics: like P09. |
| P13 | Power Module Temperature | °C | Temperature of the power module. |
| P14 | Inverter Current | A | This parameter shows the actual current supplied by the frequency converter. |
| P15 | Inverter Voltage | V | This parameter shows the actual estimated input voltage of the frequency converter. |
| P16 | Motor Speed | rpmx10 | This parameter shows the actual motor rotational speed. |
| P17 | Software version | | This parameter shows the Control Board software version. |

6.5.2 Settings Parameters

| No. | Parameter | Description |
|-----|---------------------------|---|
| P20 | Password entering [0÷999] | The user can enter here the system password, which gives access to all system parameters: this value is compared with the one stored in P22. When a correct password is entered, the system remains unlocked for 10 minutes. |
| P21 | Jog mode [MIN÷MAX*] | It deactivates the internal controller of the unit and forces the actual Control Mode (ACT): the motor starts and the value of P21 becomes the temporary ACT setpoint. It can be changed by just entering a new value on P21 without confirming it; otherwise, it causes immediate exit from temporary control. |
| P22 | System password [1÷999] | This is the system password, and must be the same as the password entered in P20. Default: 66. |
| P23 | Lock Function [OFF, ON] | By using this function, the user can lock or unlock parameter setting in the main menu. When ON, enter the P20 password to change the parameters. Default: ON. |

* Depending on the type of pump used

6.5.3 Drive Configuration Parameters

| No. | Parameter | Unit of measurement | Description |
|-----|--|---------------------|---|
| P25 | Control mode [ACT, HCS, MSE, MSY] | | This parameter sets the Control Mode (default value: HCS) |
| | | | <p>ACT: Actuator mode. A single pump maintains a fixed speed at any flow rate. ACT will always try to minimize the difference between the speed setpoint and the actual rotational speed of the motor.</p> |
| | | | <p>HCS: Hydrovar® Controller mode for single pump. The pump maintains a constant pressure at any flow rate: the Hydrovar® algorithm, based on the set of parameters from P26 to P37 (see Par. 6.5.3), is implemented. HCS mode must be set in conjunction with the use of an absolute reading pressure sensor installed in the hydraulic circuit, which supplies to the unit the pressure feedback signal: HCS will always try to minimize the difference between the pressure setpoint and the pressure feedback signal.</p> |
| | | | <p>MSE: Hydrovar® Controller mode for multiple pumps in Serial Cascade. Pumps are managed in series: only the last activated pump modulates the speed to maintain the set pressure, while all the others in operation rotate at the maximum speed. The set of pumps, connected to each other through the multi-pump protocol, maintains a constant pressure at any flow rate: the Hydrovar® algorithm, based on the set of parameters from P26 to P37 (see Par. 6.5.3), is implemented. MSE mode must be set in conjunction with the use of absolute reading pressure sensors, one for each pump, which supply to the set the pressure feedback signal: MSE will always try to minimize the difference between the pressure setpoint and the pressure feedback signal. Using the multi-pump protocol, it is possible to connect up to 3 pumps, all of the same type and with the same power.</p> |
| | | | <p>MSY: Hydrovar® Controller mode for multiple pumps in Synchronous Cascade. The pumps are synchronised: they all keep the set pressure and operate at the same speed. Other characteristics: as for MSE mode.</p> |
| P26 | Max RPM set [ACT set÷Max*]  | rpmx10 | Maximum pump speed setup. |
| P27 | Min RPM set [Min*÷ACT set]  | rpmx10 | Minimum pump speed setup. |
| P28 | Ramp 1 [1÷250]  | s | This parameter adjusts the fast acceleration time. It affects the control of the pump for HCS, MSE and MSY control modes (also see Par. 6.6.2). Default: 3 s. |
| P29 | Ramp 2 [1÷250]  | s | This parameter adjusts the fast deceleration time It affects the control of the pump for HCS, MSE and MSY control modes (also see Par. 6.6.2). Default: 3 s. |
| P30 | Ramp 3 [1÷999]  | s | This parameter adjusts the slow acceleration. It determines: <ul style="list-style-type: none"> • The adjustment speed, in case of small flow rate variations • The constant outgoing pressure. The ramp depends on the system being controlled, and affects the control of the pump in HCS, MSE and MSY modes (also see Par. 6.6.2). Default: 35 s. |

* Depending on the type of pump used

| | | | |
|-----|--|--------|--|
| P31 | Ramp 4 [1÷999] | s | Adjustment of the slow deceleration time (also see Par. 6.6.2). Other characteristics: as for Ramp 3. |
| P32 | Ramp Speed Min Acceleration [2.0÷25.0] | s | This parameter sets the fast acceleration time. It represents the acceleration ramp used by the controller until the minimum speed of the pump is reached (P27). It affects the control of the pump for HCS, MSE and MSY control modes (also see Par. 6.6.2). Default: 2.0 s. |
| P33 | Ramp Speed Min Deceleration [2.0÷25.0] | s | This parameter sets the fast deceleration time. It represents the deceleration ramp used by the controller for stopping the pump once the minimum speed of the pump is reached (P27). It affects the control of the pump for HCS, MSE and MSY control modes (also see Par. 6.6.2). Default: 2.0 s. |
| P34 | Speed Min Configuration [STP, SMI] | | This parameter defines the operation of the controller once the minimum speed of the pump P27 is reached: <ul style="list-style-type: none"> STP (STP): once the required pressure is reached and no further request is made, the pump speed decreases to the P27 value: the pump continues to run for the selected time interval (P35), after which it stops automatically. SMI (SMI): once the required pressure is reached and no further request is made, the pump speed decreases to the selected P27 value: the pump continues to run at the same speed. This parameter affects the control of the pump for HCS, MSE and MSY control modes. Default: STP |
| P35 | Smin time [0÷100] | s | This parameter sets the time delay before a shut-off below P27 occurs. It is only used if P34 = STP. It affects the control of the pump for HCS, MSE and MSY control modes. Default: 0 s. |
| P36 | Window [0÷100] | % | This parameter sets the ramp control interval, as a percentage of the pressure setpoint. It is used to define the range of pressures, around the setpoint, in which the pump uses slow acceleration and deceleration ramps instead of fast ones. It affects the control of the pump for HCS, MSE and MSY control modes (also see Par. 6.6.2). Default: 10%. |
| P37 | Hysteresis [0÷100] | % | This parameter sets the slow ramp hysteresis, as a percentage of P36. It helps define the pressure range, around the setpoint, in which the pump goes from slow acceleration ramp (P28) to slow deceleration ramp (P29). The parameter affects the control of the pump for HCS, MSE and MSY control modes (also see Par. 6.6.2). Default: 80%. |
| P38 | Speed Lift [0÷MAX*] | rpmx10 | This parameter sets the speed limit after which the linear increase of the actual require value starts (P02), until the total increase (P39) at maximum speed (P26). Default: P27. |
| P39 | Lift Amount [0÷200] | % | This parameter sets the increase value of the actual required value (P02) at the maximum speed (P26), measured as a percentage of the required value (P01). It determines the increase of the required pressure set, useful to compensate for flow resistances at high flow rates. Default: 0. |

* Depending on the type of pump used

6.5.4 Sensor Configuration Parameters





| No. | Parameter | Unit of measurement | Description |
|-----|--|---------------------|--|
| P40 | Sensor selection [PI, ISP, USP] | | Analog input configuration setup: - PI absolute reading pressure sensor - ISP 4-20 mA input as speed reference - USP 0-10 V input as speed reference Default: PI |
| P41 | Pressure Sensor Unit Of Measure [BAR, PSI] | | This parameter sets the unit of measure (BAR, PSI) for the pressure sensor. It affects the head view LED parameter (see Par. 6.3.4). Default: bar. |
| P42 | Full scale value for pressure Sensor 1 4÷20mA [0.0÷25.0BAR] / [0.0÷363PSI] | bar/psi | Setting of the full scale value of the 4÷20mA pressure sensor connected to analog inputs 9 and 10 for the single-phase version, and inputs 17 and 18 for the three-phase version. Default: depending on the type of pump. |
| P44 | Zero Pressure Auto-Calibration | bar/psi | This parameter lets the user perform the initial auto-calibration of the pressure sensor. It is used to compensate for the offset signal of the sensor at zero pressure caused by the tolerance of the sensor itself. Procedure: 1. Access P44 when the hydraulic system is at 0 pressure (no water inside), or with the pressure sensor disconnected from the piping: the actual value of 0 pressure is displayed. 2. Start the auto-calibration by pressing or (see Par. 6.2). 3. At the end of the auto-calibration, the 0 (zero) pressure is displayed, or the “---” (---) message, if the sensor signal is out of the permitted tolerance. |
| P45 | Pressure Minimum Threshold [0÷42] | bar/psi | Setting the minimum pressure threshold. If the system pressure falls below this threshold for the time set in P46, a low pressure error E14 is generated. Default: 0 bar. |
| P46 | Pressure Minimum Threshold - Delay Time [1÷100] | s | Time delay setup. This parameter sets the time delay during which the unit remains idle with a system pressure below P45, before generating the low pressure error E14. Default: 2 s. |
| P47 | Pressure Minimum Threshold – Automatic Error Reset [OFF, ON] | | Enabling/disabling of automatic unit attempts in case of low pressure error. Default: ON. |
| P48 | Lack Of Water Switch Input [DIS, ALR, ERR] | | This parameter enables/disables the management of the lack of input water (see Par. 4.3.3, terminals 13 and 14 for the single-phase version, 11 and 12 for the three-phase version). It defines the behaviour of the unit when the lack of water input is enabled and the switch is open: <ul style="list-style-type: none"> (DIS): the unit doesn't manage the information coming from the "lack of water" input (ALr): the unit reads the "lack of water" Input (enabled) and reacts, at the opening of the switch, by displaying the corresponding alarm A06 on the display, and keeping the motor running (Err): Err, the unit reads the Lack Of Water Input (enabled) and reacts, at the opening of the switch, by stopping the motor and generating the corresponding error E11. The error condition is removed when the switch closes again and the motor is started. Default: ERR. |

6.5.5 RS485 Interface Parameters

| No. | Parameter | Unit of measurement | Description |
|-----|--|---------------------|--|
| P50 | Communication protocol [MOD, BAC] | | This parameter selects the specific protocol on the communication port: <ul style="list-style-type: none"> • MOD (MOD): Modbus RTU • BAC (BAC): BACnet MS/TP. Default: MOD. |
| P51 | Communication protocol - Address [1÷247]/[0÷127] | | This parameter sets the desired address for the unit, when connected to an external device, depending on the protocol selected in P50: <ul style="list-style-type: none"> • MOD: any value in the 1÷247 range • BAC: any value in the 0÷127 range. |
| P52 | Comm Protocol – BAUDRATE [4.8, 9.6, 14.4, 19.2, 38.4, 56.0, 57.6 KBPS] | kbps | This parameter sets the desired baud rate for the communication port. Default: 9.6 kbps. |
| P53 | BACnet Device ID Offset [0÷999] | | This parameter sets the hundreds, tens and units of the BACnet Device ID. Default: 002. Device ID default: 84002. |
| P54 | Comm Protocol – Configuration [811, 812, 8E1, 861] | | This parameter sets the length of the data bits, the parity and the length of the STOP bits. |

6.5.6 Multi-pump configuration parameters

All these parameters affect MSE and MSY control modes.

| No. | Parameter | Unit of measurement | Description |
|-----|--|---------------------|--|
| P55 | Multipump – Address [1÷3] | | This parameter sets the address of each pump based on the following criteria: <ul style="list-style-type: none"> • Each pump needs an individual pump address (1÷3) • Each address may only be used once. Default: 1. |
| P56 | Multipump – Max Units [1÷3]  | | This parameter sets the maximum number of pumps operating at the same time. Default: 3. |
| P57 | Multipump – Switch Interval [0÷250]  | h | Setpoint of the main pump forced switch interval. If the pump with priority 1 works in continuous mode until this time is reached, the switch between this pump and the next is forced. If on the other hand, the system stops completely due to the setpoint being reached, with the next start priority 1 will be assigned in a way to ensure an even distribution of the operating hours of all pumps. Default: 24 h. |
| P58 | Multipump – Actual Value Increase [0.0÷25.0BAR] / [0.0÷363PSI]  | bar/psi | This parameter affects the calculation of P02, to improve the Multipump control as described in paragraph 6.6.3. Default: 0.35 bar. |
| P59 | Multipump – Actual Value Decrease [0.0÷25.0BAR] / [0.0÷363PSI]  | bar/psi | This parameter affects the calculation of P02, to improve the multi-pump control as described in paragraph 6.6.3. Default: 0.15 bar. |
| P60 | Multipump – Enable Speed [P27÷P26]  | rpmx10 | This parameter sets the speed that a pump must reach before starting the next assist pump, after a system pressure drop below the difference between P02 and P59. Default: depending on the type of pump. |

| | | | |
|-----|--|--------|--|
| P61 | Multipump Synchronous – Speed Limit [P27÷P26] | rpmx10 | This parameter sets the speed limit below which the first assist pump stops. Default: depending on the type of pump. |
| P62 | Multipump Synchronous – Window [0÷100] | rpmx10 | This parameter sets the speed limit for the stop of the next assist pump. Default: 150 rpmx10. |
| P63 | Multipump – Priority | | This parameter shows the pump priority value within the multi-pump set. This parameter displays the following information: Pr1 (Pr1) .. Pr3 (Pr3) or Pr0 (Pr0) where: <ul style="list-style-type: none"> Pr1 .. Pr3, indicate that the pump is communicating with others pumps and its priority order, is equal to the visualized number. Pr0 indicates that the pump does not detect the communication with other pumps and is considered alone in the multi-pump bus |
| P64 | Multipump – Revision | | This parameter shows the multi-pump protocol revision value used. |

6.5.7 Test Run Configuration Parameters

Test Run is a function that starts the pump after the last stop, in order to prevent it from blocking.

| No. | Parameter | Unit of measurement | Description |
|-----|---|---------------------|--|
| P65 | Test Run – Time Start [0÷100] | h | This parameter sets the time after which, once the pump has stopped for the last time, the Test Run will start. Default: 100 h. |
| P66 | Test Run – Speed [Min÷Max] | rpmx10 | This parameter sets the pump rotational speed for the Test Run. The Min and Max speeds depend on the pump type. Default: 200 rpmx10. |
| P67 | Test Run – Time Duration [0÷180] | s | This parameter sets the duration of the Test Run. Default: 10 s. |

6.5.8 Special Parameters

| No. | Parameter | Unit of measurement | Description |
|-----|---|---------------------|---|
| P68 | Default Values Reload [NO, YES] | | If set to RES, after confirmation this parameter performs a factory reset that reloads the default parameter values. |
| P69 | Avoid Frequent Parameters Saving [NO, YES] | | This parameter limits the frequency with which the unit stores the required value P02 in the EEPROM memory, in order to extend its life. This could be particularly useful in applications with BMS control devices that require continuous variation of the value for fine tuning purposes. Default: NO. |

6.6 Technical references

6.6.1 Example: ACT control mode with analog input

The diagram of the ACT control mode is shown in the figure.

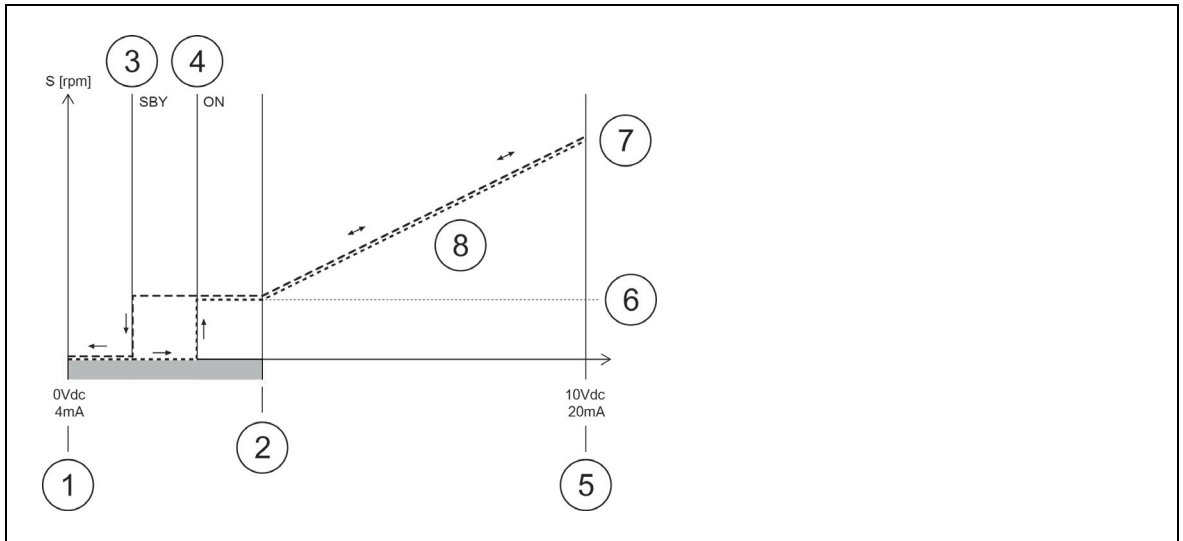

| No. | Description |
|-----------|---|
| 1 | ZERO point (0Vdc - 4mA) = minimum analog signal value |
| 2 | Adjustment start point |
| 3 | Standby point (SBY) = 1/3 of the hysteresis zone |
| 4 | ON point (ON) = 2/3 of the hysteresis zone |
| 5 | MAX point (10Vdc - 2mA) = maximum analog signal value |
| 6 | Motor minimum speed (Parameter P27) |
| 7 | Motor maximum speed (Parameter P26) |
| 8 | Adjustment zone |
| 3 - 4 - 2 | Minimum speed operation zone (Parameter P27) |
| 1 to 2 | Hysteresis zone |
| 1 - 3 - 4 | Standby zone |

For further information on the control mode and the ACT regulation parameters, see Par. 6.5.3. and 6.5.5

Examples:

| | |
|--|--|
| <p>Calculation of the adjustment start point for P40 = ISP (4-20 mA analog signal)</p> | <ul style="list-style-type: none"> • P27 = 900 • P26 = 3600 • Calculation of the adjustment start point value = (maximum value - zero point) x (P27/P26) + zero point = (20-4) x (900/3600) + 4 = 8 mA |
| <p>Calculation of the adjustment start point for P40 = VSP (0-10 Vdc analog signal)</p> | <ul style="list-style-type: none"> • P27 = 900 • P26 = 3600 • Calculation of the adjustment start point value = (maximum value - zero point) x (P27/P26) + zero point = (10-0) x (900/3600) + 0 = 2.5 V |

6.6.2 Example: Ramp Settings

The illustration shows the ramp settings.

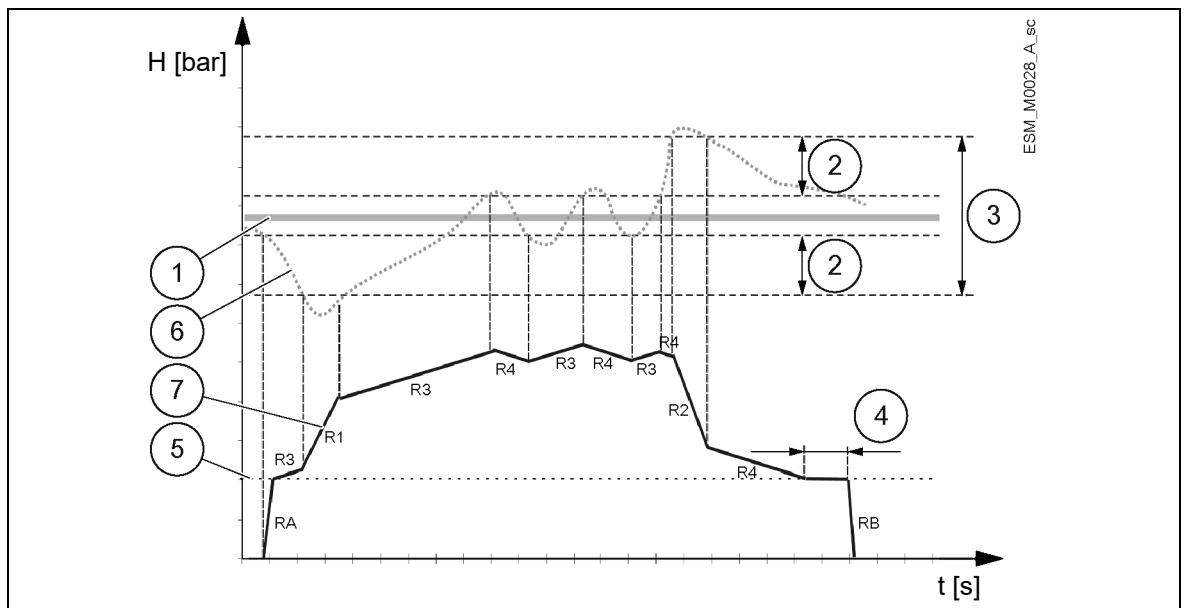

| No. | Description |
|-----|---|
| 1 | P01 (Required Value) |
| 2 | P37 (Adjustment hysteresis) as a % of P36 (Adjustment window) |
| 3 | P36 (Adjustment window) as a % of P01 (Required Value) |
| 4 | P35 (Minimum speed - Duration) |
| 5 | P27 (Minimum speed) |
| 6 | → Actual Head |
| 7 | → Actual Speed |
| RA | → P32 (Acceleration ramp at startup) |
| RB | → P32 (Deceleration ramp at shutdown) |
| R1 | → P28 (Ramp 1) - Fast ramp speed increase |
| R2 | → P29 (Ramp 2) - Fast ramp speed decrease |
| R3 | → P30 (Ramp 3) - Slow ramp speed increase |
| R4 | → P31 (Ramp 4) - Slow ramp speed decrease |

For further information on the adjustment of the ramps, see Par. 6.5.3.

6.6.3 Example: Effective Required Value

Pumps activation in cascade modes:

1. Lead pump reaches its P60 (Enable Speed).
2. Actual value falls to the cut in-value of the 1st assist pump.
The 1st assist pump switches on automatically. (Cut-in value = P01 (Required Value) - P59 (Actual Value Decrease))
3. A new required value, P02 (Effective Required Value) is calculated after the start up.

Calculation of Effective Required Value in Cascade Serial (MSE):

K = number of active pumps
Pr = pump priority

$$P02 \text{ (Actual Required Value)} = P01 \text{ (Required Value)} + (K - 1) * P58 \text{ (Actual Value Increase)} - (Pr - 1) * P59 \text{ (Actual Value Decrease)}$$

Calculation of Effective Required Value in Cascade Synchronous (MSY):

K = number of active pumps ($K \geq Pr$)

$$P02 \text{ (Actual Required Value)} = P01 \text{ (Required Value)} + (K - 1) * (P58 - P59)$$

Behaviour of P58 (Actual Value Increase) and P59 (Actual Value Decrease):

- if P58 (Actual Value Increase) = P59 (Actual Value Decrease) → Pressure constant, independent of how many pumps are in operation.
- if P58 (Actual Value Increase) > P59 (Actual Value Decrease) → Pressure rises when assist pump switches on.
- if P58 (Actual Value Increase) < P59 (Actual Value Decrease) → Pressure decreases when assist pump switches on.

7 Maintenance

Precautions



DANGER: Electrical hazard

- Before attempting to use the unit, check that it is unplugged and that the pump and the control panel cannot restart, even unintentionally. This also applies to the auxiliary control circuit of the pump.
 - Before any interventions on the unit, the network power supply and any other input voltages must be disconnected for the minimum time indicated in Table 9 (the capacitors of the intermediate circuit must be discharged by the built-in discharge resistors).
-

1. Make sure that the cooling fan and the vents are free from dust.
 2. Make sure that the ambient temperature is correct according to the limits of the unit.
 3. Make sure that qualified personnel perform all modifications of the unit.
 4. Make sure that the unit is disconnected from the power supply before any work is carried out. Always consider the pump and motor Instruction.
-



WARNING: Danger of exposure to magnetic field

If the rotor is removed or reinserted in the motor body, the existing magnetic field can:

- be dangerous for people wearing peacemakers and medical implants
 - by attracting metal parts, cause personal injuries and damage to the bearings.
-

Function and parameter control

In case of changes to the hydraulic system:

1. Make sure that all functions and parameters are correct.
2. Adjust the functions and parameters if necessary.
3. Also refer to the “Quick Startup Guide” and the “Installation, Operation and Maintenance Manual” of e-SVE, e-HME, VME and e-SVIE pumps supplied with the product.

8 Troubleshooting

In case of alarm or error, the display shows an ID code and the STATUS LED turns on (also see Par. 6.3.2).

In case of several alarms and/or errors, the display shows the main one.

Alarms and errors:

- are saved with date and time
- can be reset by switching the unit off for at least 1 minute.

Errors cause the triggering of the status relay on the following terminal box pins:

- single-phase version: pins 4 and 5
- three-phase version: pins 24 and 25

8.1 Alarm codes

| Code | Description | Cause | Solution |
|------|-------------------------------|---------------------------------------|--|
| A03 | Derating | Temperature too high | <ul style="list-style-type: none"> • Lower the room temperature • Lower the water temperature • Lower the load |
| A05 | Data memory alarm | Data memory corrupted | <ol style="list-style-type: none"> 1. Reset the default parameters using parameter P68 2. Wait 10 s 3. Restart the pump If the problem continues, contact Xylem or the Authorised Distributor |
| A06 | LOW alarm | Lack of water detection (if P48= ALR) | Check the water level inside the tank |
| A15 | EEPROM write failure | Data memory damaged | Stop the pump for 5 minutes and then restart it again; if the problem continues, contact Xylem or the Authorised Distributor |
| A20 | Internal alarm | | Stop the pump for 5 minutes and then restart it again; if the problem continues, contact Xylem or the Authorised Distributor |
| A30 | Multi-pump connection alarm | Corrupted multi-pump connection | <ul style="list-style-type: none"> • Check the condition of the connection cables • Check that there are no address discrepancies |
| A31 | Loss of multi-pump connection | Loss of multi-pump connection | Check the condition of the connection cables |

8.2 Error codes

| Code | Description | Cause | Solution |
|------|------------------------------|---|--|
| E01 | Internal communication error | Internal communication lost | Stop the pump for 5 minutes and then restart it again; if the problem continues, contact Xylem or the Authorised Distributor |
| E02 | Motor overload error | <ul style="list-style-type: none"> • Excessive motor current • Current absorbed by the motor too high | Stop the pump for 5 minutes and then restart it again; if the problem continues, contact Xylem or the Authorised Distributor |

| Code | Description | Cause | Solution |
|------|-----------------------------------|--|--|
| E03 | DC-bus overvoltage error | <ul style="list-style-type: none"> DC-bus overvoltage External conditions cause the operation of the pump from generator | Check: <ul style="list-style-type: none"> the system configuration the position and integrity of the non-return valves |
| E04 | Rotor blocked | <ul style="list-style-type: none"> Motor stall Loss of rotor synchronism or rotor blocked by external materials | <ul style="list-style-type: none"> Check that there are no foreign bodies preventing the pump from turning Stop the pump for 5 minutes and then start it again If the problem continues, contact Xylem or the Authorised Distributor |
| E05 | EEPROM Data memory error | EEPROM Data memory corrupted | Stop the pump for 5 minutes and then restart it again; if the problem continues, contact Xylem or the Authorised Distributor |
| E06 | Grid voltage error | Voltage supply out of operating range | Check: <ul style="list-style-type: none"> the voltage the connection of the electric system |
| E07 | Motor winding temperature error | Motor thermal protection trip | <ul style="list-style-type: none"> Check for impurities near the impeller and rotor. Remove them if necessary Check the conditions of installation, and the water and air temperature Wait for the motor to cool down If the error persists, stop the pump for 5 minutes and then start it again If the problem continues, contact Xylem or the Authorised Distributor |
| E08 | Power module temperature error | Frequency converter thermal protection trip | Check the conditions of installation, and the air temperature |
| E09 | Generic hardware error | Hardware error | Stop the pump for 5 minutes and then restart it again; if the problem continues, contact Xylem or the Authorised Distributor |
| E11 | LOW error | Lack of water detection (if P48=ERR) | Check the water level inside the tank |
| E12 | Pressure sensor error | Missing pressure sensor (not present in ACT mode) | Check the condition of the sensor connection cables |
| E14 | Low pressure error | Pressure below minimum threshold (not present in ACT mode) | Check the settings of parameters P45 and P46 |
| E15 | Loss of phase error | One of the three power supply phases is missing (three-phase versions only) | Check the connection to the power supply network |
| E30 | Multi-pump protocol error | Incompatible multi-pump protocol | Bring all the units to the same firmware version |
| E44 | External analogue reference error | External analogue signal missing or out of range (if P40 = ISP) | Check: <ul style="list-style-type: none"> the P40 parameter setting External analog signal source and cables (terminals 9-10 for the single-phase version, terminals 17-18 for the three-phase version) |

See also Par. 6.3.2 and Par. 6.4.3.

9 Technical Information

| | e-SM Drive model | | | | | | | | | | | |
|--|--|-----|-----|-----|-----|--|-----|-----|-----|-----|--------------|--|
| | 103 | 105 | 107 | 111 | 115 | 303 | 305 | 307 | 311 | 315 | 322 | |
| Input | | | | | | | | | | | | |
| Input frequency [Hz] | 50/60 ± 2 | | | | | | | | | | | |
| Main supply | LN | | | | | L1 L2 L3 | | | | | | |
| Nominal input voltage [V] | 208÷240 ±10% | | | | | 208÷240 / 380÷460 ±10% | | | | | 380÷460 ±10% | |
| Maximum current absorbed (AC) in continuous service (S1) [A] | See data plate | | | | | | | | | | | |
| PDS Efficiency Class | IES2 | | | | | | | | | | | |
| Output | | | | | | | | | | | | |
| Min.÷Max. Speed [rpm] | 800 to 3600 | | | | | | | | | | | |
| Leakage Current [mA] | < 3,5 | | | | | | | | | | | |
| I/O auxiliar + 15VDC power supply [mA] | I _{max} < 40 | | | | | | | | | | | |
| Fault signal relay | 1 x NO V _{max} < 250 [VAC] , I _{max} < 2 [A] | | | | | 1 x NO V _{max} < 250 [VAC] , I _{max} < 2 [A] | | | | | | |
| Motor status relay | - | | | | | 1 x NO V _{max} < 250 [VAC] , I _{max} < 2 [A] | | | | | | |
| EMC (Electro Magnetic Compatibility) | See Par. Declarations. Installations must be performed in accordance with the EMC good practice guidelines (e.g. avoid "eyebolts" on the transmission side) | | | | | | | | | | | |
| Sound pressure L _{pA} [dB(A)] @ [rpm] | < 62 @3000 < 66 @3600 | | | | | | | | | | | |
| Insulation class | 155 F | | | | | | | | | | | |
| Protection class | IP 55, Enclosure Type 1 Protect the product from direct sunlight and rainfall | | | | | | | | | | | |
| Relative humidity (storage & operating) | 5%÷95% UR | | | | | | | | | | | |
| Storage temperature [°C] / [°F] | -25÷65 / -13÷149 | | | | | | | | | | | |
| Operating temperature [°C] / [°F] | -20÷50 / -4÷122 | | | | | | | | | | | |
| Air Pollution | Pollution Degree 2 | | | | | | | | | | | |
| Installation altitude a.s.l. [m] / [ft] | < 1000 / 3280 Derating may occur at higher altitudes | | | | | | | | | | | |

9.1 Dimensions and weights

e-SVE, VME and e-HME

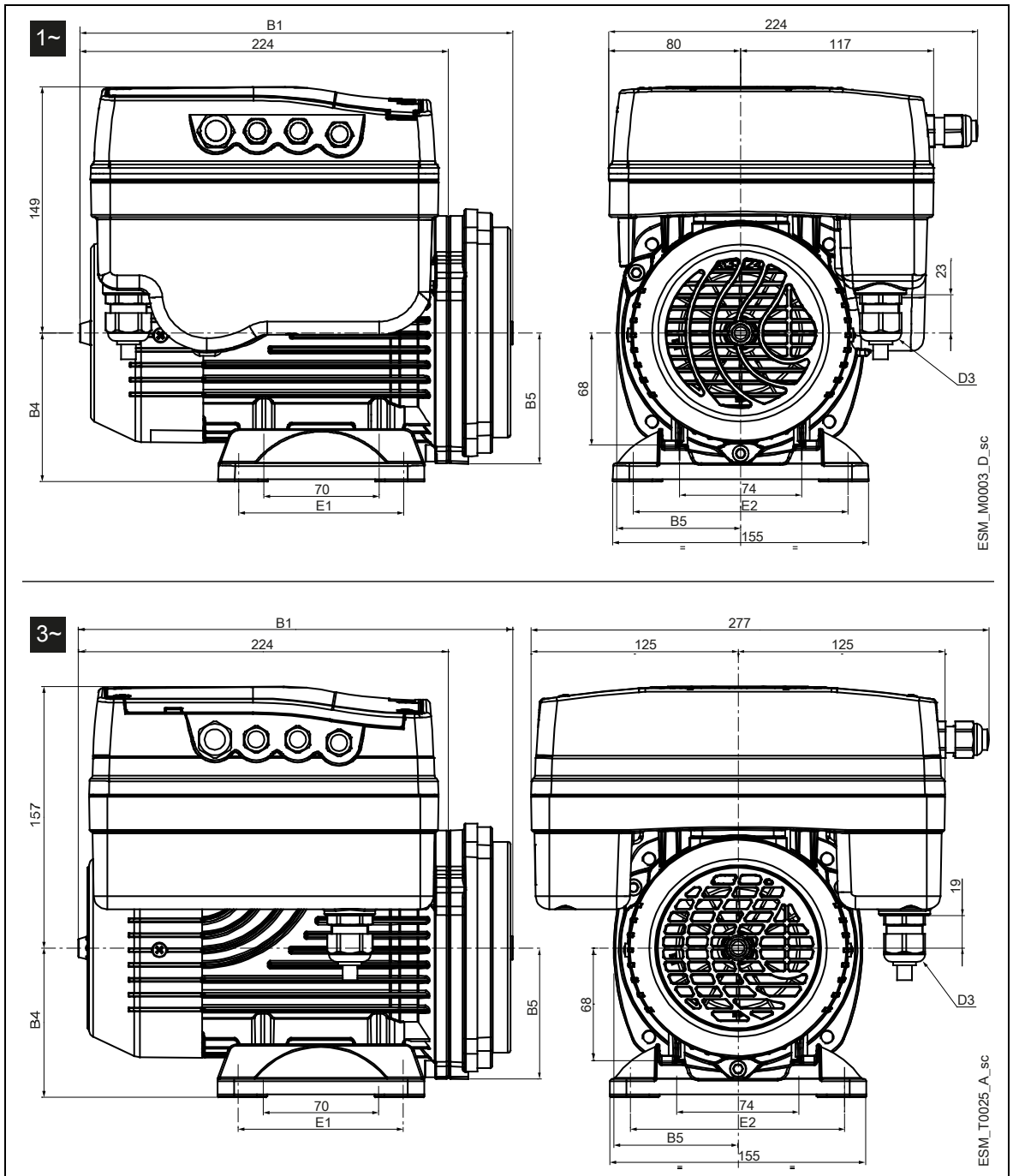

| Model | | | Net weight (motor + drive) [kg] | | | | | B1 | B4 | B5 | D3 | E1 | E2 |
|------------------|--------------|--------------|------------------------------------|------------|-------------------|------------|------|------|----|-----|-------------|-----|-----|
| | | | 1~ | | 3~ | | | [mm] | | | | | |
| | | | 103 105 107 | 111 115 | 303 305 307 | 311 315 | 322 | | | | | | |
| ESM90R...LNEE | | | 7.4 | 8.9 | 13 | 14.4 | 16 | 376 | - | 79 | M20 | - | - |
| ESM90RS8...LNEE | | | 7.3 | 8.8 | 12.8 | 14.2 | 15.8 | 343 | - | 79 | | - | - |
| ESM90R...B14-SVE | | | 7.5 | 9 | 13.1 | 14.5 | 16 | 292 | - | 79 | | - | - |
| ESM90R...B5 | | | 7.5 | 9 | 13.1 | 14.5 | 16 | 292 | - | 100 | | - | - |
| ESM80...HMHA | 80...HMHA US | 80...HMHA EU | 7.5 | 9 | 13 | 14.5 | 16 | 263 | 90 | 79 | | 100 | 125 |
| ESM80...HMHB | 80...HMHB US | 80...HMHB EU | 7.6 | 9.2 | 13.2 | 14.6 | 16.1 | 268 | 90 | 80 | | 100 | 125 |
| ESM80...HMVB | 80...HMVB US | 80...HMVB EU | 7.4 | 8.9 | 13 | 14.4 | 16 | 268 | - | 80 | | - | - |
| ESM80...HMHC | 80...HMHC US | 80...HMHC EU | 7.9 | 9.4 | 13.4 | 14.8 | 16.4 | 272 | 90 | 91 | | 100 | 125 |
| ESM80...HMVC | 80...HMVC US | 80...HMVC EU | 7.6 | 9.1 | 13.2 | 14.6 | 16.2 | 272 | - | 91 | | - | - |
| ESM80...BG | | | 7.3 | 8.8 | 12.9 | 14.3 | 15.9 | 282 | - | 108 | | - | - |
| ESM90R...56J | | | 7.5 | 9.1 | 13 | 14.5 | 16.1 | 307 | 89 | 83 | NPT 1/2" | 76 | 124 |
| ESM90R...56C | | | 7.2 | 8.8 | 12.6 | 14.3 | 15.8 | 294 | - | 83 | | - | - |

... = 103, 105, 107, 111, 115, 303, 305, 307, 311, 315, 322
 - = motor foot not found

e-SVIE

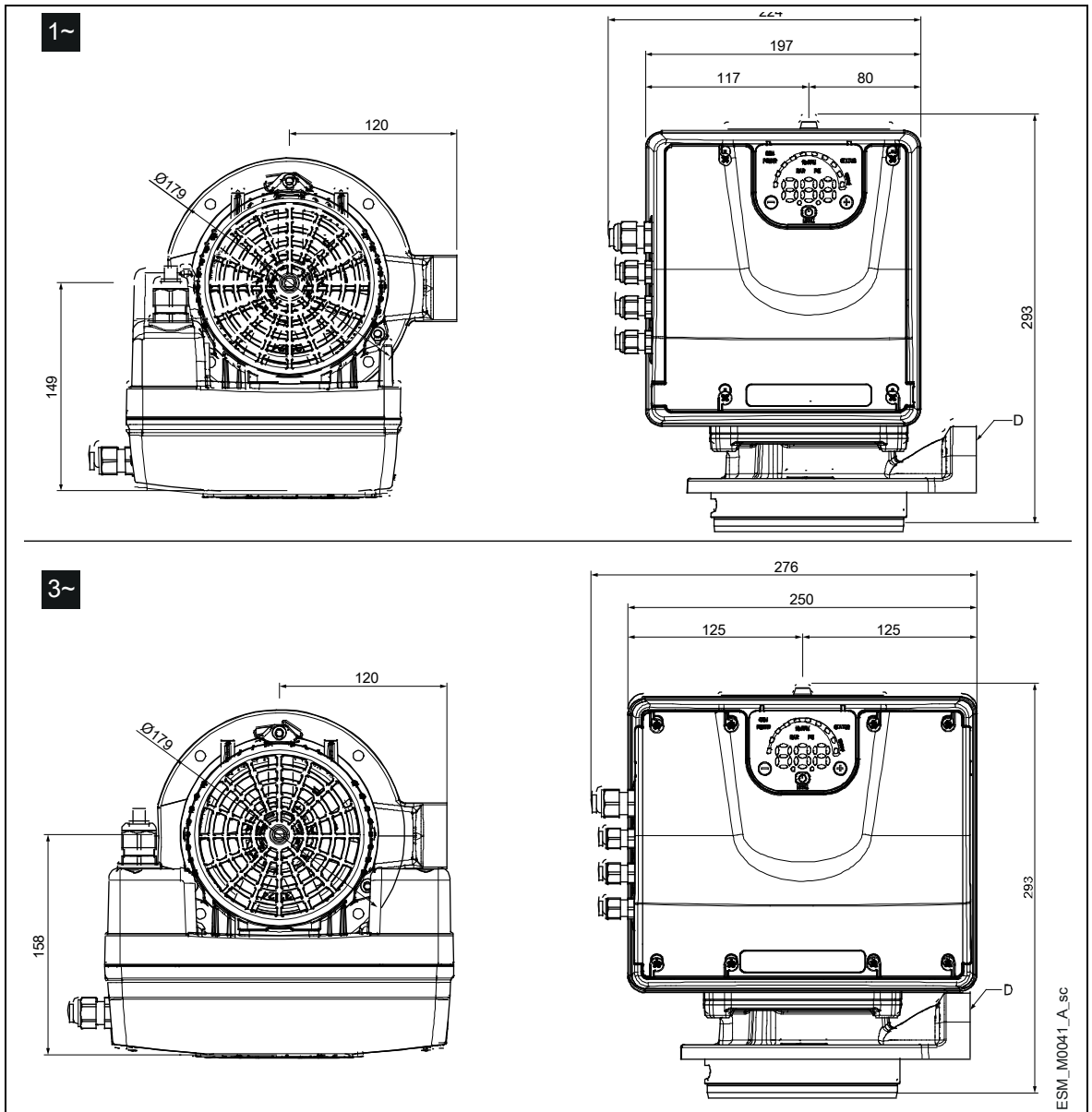

ESM_M0041_A_sc

| Model | Net weight (motor + drive) [kg] | | | | | D |
|-------------------|------------------------------------|-----|-----|-----|-----|----------|
| | 1~ | | 3~ | | | |
| | 103 | 111 | 303 | 311 | 322 | |
| ESM80...SVIE IEC | 105 | 115 | 305 | 315 | - | Rp 3/4" |
| ESM80...SVIE NEMA | 107 | - | 307 | - | - | NPT 3/4" |

... = 103, 105, 107, 111, 115, 303, 305, 307, 311, 315, 322

10 Disposal

10.1 Precautions



WARNING:

The unit must be disposed of through approved companies specialised in the identification of different types of materials (steel, copper, plastic, etc.).



WARNING:

It is prohibited to dispose of lubricating fluids and other hazardous substances in the environment.

10.2 WEEE (EU/EEA)

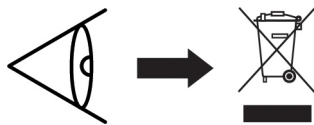

INFORMATION TO USERS pursuant to art. 14 of the Directive 2012/19/EU of the European Parliament and of the Council of 4 July 2012 on waste electrical and electronic equipment (WEEE). The crossed bin symbol on the appliance or on its packaging indicates that the product at the end of its useful life must be collected separately and not disposed of together with other mixed urban waste. Appropriate separate collection for the subsequent start-up of the disused equipment for recycling, treatment and environmentally compatible disposal helps to avoid possible negative effects on the environment and on health and favors the re-use and / or recycling of the materials it is composed of the equipment.

WEEE other than WEEE from private households: The separate collection of this equipment at the end of its life is organized and managed by the producer¹. The user who wants to get rid of this equipment can then contact the producer and follow the system that it has adopted to allow the separate collection of equipment at the end of life, or select a supply chain independently authorized to manage.

10.3 WEEE (UK)

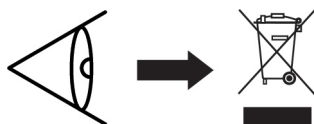

INFORMATION TO USERS pursuant to art. 44 of the The Waste Electrical and Electronic Equipment Regulations 2013 (S. I. 2013 No. 3113). The crossed bin symbol on the appliance or on its packaging indicates that the product at the end of its useful life must be collected separately and not disposed of together with other mixed urban waste. Appropriate separate collection for the subsequent start-up of the disused equipment for recycling, treatment and environmentally compatible disposal helps to avoid possible negative effects on the environment and on health and favors the re-use and / or recycling of the materials it is composed of the equipment.

WEEE other than WEEE from private households: The separate collection of this equipment at the end of its life is organized and managed by the producer². The user who wants to get rid of this equipment can then contact the producer and follow the system that it has adopted to allow the separate collection of equipment at the end of life, or select a supply chain independently authorized to manage.

¹ Producer of EEE as per Directive 2012/19/EU

² Producer of EEE as per WEEE Regulations 2013

11 Declarations

Refer to the specific marking declaration found on the product.

11.1 EC Declaration of Conformity (Original)

Xylem Service Italia S.r.l., with headquarters in Via Vittorio Lombardi 14 - 36075 Montecchio Maggiore VI - Italy, hereby declares that the product:

Pump unit with integrated variable speed drive, with or without pressure transmitter and relative cable (see rating plate)

fulfils the relevant provisions of the following European Directives

- Machinery 2006/42/EC and subsequent amendments (ANNEX II - natural or legal person authorised to compile the technical file: Xylem Service Italia S.r.l.)
- Eco-design 2009/125/EC and subsequent amendments, Regulation (EU) no. 547/2012 and subsequent amendments (water pump) if MEI marked,

and technical standards:

- EN 809:1998+A1:2009, EN 60335-1:2012+A11: 2014+ A13:2017, EN 60335-2-41:2003+A1:2004 +A2:2010, EN 62233:2008
- EN 61800-9-1:2017, EN 61800-9-2:2017.

Montecchio Maggiore, 28/09/2021

Marco Ferretti
Chairman of the Board of Directors



rev.00

11.2 EU Declaration of Conformity (No 19)

1. EMC - Apparatus/Product model:
see rating plate
RoHS - Unique identification of the EEE:
HME, VME, SVE, SVIE.
2. Name and address of the manufacturer:
Xylem Service Italia S.r.l.
Via Vittorio Lombardi 14
36075 Montecchio Maggiore VI
Italy.
3. This declaration of conformity is issued under the sole responsibility of the manufacturer.
4. Object of the declaration:
Pump unit with integrated variable speed drive, with or without pressure transmitter and relative cable (see rating plate).
5. The object of the declaration described above is in conformity with the relevant Union harmonization legislation:
 - 2014/30/EU Directive of 26 February 2014 and subsequent amendments (electromagnetic compatibility)
 - 2011/65/EU Directive of 8 June 2011 and subsequent amendments, including the (EU) 2015/863 Directive (restriction of the use of certain hazardous substances in electrical and electronic equipment).
6. References to the relevant harmonised standards used or references to the other technical specifications, in relation to which conformity is declared:
 - EN 60730-1:2011, EN 61800-3:2004+ A1:2012 (Category C2), EN 55014-1:2006 +A1:2009+A2:2011, EN 55014-2:1997 +A1:2001+A2:2008, EN 61000-6-2:2005, EN 61000-6-3:2007+A1:2011.
 - EN IEC 63000:2018.
7. Notified body: -.
8. Additional information:

RoHS – Annex III – Applications exempt from the restrictions: lead as a binding element in steel and copper alloys [6(a), 6(c)], in solders and in electrical/electronic components [7(a), 7(c)-I].

Signed for and on behalf of: Xylem Service Italia S.r.l.

Montecchio Maggiore, 28/09/2021

Marco Ferretti
Chairman of the Board of Directors



rev.00

Lowara is a trademark of Xylem Inc. or one of its subsidiaries.

11.3 UKCA Declaration of Conformity (Original)

Xylem Service Italia S.r.l., with headquarters in Via Vittorio Lombardi 14 - 36075 Montecchio Maggiore VI - Italy, hereby declares that the product:

Pump unit with integrated variable speed drive, with or without pressure transmitter and relative cable (see rating plate)

fulfils the relevant provisions of the following legal acts

- S.I. 2008/1597 - Supply of Machinery (Safety) Regulations 2008 and subsequent amendments (Schedule 2 - Part 2 - Annex II - natural or legal person authorised to compile the technical file: Xylem Service Italia S.r.l.)
- S.I. 2019/539 - The Ecodesign for Energy-Related Products and Energy Information (Amendment) (EU Exit) Regulations 2019 (water pump) if MEI marked, and technical standards:
 - EN 809:1998+A1:2009, EN 60335-1:2012+A11:2014+A13: 2017, EN 60335-2-41:2003+A1:2004 +A2:2010, EN 62233 :2008
 - EN 61800-9-1:2017, EN 61800-9-2:2017.

Montecchio Maggiore, 28/09/2021

Marco Ferretti
Chairman of the Board of Directors



rev.00

11.4 UKCA Declaration of Conformity (No 19)

1. EMC - Apparatus/Product model:
see rating plate
RoHS - Unique identification of the EEE:
HME, VME, SVE, SVIE.
2. Name and address of the manufacturer:
Xylem Service Italia S.r.l.
Via Vittorio Lombardi 14
36075 Montecchio Maggiore VI
Italy.
3. This declaration of conformity is issued under the sole responsibility of the manufacturer.
4. Object of the declaration:
Pump unit with integrated variable speed drive, with or without pressure transmitter and relative cable (see rating plate).
5. The object of the declaration described above is in conformity with the relevant legal acts:
 - S.I. 2016/1091 - The Electromagnetic Compatibility Regulations 2016 and subsequent amendments
 - S.I. 2012/3032 - The Restriction of the Use of Certain Hazardous Substances in Electrical and Electronic Equipment Regulations 2012 and subsequent amendments.
6. References to the relevant designated standards used or references to the other technical specifications, in relation to which conformity is declared:

- EN 60730-1:2011, EN 61800-3:2004+ A1:2012 (Category C2), EN 55014-1:2006 +A1:2009+A2:2011, EN 55014-2: 1997+ A1:2001+A2:2008, EN 61000-6-2:2005, EN 61000-6-3:2007+A1:2011
- EN IEC 63000:2018.

7. Approved body: -.

8. Additional information:

RoHS - Annex III of 2011/65/EU - Applications exempt from the restrictions: lead as a binding element in steel and copper alloys [6(a), 6(c)], in solders and in electrical/ electronic components [7(a), 7(c)-I].

Signed for and on behalf of: Xylem Service Italia S.r.l.

Montecchio Maggiore, 28/09/2021

Marco Ferretti
Chairman of the Board of Directors



rev.00

Lowara is a trademark of Xylem Inc. or one of its subsidiaries.

Xylem |'zīləm|

- 1) The tissue in plants that brings water upward from the roots;
- 2) A leading global water technology company.

We're a global team unified in a common purpose: creating innovative solutions to meet our world's water needs. Developing new technologies that will improve the way water is used, conserved, and re-used in the future is central to our work. We move, treat, analyze, and return water to the environment, and we help people use water efficiently, in their homes, buildings, factories and farms. In more than 150 countries, we have strong, long-standing relationships with customers who know us for our powerful combination of leading product brands and applications expertise, backed by a legacy of innovation.

For more information on how Xylem can help you, go to www.xylem.com



Xylem Service Italia S.r.l.
Via Vittorio Lombardi 14
36075 - Montecchio Maggiore (VI) - Italy
xylem.com/lowara

Lowara is a trademark of Xylem Inc. or one of its subsidiaries.
© 2018 Xylem, Inc. Cod.001080136EN rev.E ed.12/2021