



## Cordonel®

### Static flow meter for potable water DN 40...100

#### Applications

- Measurement for billing of potable water up to 50 °C
- Radio equipped flow meter for walk-by/drive-by readout applications
- Metering endpoint in radio based fixed Smart Water Networks
- Measurement of high flowrates, for example in pumped pipes for irrigation
- Measurement of low flow, for example in light load periods
- Leakage detection
- Flow meter for controlling industrial processes using a pulse output
- Flow meter supplying rich data for DMA analysis

#### FEATURES

- Uses ultrasonic technology with no moving parts or obstruction to the flow
- Maintenance free over its operational lifetime
- Large measuring range;  $Q_3/Q_1$  R1000
- Advanced UOD0 capability
- Meter with MID pattern approval according to annex MI001
- Meter conforms to OIML R49:2013 and ISO 4064:2017
- Constant accuracy over lifetime, no degradation as components age
- Installation in horizontal and vertical pipe orientations
- LCD for consumption, flow, temperature, pressure (optional) and status information
- Integrated radio communication and data logger
- Secure encrypted data transmission
- Meter can be submerged; meets protection class IPx8 acc. to 60529:2014
- NFC wireless interface for readout of the last volume reading
- 20-year average meter lifetime incl. battery under standard usage conditions
- Optional pulse output with programmable values and lengths

#### Available options

- Integrated pressure sensor
- Radio communication on alternative frequencies
- Pulse output with different pulse modes

#### Environmental conditions

- According to ISO 4064-1:2017
- Environmental class O acc. to OIML R49-1:2013
- Environmental temperature: -10 °C ... 70 °C
- Mechanical environmental conditions: class M2
- Electromagnetic environmental conditions: class E2

#### PERFORMANCE DATA

	Size	DN	40	50	65	80	100
$Q_3$	Max. Peak Flow	m <sup>3</sup> /h	78	90	125	200	310
$Q_4$	Overload Flowrate acc. to MID	m <sup>3</sup> /h	50	50	78.75	125	200
$Q_3$	Permanent Flowrate acc. to MID	m <sup>3</sup> /h	40	40	63	100	160
$Q_2$	Transitional Flowrate horizontal acc. to MID	m <sup>3</sup> /h	0.06	0.06	0.1	0.16	0.25
$Q_1$	Minimum Flowrate horizontal acc. to MID	m <sup>3</sup> /h	0.04	0.04	0.06	0.1	0.16
$Q_3/Q_1$	Max. Ratio		1000	1000	1000	1000	1000
	Starting Flow	m <sup>3</sup> /h	0.012	0.012	0.02	0.033	0.054

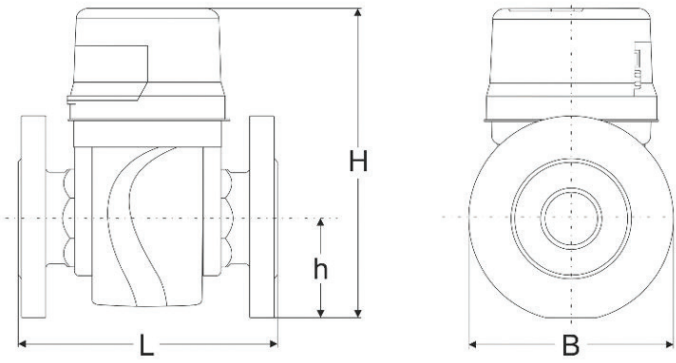

### MATERIALS

Body	Cast iron
Measuring Transducers	High grade polymer
Inner tube	High grade polymer; stainless steel
Battery	Lithium
Gaskets	EPDM
Other materials	Glass fiber reinforced polymer; stainless steel

### DIMENSIONS AND WEIGHTS

		DN	40	50	50	50	65	65	80
Nominal diameter		DN	40	50	50	50	65	65	80
Overall length	L	mm	220	200	270	300	200	300	200
Height	H	mm	238	238	238	238	258	258	297
Height to pipe axis	h	mm	69	73	73	73	85	85	95
Width	B	mm	166	166	166	166	186	186	201
Meter Weight		kg	7.8	9.0	9.7	10.1	11.0	12.8	13.4
Meter Weight with pressure sensor		kg	7.9	9.1	9.8	10.2	11.1	12.9	13.5

  

		DN	80	80	80	100	100	100
Nominal diameter		DN	80	80	80	100	100	100
Overall length	L	mm	225	300	350	250	350	360
Height	H	mm	297	297	296	315	315	315
Height to pipe axis	h	mm	95	95	95	105	105	105
Width	B	mm	201	201	201	220	220	220
Meter Weight		kg	13.9	15.9	16.8	17.9	20.4	20.7
Meter Weight with pressure sensor		kg	14.0	16.0	16.9	18.0	20.5	20.8

### Typical Headloss Curve

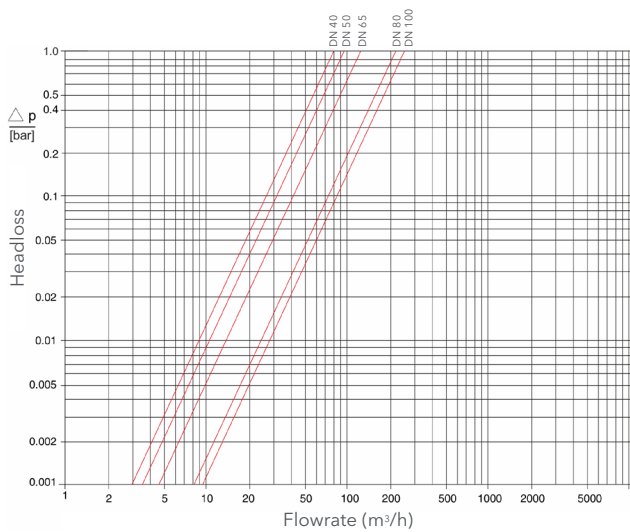

### Typical Error Curve

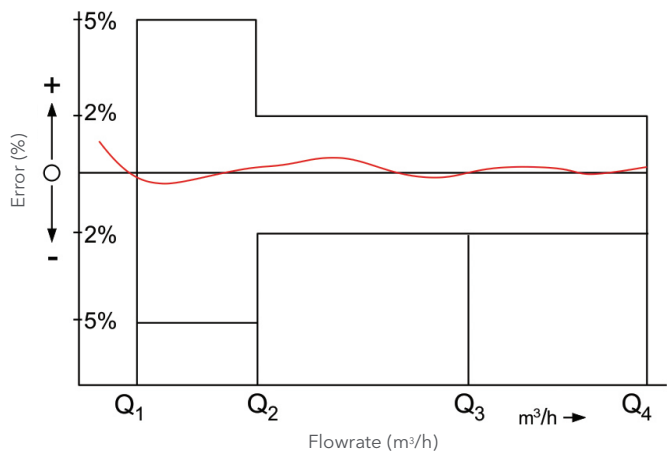

### Display



🚩 Alarm is triggered

🔋 Low battery level is reached

📶 Radio is activated (flashing)

TST System is set up in hydraulic testing mode

⊕⊖ Indicates positive or negative flow

	Smallest reading	Maximum reading
Working Mode DN 40 ... 100	0,001 m <sup>3</sup>	999.999,999 m <sup>3</sup>
Test Mode DN 40 ... 100	000,000001 m <sup>3</sup>	999,999999 m <sup>3</sup>

The bottom line displays flow, temperature or optionally pressure in an automatic loop.

### INSTALLATION

Pipe	horizontal vertical	
Meter head	upwards sideways	

- Unrestricted straight pipe upstream and downstream 0 x DN U0D0 acc. to OIML R 49-1:2013
- Meter display should not be installed with the display pointed downwards

### APPROVALS

<b>Metrology</b>	DE-19-MI001-PTB008
<b>Marking</b>	CE M-XX* 0102 (*year of conformity assessment)
<b>Potable Water</b>	KTW / DVGW WRAS ACS KIWA

### Order Example

	Type
	Size
	Maximum medium temperature
	Nominal pressure
<b>Cordonel, DN 50, T50, PN16</b>	
Drilling EN 1092 PN16	Drilling pattern
Length 200 mm	Body length
m <sup>3</sup>	Display unit
with MID conformity	Approval standard

# Cordonel®

## Static flow meter for potable water DN 40...100

**xylem**

Xylem.com | Sensus.com



**UK & Ireland Inquiries | Sensus UK Systems Ltd.** | 3 Lindenwood Crockford Lane, Chineham Business Park | Basingstoke RG24 8QY UK | +44 1256 372800 | [info.gb@xylem.com](mailto:info.gb@xylem.com)

**International Inquiries | Sensus GmbH Hannover** | Meineckestr. 10 | 30880 Laatzen | Germany | +49 5102 743177  
[info.int@xylem.com](mailto:info.int@xylem.com)

©2020 Sensus. All products purchased and services performed are subject to Sensus' terms of sale, available at [sensus.com](https://sensus.com). Sensus reserves the right to modify these terms and conditions in its own discretion. The Sensus logo and other Sensus products or services referenced are registered trademarks of Sensus.

This document is for informational purposes only, and SENSUS MAKES NO EXPRESS WARRANTIES IN THIS DOCUMENT. FURTHERMORE, THERE ARE NO IMPLIED WARRANTIES, INCLUDING WITHOUT LIMITATION, WARRANTIES AS TO FITNESS FOR A PARTICULAR PURPOSE AND MERCHANTABILITY. ANY USE OF THE PRODUCTS THAT IS NOT SPECIFICALLY PERMITTED HEREIN IS PROHIBITED.