

xylem 
watermark.

THE GREAT BOOK OF WATER

CELEBRATES WATER MONTH



Learn, color and enjoy!

◆ THE WATER CYCLE

Water is neither created nor destroyed, but transformed. The water we have today is the same water that the dinosaurs drank and that has traveled again and again between the layers of the earth...

This is called the Water Cycle.

HOW LONG IS THE WATER CYCLE?

Find out on **page 13** of The Big Book of Water.

◆ THE GODS OF WATER

The vision that the different indigenous peoples had about water is reflected in the stories that adults told to boys and girls and that survived in the tradition as legends...

DO YOU KNOW THE STORIES OF SOME OF THESE GODS?

Find out on **page 46-47** of The Great Book of Water.

◆ THE WATER FOOTPRINT

The water footprint is the total volume of water used from production to consumption of a product, plus the water required to treat the pollutants it produced.

WHAT TYPES OF WATER DOES THE WATER FOOTPRINT CONSIST OF?

Find out on **page 58-59** of The Great Book of Water.

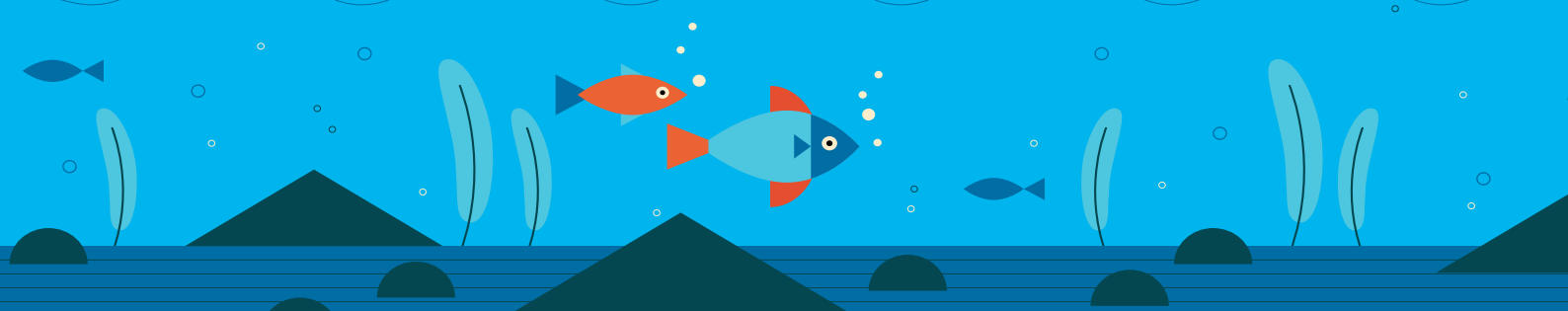

THE WATER CYCLE

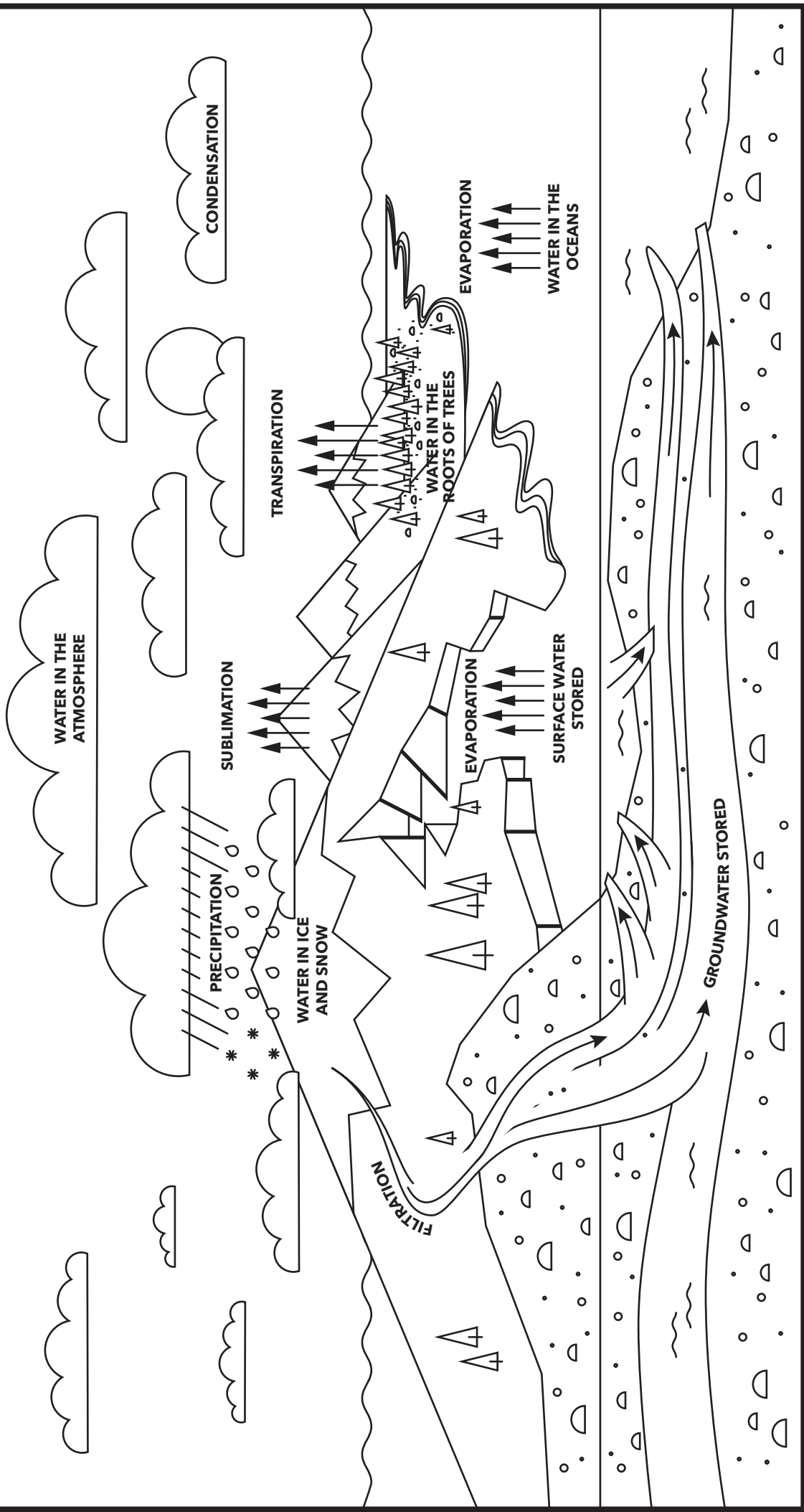

THE GODS OF WATER

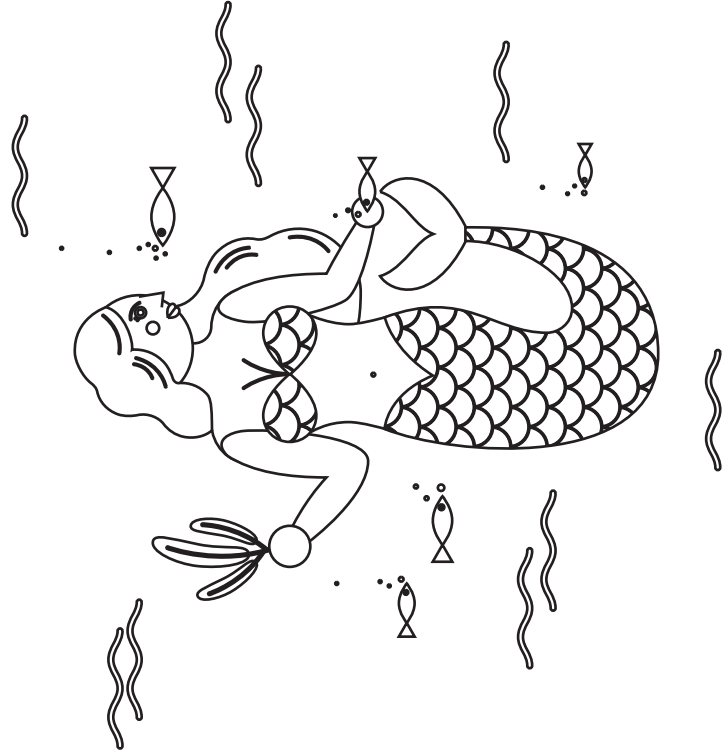

Achaneh

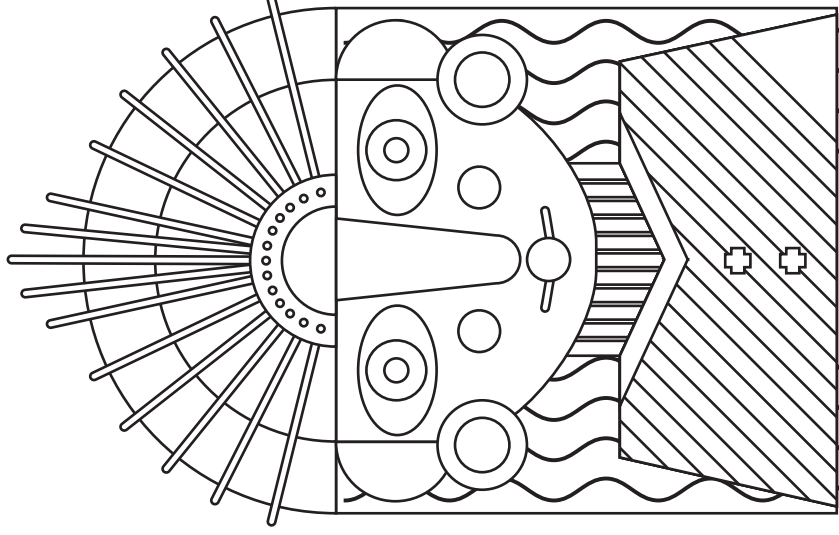

Chalchiuhtlicue

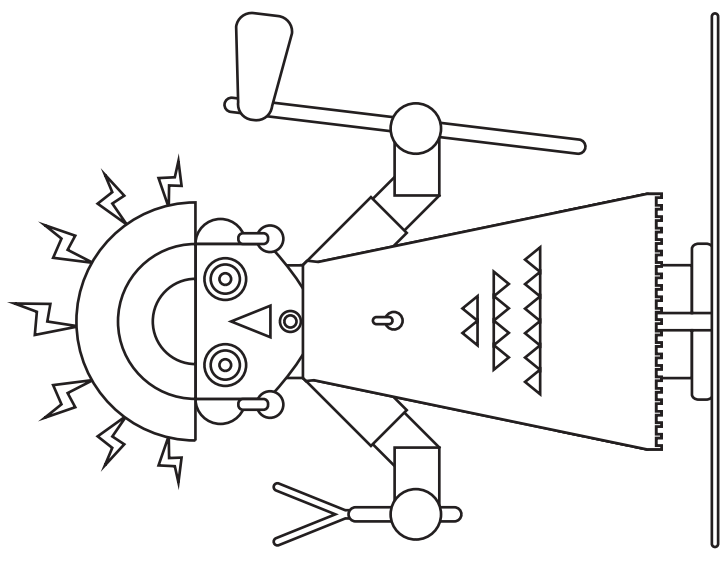

Illapa

THE WATER FOOTPRINT

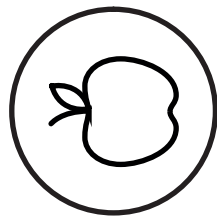

1 APPLE
70 LITERS

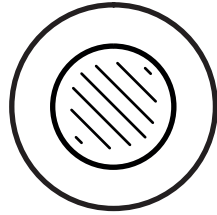

1 HAMBURGER
2400 LITERS

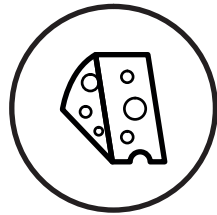

1 OF CHEESE
5000 LITERS

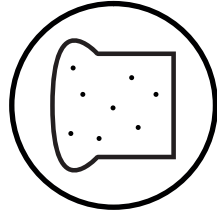

1 SLICE OF BREAD
40 LITERS

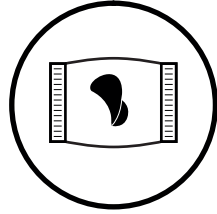

1 BAG OF CHIPS
185 LITERS



Scan the QR to access the

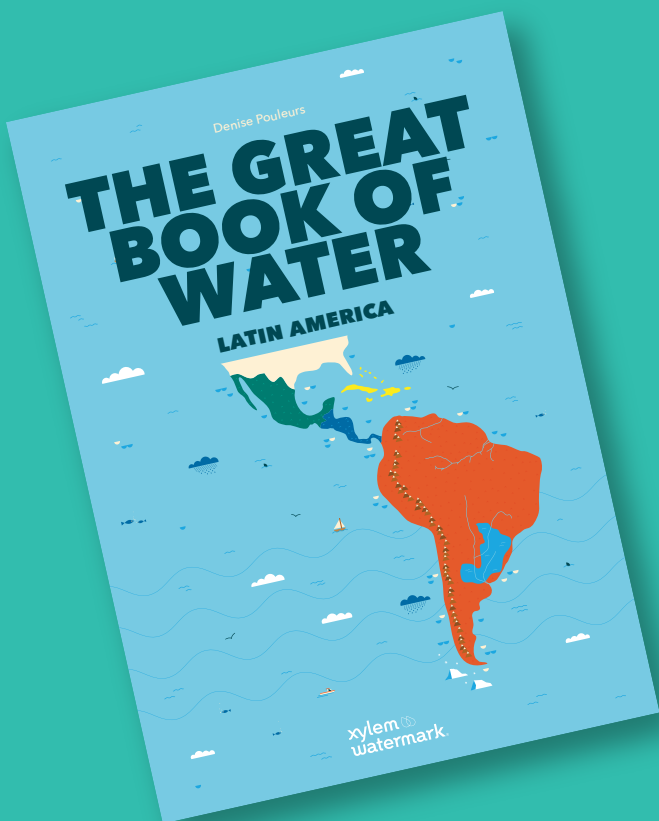

xylem 
watermark®